

A
B
C

TM

SECTION

TRANSAXLE & TRANSMISSION

TM

CONTENTS

CVT: RE0F10H		E
PRECAUTION	6	
PRECAUTIONS	6	
Precaution for Supplemental Restraint System (SRS) "AIR BAG" and "SEAT BELT PRE-TENSIONER"	6	
Precaution for Procedure without Cowl Top Cover.....	6	
Precaution for TCM and Transaxle Assembly Replacement	6	
General Precautions	7	
On Board Diagnosis (OBD) System of CVT and Engine	8	
Removal and Installation Procedure for CVT Unit Connector	8	
PREPARATION	10	
PREPARATION	10	
Special Service Tools	10	
Commercial Service Tools	10	
SYSTEM DESCRIPTION	12	
COMPONENT PARTS	12	
CVT CONTROL SYSTEM	12	
CVT CONTROL SYSTEM : Component Parts Location	12	
CVT CONTROL SYSTEM : TCM	14	
CVT CONTROL SYSTEM : Transmission Range Switch	14	
CVT CONTROL SYSTEM : Primary Speed Sensor	14	
CVT CONTROL SYSTEM : Output Speed Sensor... ..	14	
CVT CONTROL SYSTEM : Input Speed Sensor	15	
CVT CONTROL SYSTEM : CVT Fluid Temperature Sensor	15	
CVT CONTROL SYSTEM : Primary Pressure Sensor	16	
CVT CONTROL SYSTEM : Secondary Pressure Sensor	16	
CVT CONTROL SYSTEM : Primary Pressure Solenoid Valve	17	
CVT CONTROL SYSTEM : Secondary Pressure Solenoid Valve	17	
CVT CONTROL SYSTEM : Select Solenoid Valve	17	
CVT CONTROL SYSTEM : Torque Converter Clutch Solenoid Valve	18	
CVT CONTROL SYSTEM : Line Pressure Solenoid Valve	18	
CVT CONTROL SYSTEM : Manual Mode Switch... ..	18	
CVT CONTROL SYSTEM : Paddle Shifter	19	
CVT CONTROL SYSTEM : Shift Position Indicator	19	
SHIFT LOCK SYSTEM	19	
SHIFT LOCK SYSTEM : Component Parts Location	19	
STRUCTURE AND OPERATION	20	
TRANSAXLE	20	
TRANSAXLE : Cross-Sectional View	20	
TRANSAXLE : Operation Status	21	
TRANSAXLE : Transaxle Mechanism	21	
TRANSAXLE : Oil Pressure System	23	
TRANSAXLE : Component Description	24	
FLUID COOLER & FLUID WARMER SYSTEM	24	
FLUID COOLER & FLUID WARMER SYSTEM : System Description	25	
SHIFT LOCK SYSTEM	25	
SHIFT LOCK SYSTEM : System Description	25	
SYSTEM	27	
CVT CONTROL SYSTEM	27	
CVT CONTROL SYSTEM : System Description	27	
CVT CONTROL SYSTEM : Fail-safe	28	
CVT CONTROL SYSTEM : Protection Control	31	

LINE PRESSURE CONTROL	32	ADDITIONAL SERVICE WHEN REPLACING TCM	76
LINE PRESSURE CONTROL : System Description	32	Description	76
SHIFT CONTROL	33	Work Procedure	76
SHIFT CONTROL : System Description	33	ADDITIONAL SERVICE WHEN REPLACING TRANSAXLE ASSEMBLY	77
SELECT CONTROL	36	Description	77
SELECT CONTROL : System Description	36	Work Procedure	77
LOCK-UP CONTROL	36	ADDITIONAL SERVICE WHEN REPLACING TCM AND TRANSAXLE ASSEMBLY	79
LOCK-UP CONTROL : System Description	36	Description	79
INFORMATION DISPLAY (COMBINATION METER)	37	Work Procedure	79
INFORMATION DISPLAY (COMBINATION METER) : Shift Position Indicator	37	CVT FLUID	81
WARNING/INDICATOR/CHIME LIST	38	Replacement	81
WARNING/INDICATOR/CHIME LIST : Warning Lamp/Indicator Lamp	38	Adjustment	82
WARNING/INDICATOR/CHIME LIST : Warning/Indicator (On Information Display)	38	STALL TEST	84
ON BOARD DIAGNOSTIC (OBD) SYSTEM	39	Work Procedure	84
Description	39	CVT POSITION	85
Function of OBD	39	Inspection	85
DIAGNOSIS SYSTEM (TCM)	40	Adjustment	85
DIAGNOSIS DESCRIPTION	40	HOW TO ERASE PERMANENT DTC	86
DIAGNOSIS DESCRIPTION : 1 Trip Detection Diagnosis and 2 Trip Detection Diagnosis	40	Description	86
DIAGNOSIS DESCRIPTION : DTC and DTC of 1st Trip	40	DTC/CIRCUIT DIAGNOSIS	87
DIAGNOSIS DESCRIPTION : Malfunction Indicator Lamp (MIL)	40	U0073 COMMUNICATION BUS A OFF	87
DIAGNOSIS DESCRIPTION : Counter System	40	DTC Description	87
CONSULT Function	42	Diagnosis Procedure	87
ECU DIAGNOSIS INFORMATION	47	U0100 LOST COMMUNICATION (ECM A)	88
TCM	47	DTC Description	88
Reference Value	47	Diagnosis Procedure	88
Fail-safe	53	U0140 LOST COMMUNICATION (BCM)	89
Protection Control	56	DTC Description	89
DTC Inspection Priority Chart	57	Diagnosis Procedure	89
DTC Index	58	U0141 LOST COMMUNICATION (BCM A)	90
WIRING DIAGRAM	60	DTC Description	90
CVT CONTROL SYSTEM	60	Diagnosis Procedure	90
Wiring diagram	60	U0155 LOST COMMUNICATION (IPC)	91
CVT SHIFT LOCK SYSTEM	70	DTC Description	91
Wiring Diagram	70	Diagnosis Procedure	91
BASIC INSPECTION	73	U0300 CAN COMMUNICATION DATA	92
DIAGNOSIS AND REPAIR WORK FLOW	73	DTC Description	92
Work Flow	73	Diagnosis Procedure	92
Diagnostic Work Sheet	74	U1000 CAN COMM CIRCUIT	94
		DTC Description	94
		Diagnosis Procedure	94
		U1117 LOST COMMUNICATION (ABS)	95
		DTC Description	95
		Diagnosis Procedure	95

P062F EEPROM	96	DTC Description	133	
DTC Description	96	Diagnosis Procedure	133	A
Diagnosis Procedure	96			
P0705 TRANSMISSION RANGE SENSOR A	98	P0826 UP AND DOWN SHIFT SW	135	
DTC Description	98	DTC Description	135	B
Diagnosis Procedure	98	Diagnosis Procedure	136	
Component Inspection	101	Component Inspection (Manual Mode Switch)	139	
		Component Inspection (Paddle Shifter)	140	C
P0706 TRANSMISSION RANGE SENSOR A	103	P0841 TRANSMISSION FLUID PRESSURE		
DTC Description	103	SEN/SW A	141	
Diagnosis Procedure	103	DTC Description	141	TM
Component Inspection	105	Diagnosis Procedure	142	
P0711 TRANSMISSION FLUID TEMPERA-		P0847 TRANSMISSION FLUID PRESSURE		
TURE SENSOR A	106	SEN/SW B	143	E
DTC Description	106	DTC Description	143	
Diagnosis Procedure	109	Diagnosis Procedure	143	
P0712 TRANSMISSION FLUID TEMPERA-		P0848 TRANSMISSION FLUID PRESSURE		F
TURE SENSOR A	111	SEN/SW B	145	
DTC Description	111	DTC Description	145	G
Diagnosis Procedure	111	Diagnosis Procedure	146	
P0713 TRANSMISSION FLUID TEMPERA-		P084C TRANSMISSION FLUID PRESSURE		
TURE SENSOR A	113	SEN/SW H	147	H
DTC Description	113	DTC Description	147	
Diagnosis Procedure	113	Diagnosis Procedure	147	
P0715 INPUT SPEED SENSOR A	115	P084D TRANSMISSION FLUID PRESSURE		I
DTC Description	115	SEN/SW H	149	
Diagnosis Procedure	116	DTC Description	149	J
		Diagnosis Procedure	149	
P0717 INPUT SPEED SENSOR A	118	P0863 TCM COMMUNICATION	151	
DTC Description	118	DTC Description	151	K
Diagnosis Procedure	119	Diagnosis Procedure	151	
P0740 TORQUE CONVERTER	121	P0890 TCM	152	
DTC Description	121	DTC Description	152	L
Diagnosis Procedure	122	Diagnosis Procedure	152	
P0743 TORQUE CONVERTER	123	P0962 PRESSURE CONTROL SOLENOID A	154	
DTC Description	123	DTC Description	154	M
Diagnosis Procedure	124	Diagnosis Procedure	154	
P0744 TORQUE CONVERTER	125	P0963 PRESSURE CONTROL SOLENOID A	156	
DTC Description	125	DTC Description	156	N
Diagnosis Procedure	126	Diagnosis Procedure	156	
P0746 PRESSURE CONTROL SOLENOID A	127	P0965 PRESSURE CONTROL SOLENOID B	158	
DTC Description	127	DTC Description	158	O
Diagnosis Procedure	128	Diagnosis Procedure	159	
P0776 PRESSURE CONTROL SOLENOID B	129	P0966 PRESSURE CONTROL SOLENOID B	160	
DTC Description	129	DTC Description	160	P
Diagnosis Procedure	130	Diagnosis Procedure	160	
P0778 PRESSURE CONTROL SOLENOID B	131	P0967 PRESSURE CONTROL SOLENOID B	162	
DTC Description	131	DTC Description	162	
Diagnosis Procedure	131	Diagnosis Procedure	162	
P0779 PRESSURE CONTROL SOLENOID B	133			

P2765 INPUT SPEED SENSOR B	164	AIR BREATHER HOSE	193
DTC Description	164	Exploded View	193
Diagnosis Procedure	165	Removal and Installation	193
P2813 SELECT SOLENOID	168	CONTROL VALVE	195
DTC Description	168	Exploded View	195
Diagnosis Procedure	169	Removal and Installation	195
P2814 SELECT SOLENOID	170	Inspection and Adjustment	200
DTC Description	170	INPUT SPEED SENSOR	201
Diagnosis Procedure	170	Exploded View	201
P2815 SELECT SOLENOID	172	Removal and Installation	201
DTC Description	172	Inspection and Adjustment	201
Diagnosis Procedure	172	PRIMARY SPEED SENSOR	202
MAIN POWER SUPPLY AND GROUND CIR-		Exploded View	202
CUIT	174	Removal and Installation	202
Diagnosis Procedure	174	Inspection and Adjustment	202
SHIFT POSITION INDICATOR CIRCUIT	176	OUTPUT SPEED SENSOR	203
Component Parts Function Inspection	176	Exploded View	203
Diagnosis Procedure	176	Removal and Installation	203
SHIFT LOCK SYSTEM	177	Inspection and Adjustment	203
Component Function Check	177	DIFFERENTIAL SIDE OIL SEAL	204
Diagnosis Procedure	177	Exploded View	204
Component Inspection (Shift Lock Solenoid)	178	Removal and Installation	204
Component Inspection (Park Position Switch)	178	Inspection and Adjustment	205
Component Inspection (Stop Lamp Switch)	179	CVT OIL WARMER SYSTEM	206
SYMPTOM DIAGNOSIS	180	WATER HOSE	206
CVT CONTROL SYSTEM	180	WATER HOSE : Exploded View	206
Symptom Table	180	WATER HOSE : Removal and Installation	206
PERIODIC MAINTENANCE	184	WATER HOSE : Inspection	208
CVT FLUID	184	CVT FLUID COOLER HOSE	208
Inspection	184	CVT FLUID COOLER HOSE : Exploded View	208
REMOVAL AND INSTALLATION	185	CVT FLUID COOLER HOSE : Removal and In-	208
CVT SHIFT SELECTOR	185	stallation	208
Exploded View	185	CVT FLUID COOLER HOSE : Inspection	210
Removal and Installation	185	CVT OIL WARMER	210
Inspection	186	CVT OIL WARMER : Exploded View	210
CONTROL CABLE	187	CVT OIL WARMER : Removal and Installation ...	210
Exploded View	187	CVT OIL WARMER : Inspection	210
Removal and Installation	187	PLUG	211
Inspection and Adjustment	188	Description	211
PADDLE SHIFTER	189	Exploded View	211
Exploded View	189	Removal and Installation	211
Removal and Installation	189	Inspection and Adjustment	211
TCM	191	UNIT REMOVAL AND INSTALLATION ...	212
Exploded View	191	TRANSAXLE ASSEMBLY	212
Removal and Installation	191	Exploded View	212
Adjustment	192	Removal and Installation	212
		Inspection and Adjustment	214
		UNIT DISASSEMBLY AND ASSEMBLY ..	215

TORQUE CONVERTER AND CONVERTER

HOUSING OIL SEAL	215
Exploded View	215
Disassembly	215
Assembly	215
Inspection	216

SERVICE DATA AND SPECIFICATIONS

(SDS)	218
--------------------	------------

SERVICE DATA AND SPECIFICATIONS

(SDS)	218
General Specification	218
Shift Characteristics	218
Stall Speed	218
Torque Converter	218
Heater Thermostat	218

A
B
C

TM

E
F
G
H
I
J
K
L
M
N
O
P

PRECAUTION

PRECAUTIONS

Precaution for Supplemental Restraint System (SRS) "AIR BAG" and "SEAT BELT PRE-TENSIONER"

INFOID:000000011972855

The Supplemental Restraint System such as "AIR BAG" and "SEAT BELT PRE-TENSIONER", used along with a front seat belt, helps to reduce the risk or severity of injury to the driver and front passenger for certain types of collision. Information necessary to service the system safely is included in the SR and SB section of this Service Manual.

WARNING:

- To avoid rendering the SRS inoperative, which could increase the risk of personal injury or death in the event of a collision which would result in air bag inflation, all maintenance must be performed by an authorized NISSAN/INFINITI dealer.
- Improper maintenance, including incorrect removal and installation of the SRS, can lead to personal injury caused by unintentional activation of the system. For removal of Spiral Cable and Air Bag Module, see the SR section.
- Do not use electrical test equipment on any circuit related to the SRS unless instructed to in this Service Manual. SRS wiring harnesses can be identified by yellow and/or orange harnesses or harness connectors.

PRECAUTIONS WHEN USING POWER TOOLS (AIR OR ELECTRIC) AND HAMMERS

WARNING:

- When working near the Airbag Diagnosis Sensor Unit or other Airbag System sensors with the Ignition ON or engine running, DO NOT use air or electric power tools or strike near the sensor(s) with a hammer. Heavy vibration could activate the sensor(s) and deploy the air bag(s), possibly causing serious injury.
- When using air or electric power tools or hammers, always switch the Ignition OFF, disconnect the battery and wait at least three minutes before performing any service.

Precaution for Procedure without Cowl Top Cover

INFOID:000000011972856

When performing the procedure after removing cowl top cover, cover the lower end of windshield with urethane, etc to prevent damage to windshield.

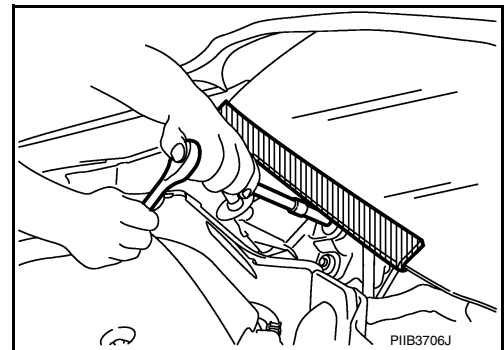

Precaution for TCM and Transaxle Assembly Replacement

INFOID:000000011972857

CAUTION:

- To replace TCM, refer to [TM-76, "Description"](#).
- To replace transaxle assembly, refer to [TM-77, "Description"](#).

PRECAUTIONS

< PRECAUTION >

[CVT: RE0F10H]

INFOID:000000011972858

General Precautions

- Turn ignition switch OFF and disconnect the battery cable from the negative terminal before connecting or disconnecting the CVT assembly harness connector. Because battery voltage is applied to TCM even if ignition switch is turned OFF.

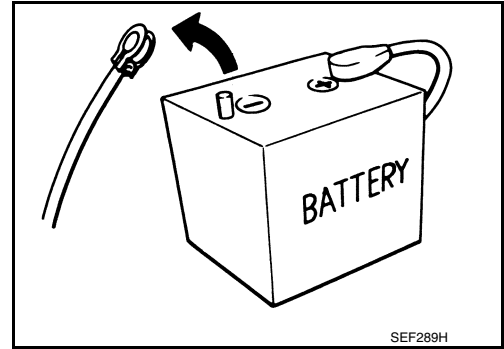

- When connecting or disconnecting pin connectors into or from TCM, do not damage pin terminals (bend or break). Check that there are not any bends or breaks on TCM pin terminal, when connecting pin connectors.

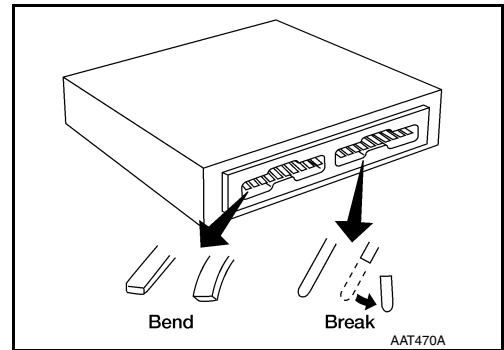

- Perform TCM input/output signal inspection and check whether TCM functions normally or not before replacing TCM. Refer to [TM-47, "Reference Value"](#).

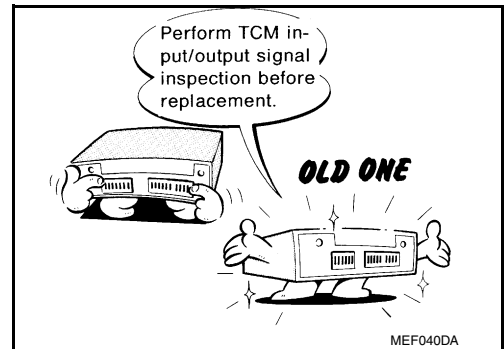

- Perform "DTC (Diagnostic Trouble Code) CONFIRMATION PROCEDURE". If the repair is completed DTC should not be displayed in the "DTC CONFIRMATION PROCEDURE".

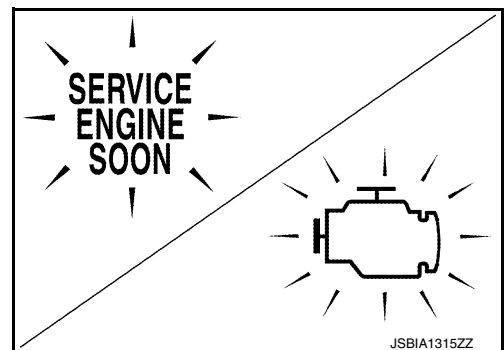

- Always use the specified brand of CVT fluid. Refer to [MA-16, "FOR USA AND CANADA : Fluids and Lubricants"](#) (for USA and CANADA) or [MA-17, "FOR MEXICO : Fluids and Lubricants"](#) (for MEXICO).
- Use lint-free paper not cloth rags during work.
- Dispose of the waste oil using the methods prescribed by law, ordinance, etc. after replacing the CVT fluid.

A
B
C
TM
E
F
G
H
I
J
K
L
M
N
O
P

PRECAUTIONS

< PRECAUTION >

[CVT: RE0F10H]

On Board Diagnosis (OBD) System of CVT and Engine

INFOID:000000011972859

The TCM and ECM have an on board diagnostic system. It will light up the malfunction indicator lamp (MIL) to warn the driver of a malfunction causing emission deterioration.

CAUTION:

- Be sure to turn the ignition switch OFF and disconnect the battery cable from the negative terminal before any repair or inspection work. The open/short circuit of related switches, sensors, solenoid valves, etc. will cause the MIL to light up.
- Be sure to connect and lock the connectors securely after work. A loose (unlocked) connector will cause the MIL to light up due to an open circuit. (Be sure the connector is free from water, grease, dirt, bent terminals, etc.)
- Be sure to route and secure the harnesses properly after work. Interference of the harness with a bracket, etc. may cause the MIL to light up due to a short circuit.
- Be sure to connect rubber tubes properly after work. A misconnected or disconnected rubber tube may cause the MIL to light up due to a malfunction of the EGR system or fuel injection system, etc.
- Be sure to erase the unnecessary malfunction information (repairs completed) from the TCM and ECM before returning the vehicle to the customer.

Removal and Installation Procedure for CVT Unit Connector

INFOID:000000011972860

REMOVAL

- Rotate bayonet ring ① counterclockwise. Pull out CVT unit harness connector ② upward and remove it.

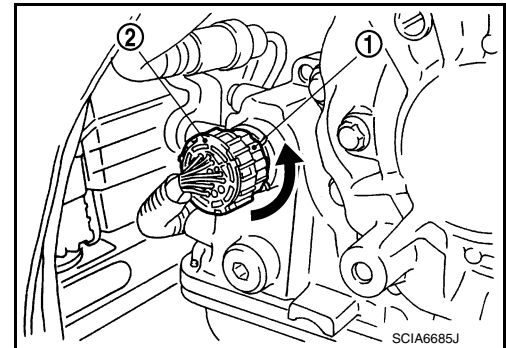

INSTALLATION

1. Align marking (A) on CVT unit harness connector terminal with marking (B) on bayonet ring. Insert CVT unit harness connector.
2. Rotate bayonet ring clockwise.

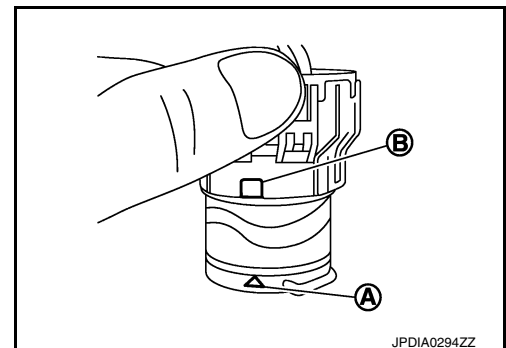

3. Rotate bayonet ring clockwise until marking (A) on CVT unit harness connector terminal body is aligned with the slit (B) on bayonet ring as shown in the figure (correctly fitting condition).

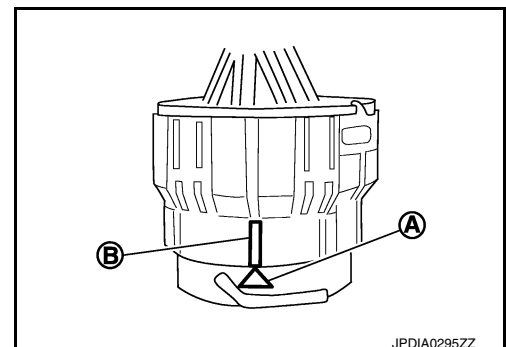

CAUTION:

PRECAUTIONS

< PRECAUTION >

[CVT: RE0F10H]

- Securely align marking (A) on CVT unit harness connector terminal body with bayonet ring slit (B). Then, be careful not to make a half fit condition as shown in the figure.
- Never mistake the slit of bayonet ring for other dent portion.

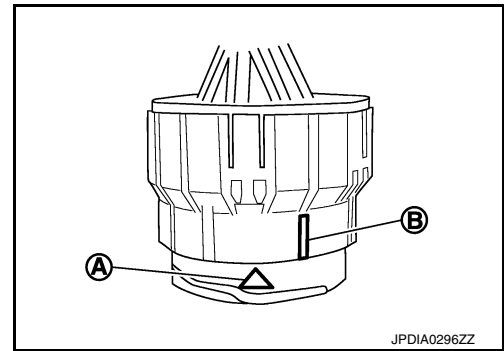

A
B
C

TM

E

F

G

H

I

J

K

L

M

N

O

P

PREPARATION

< PREPARATION >

[CVT: RE0F10H]

PREPARATION

PREPARATION

Special Service Tools

INFOID:0000000011972861

The actual shape of the tools may differ from those illustrated here.

Tool number (TechMate No.) Tool name	Description
1. KV311039S0 Charging pipe set 2. KV31103920* O-ring	CVT fluid changing and adjustment
KV38107900 Protector a: 32 mm dia.	Installing drive shaft
KV31103700 Drift a: 53 mm (2.09 in) dia. b: 57 mm (2.24 in) dia. c: 70 mm (2.76 in) dia. d: 8 mm (0.31 in) dia.	Differential side oil seal (Transaxle case side)

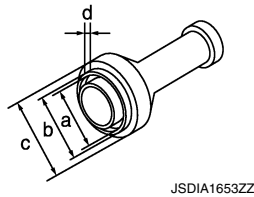
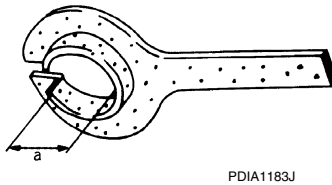
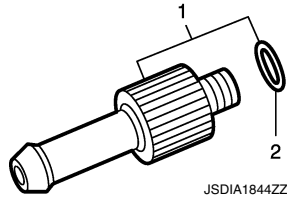

*: The O-ring as a unit part is set as a SST.

Commercial Service Tools

INFOID:0000000011972862

Tool number Tool name	Description
Power tool	Loosening nuts, screws and bolts

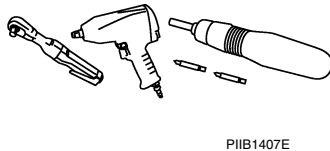

PREPARATION

< PREPARATION >

[CVT: RE0F10H]

Tool number Tool name	Description
<p>Drift a: 47 mm (1.85 in) dia. b: 51 mm (2.01 in) dia. c: 70 mm (2.76 in) dia. d: 8 mm (0.31 in) dia.</p>	<p>Differential side oil seal (Converter housing side)</p>
<p>Drift a: 65 mm (2.56 in) dia. b: 60 mm (2.36 in) dia.</p>	<p>Installing converter housing oil seal</p>

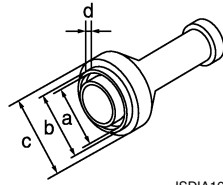

JSDIA1653ZZ

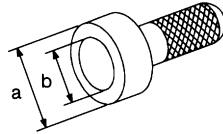

NT115

A
B
C
TM
E
F
G
H
I
J
K
L
M
N
O
P

COMPONENT PARTS

< SYSTEM DESCRIPTION >

[CVT: RE0F10H]

SYSTEM DESCRIPTION

COMPONENT PARTS

CVT CONTROL SYSTEM

CVT CONTROL SYSTEM : Component Parts Location

INFOID:000000011972863

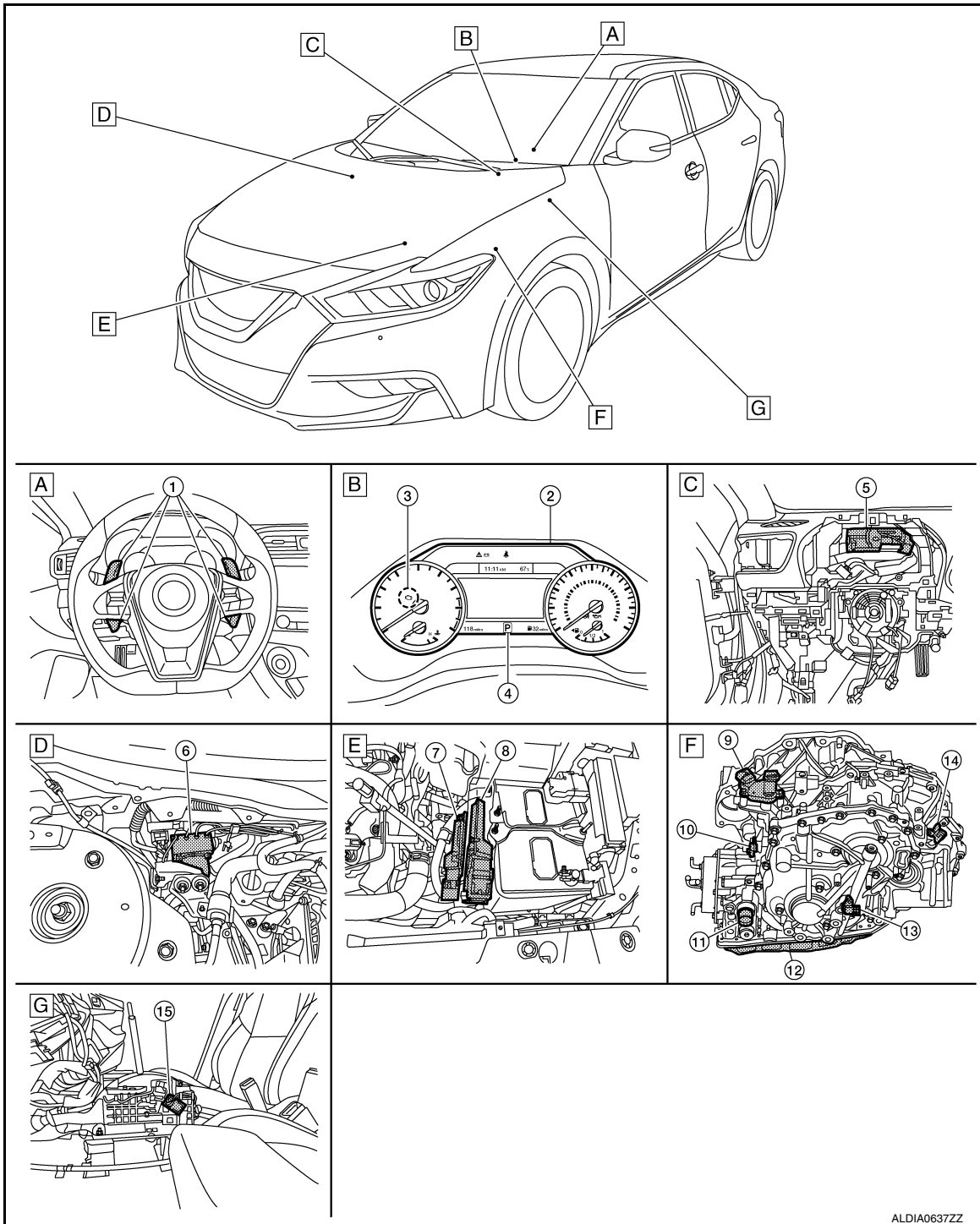

ALDIA0637ZZ

A Behind of steering wheel

B Combination meter

C Behind of combination meter

D Engine room RH

E Engine room LH

F Transaxle assembly

G CVT shift selector assembly

COMPONENT PARTS

< SYSTEM DESCRIPTION >

[CVT: RE0F10H]

No.	Component	Function
①	Paddle shifter*1	TM-19. "CVT CONTROL SYSTEM : Paddle Shifter"
②	Combination meter	<p>The TCM receives the following signal via CAN communications from the combination meter for judging the driving request from the driver.</p> <ul style="list-style-type: none"> • Manual mode signal • Non-manual mode signal • Manual mode shift up signal • Manual mode shift down signal • Paddle shifter shift up signal*1 • Paddle shifter shift down signal*1 • Vehicle speed signal • Sport mode switch signal <p>The TCM transmits the following signal via CAN communications to the combination meter.</p> <ul style="list-style-type: none"> • Shift position indicator signal • Sport mode indicator signal <p>Refer to MWI-5. "METER SYSTEM : Component Parts Location" for detailed installation location.</p>
③	Malfunction indicator lamp (MIL)	TM-40. "DIAGNOSIS DESCRIPTION : Malfunction Indicator Lamp (MIL)"
④	Shift position indicator	TM-19. "CVT CONTROL SYSTEM : Shift Position Indicator"
⑤	BCM	Refer to BCS-5. "BODY CONTROL SYSTEM : Component Parts Location" for detailed installation location.
⑥	ABS actuator and electric unit (control unit)	<p>The TCM receives the following signal via CAN communications from the ABS actuator and electric unit (control unit).</p> <ul style="list-style-type: none"> • ABS operation signal • TCS operation signal • VDC operation signal • ABS malfunction signal <p>Refer to BRC-10. "Component Parts Location" (without ICC) or BRC-178. "Component Parts Location" (with ICC) for detailed installation location.</p>
⑦	TCM	TM-14. "CVT CONTROL SYSTEM : TCM"
⑧	ECM	<ul style="list-style-type: none"> • For purposes including improving the feeling when shifting speeds and preventing drops in engine speed, control signals are exchanged between the ECM and TCM, and real-time cooperative control is performed according to the vehicle driving conditions. (Engine and CVT integrated control) - Engine and CVT integrated control signal <p>NOTE: General term for the communication (torque-down permission, torque-down request, etc.) exchanged between the ECM and TCM.</p> <ul style="list-style-type: none"> • The TCM receives the following signal via CAN communications from the ECM. - Engine speed signal - Accelerator pedal position signal - Closed throttle position signal • The TCM transmits the following signal via CAN communications to the ECM. - Malfunctioning indicator lamp signal <p>Refer to EC-15. "ENGINE CONTROL SYSTEM : Component Parts Location" for detailed installation location.</p>
⑨	Transmission range switch	TM-14. "CVT CONTROL SYSTEM : Transmission Range Switch"
⑩	Input speed sensor	TM-15. "CVT CONTROL SYSTEM : Input Speed Sensor"
⑪	CVT unit connector	—

A
B
C
TM
E
F
G
H
I
J
K
L
M
N
O
P

COMPONENT PARTS

< SYSTEM DESCRIPTION >

[CVT: RE0F10H]

No.	Component	Function
⑫	Control valve	
	CVT fluid temperature sensor* ²	TM-15, "CVT CONTROL SYSTEM : CVT Fluid Temperature Sensor"
	Primary pressure sensor* ²	TM-16, "CVT CONTROL SYSTEM : Primary Pressure Sensor"
	Secondary pressure sensor* ²	TM-16, "CVT CONTROL SYSTEM : Secondary Pressure Sensor"
	Primary pressure solenoid valve* ²	TM-17, "CVT CONTROL SYSTEM : Primary Pressure Solenoid Valve"
	Secondary pressure solenoid valve* ²	TM-17, "CVT CONTROL SYSTEM : Secondary Pressure Solenoid Valve"
	Select solenoid valve* ²	TM-17, "CVT CONTROL SYSTEM : Select Solenoid Valve"
	Torque converter clutch solenoid valve* ²	TM-18, "CVT CONTROL SYSTEM : Torque Converter Clutch Solenoid Valve"
	Line pressure solenoid valve* ²	TM-18, "CVT CONTROL SYSTEM : Line Pressure Solenoid Valve"
⑬	Primary speed sensor	TM-14, "CVT CONTROL SYSTEM : Primary Speed Sensor"
⑭	Output speed sensor	TM-14, "CVT CONTROL SYSTEM : Output Speed Sensor"
⑮	Manual mode switch	TM-18, "CVT CONTROL SYSTEM : Manual Mode Switch"

*1: Models with paddle shifter

*2: These components are included in control valve assembly.

CVT CONTROL SYSTEM : TCM

INFOID:000000011972864

- The vehicle driving status is judged based on the signals from the sensors, switches, and other control units, and the optimal transaxle control is performed.
- For TCM control items, refer to [TM-27, "CVT CONTROL SYSTEM : System Description"](#).

CVT CONTROL SYSTEM : Transmission Range Switch

INFOID:000000011972865

- The transmission range switch is installed to upper part of transaxle case.
- The transmission range switch detects the selector lever position.

CVT CONTROL SYSTEM : Primary Speed Sensor

INFOID:000000011972866

- The primary speed sensor is installed to side cover of transaxle.
- The primary speed sensor detects primary pulley speed.
- The primary speed sensor generates an ON-OFF pulse signal according to the rotating body speed. TCM judges the rotating body speed from the pulse signal.

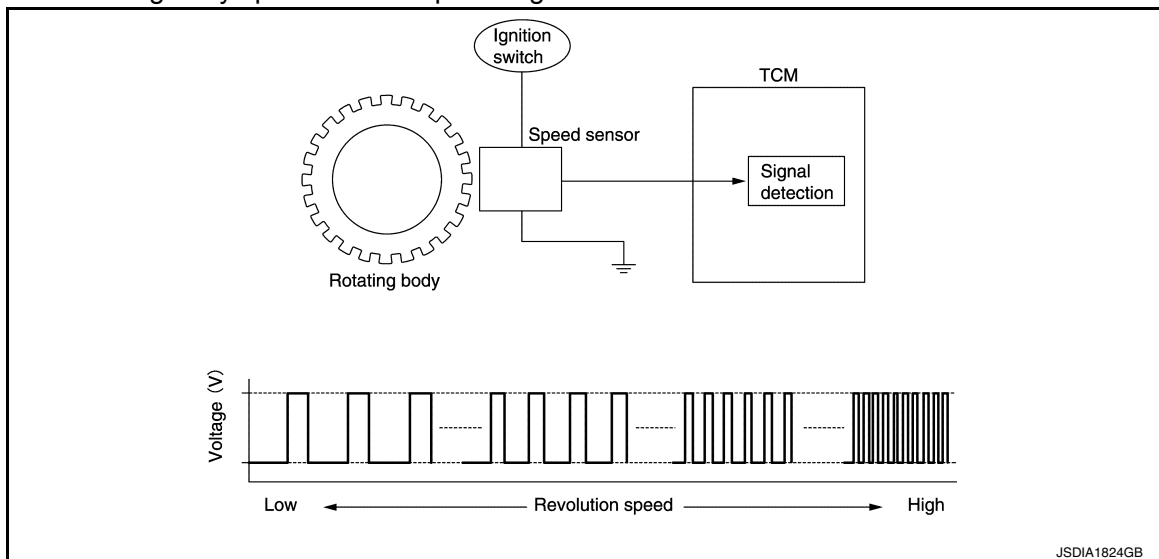

CVT CONTROL SYSTEM : Output Speed Sensor

INFOID:000000011972867

- The output speed sensor is installed to back side of transaxle.
- The output speed sensor detects final gear speed.

COMPONENT PARTS

< SYSTEM DESCRIPTION >

[CVT: RE0F10H]

- The output speed sensor generates the ON-OFF pulse (short waveform) in proportion to the rotating body speed which is “The higher the rotating body speed is, the faster the change cycle is”. The TCM judges the rotating speed from the changing cycle of this pulse signal.

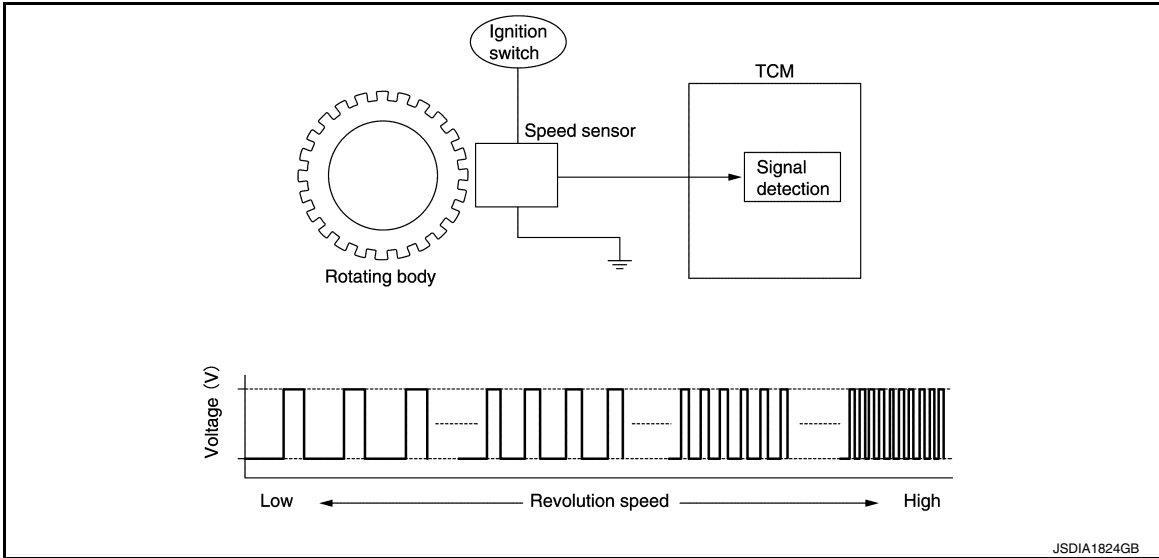

CVT CONTROL SYSTEM : Input Speed Sensor

INFOID:000000011972868

- The input speed sensor is installed to the front side of transaxle case.
- The input speed sensor detects input shaft speed.
- The input speed sensor generates an ON-OFF pulse signal according to the rotating body speed. TCM judges the rotating body speed from the pulse signal.

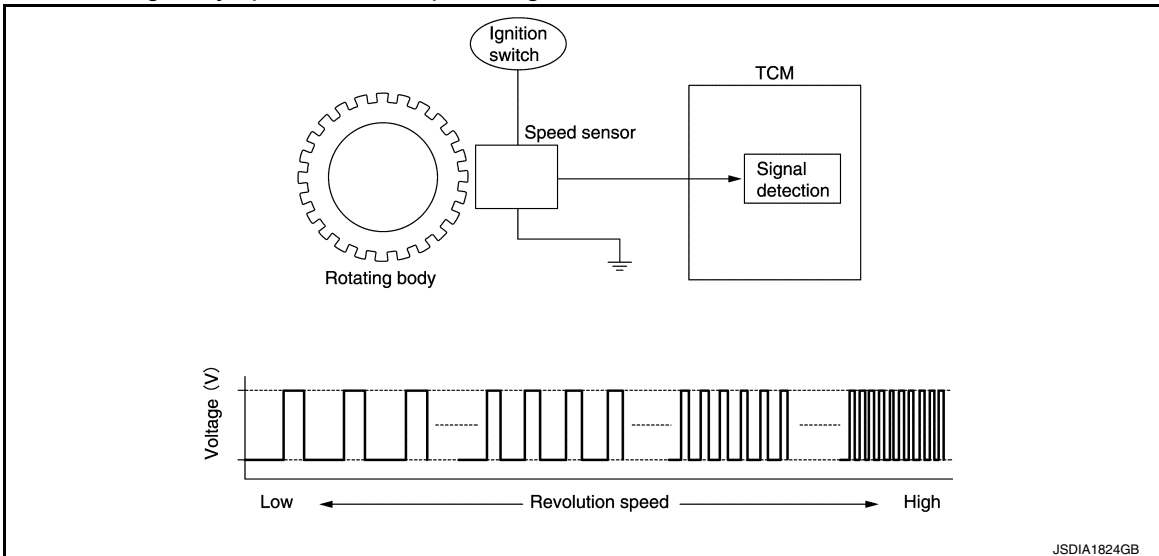

CVT CONTROL SYSTEM : CVT Fluid Temperature Sensor

INFOID:000000011972869

- The CVT fluid temperature sensor is installed to control valve.
- The CVT fluid temperature sensor detects CVT fluid temperature in oil pan.

A
B
C
TM
E
F
G
H
I
J
K
L
M
N
O
P

COMPONENT PARTS

< SYSTEM DESCRIPTION >

[CVT: RE0F10H]

- The fluid temperature sensor uses a thermistor, and changes the signal voltage by converting changes in the CVT fluid temperature to a resistance value. TCM evaluates the CVT fluid temperature from the signal voltage value.

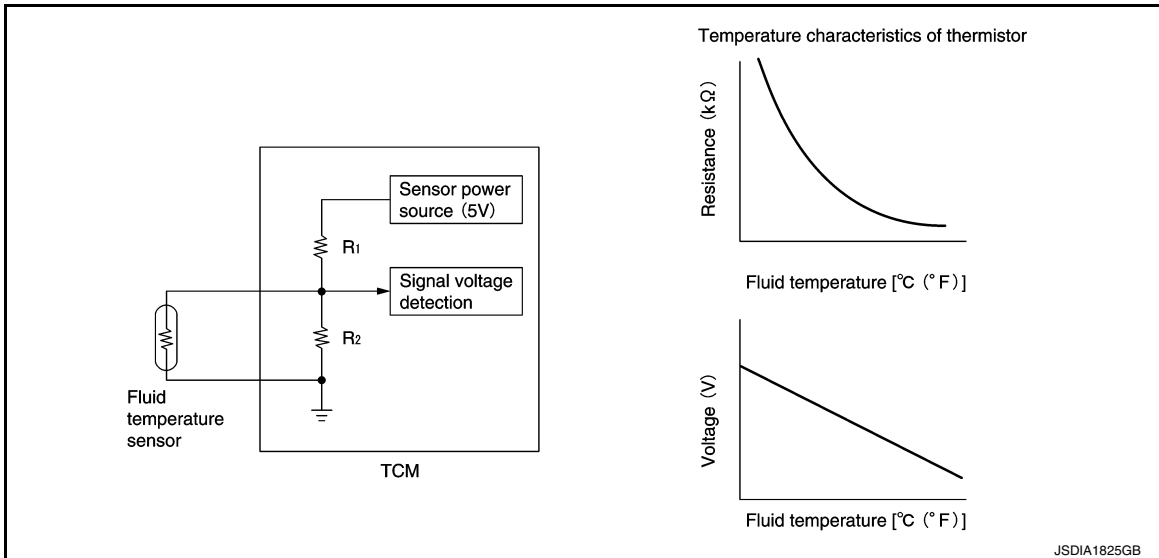

CVT CONTROL SYSTEM : Primary Pressure Sensor

INFOID:0000000011972870

- The primary pressure sensor is installed to control valve.
- The primary pressure sensor detects the pressure applied to the primary pulley.
- When pressure is applied to the ceramic device in the primary pressure sensor, the ceramic device is deformed, resulting in voltage change. TCM evaluates the primary pressure from its voltage change. Voltage is increased along with pressure increase.

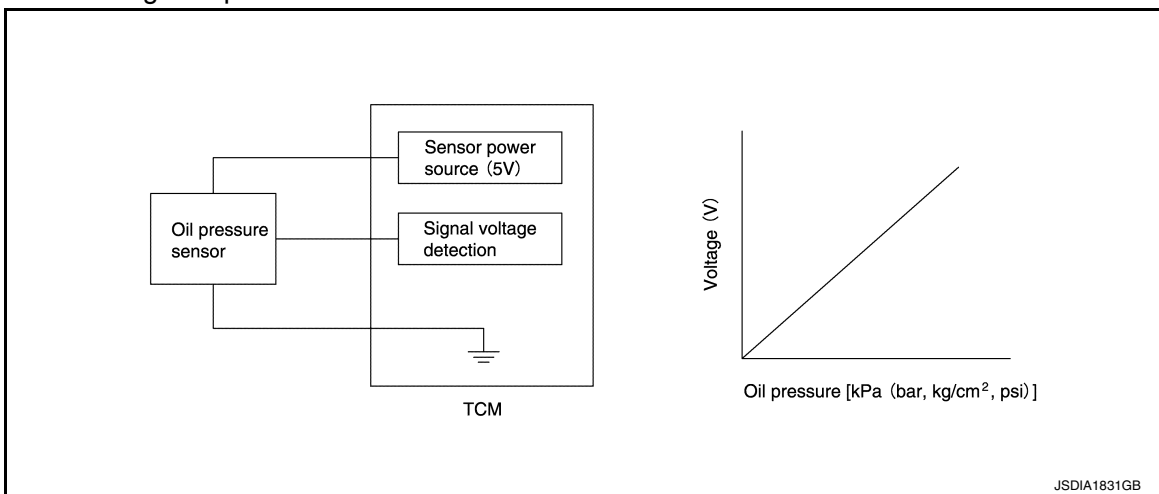

CVT CONTROL SYSTEM : Secondary Pressure Sensor

INFOID:0000000011972871

- The secondary pressure sensor is installed to control valve.
- The secondary pressure sensor detects the pressure applied to the secondary pulley.

COMPONENT PARTS

< SYSTEM DESCRIPTION >

[CVT: RE0F10H]

- When pressure is applied to the metal diaphragm in the secondary pressure sensor, the metal diaphragm is deformed, resulting in voltage change. TCM evaluates the secondary pressure from its voltage change. Voltage is increased along with pressure increase.

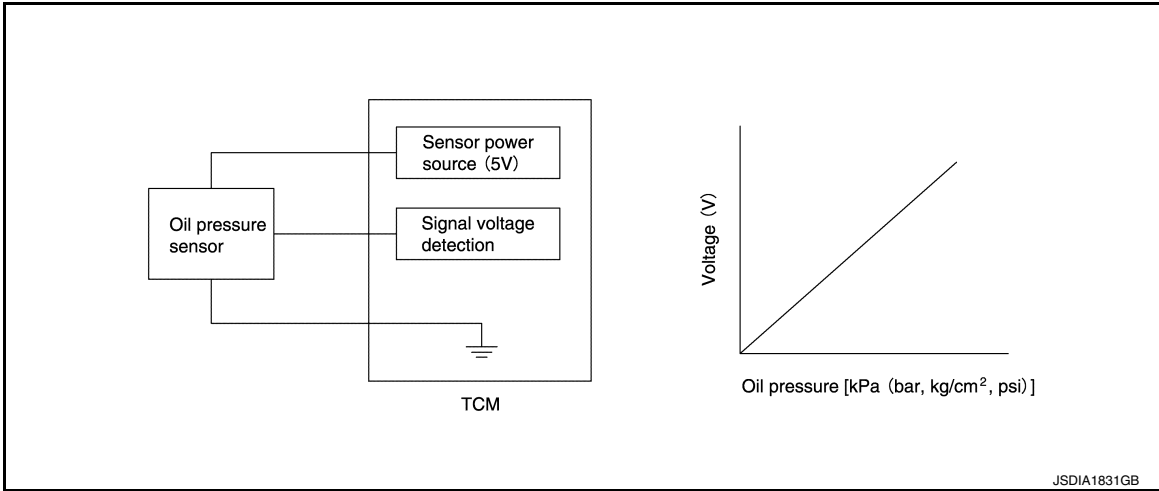

CVT CONTROL SYSTEM : Primary Pressure Solenoid Valve

INFOID:0000000011972872

- The primary pressure solenoid valve is installed to control valve.
- The primary pressure solenoid valve controls the primary reducing valve. For information about the primary reducing valve, refer to [TM-24, "TRANSAXLE : Component Description"](#).
- The primary pressure solenoid valve uses the linear solenoid valve [N/H (normal high) type].

NOTE:

- The principle of the linear solenoid valve utilizes the fact that the force pressing on the valve spool installed inside the coil increases nearly in proportion to the current. This allows it to produce a fluid pressure that is proportional to this pressing force.
- The N/H (normal high) produces hydraulic control when the coil is not energized.

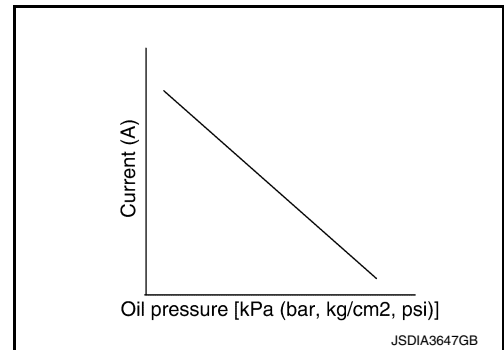

CVT CONTROL SYSTEM : Secondary Pressure Solenoid Valve

INFOID:0000000011972873

- The secondary pressure solenoid valve is installed to control valve.
- The secondary pressure solenoid valve controls the secondary reducing valve. For information about the secondary reducing valve, refer to [TM-24, "TRANSAXLE : Component Description"](#).
- The secondary pressure solenoid valve uses the linear solenoid valve [N/H (normal high) type].

NOTE:

- The principle of the linear solenoid valve utilizes the fact that the force pressing on the valve spool installed inside the coil increases nearly in proportion to the current. This allows it to produce a fluid pressure that is proportional to this pressing force.
- The N/H (normal high) produces hydraulic control when the coil is not energized.

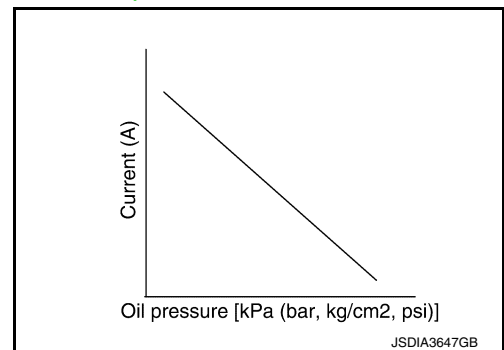

CVT CONTROL SYSTEM : Select Solenoid Valve

INFOID:0000000011972874

- The select solenoid valve is installed to control valve.
- The select solenoid valve adjusts the tightening pressure of the forward clutch and reverse brake. For information about the forward clutch and reverse brake, refer to [TM-24, "TRANSAXLE : Component Description"](#).

COMPONENT PARTS

< SYSTEM DESCRIPTION >

[CVT: RE0F10H]

- The select solenoid valve uses the linear solenoid valve [N/H (normal high) type].

NOTE:

- The principle of the linear solenoid valve utilizes the fact that the force pressing on the valve spool installed inside the coil increases nearly in proportion to the current. This allows it to produce a fluid pressure that is proportional to this pressing force.
- The N/H (normal high) type produces hydraulic control when the coil is not energized.

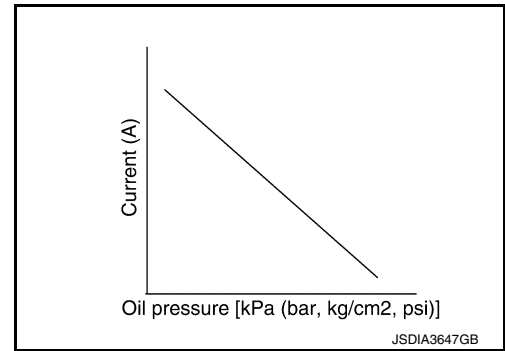

CVT CONTROL SYSTEM : Torque Converter Clutch Solenoid Valve

INFOID:000000011972875

- The torque converter clutch solenoid valve is installed to control valve.
- The torque converter clutch solenoid valve controls the torque converter clutch control valve. For information about the torque converter clutch control valve, refer to [TM-24. "TRANSAXLE : Component Description"](#).
- The torque converter clutch solenoid valve utilizes a linear solenoid valve [N/L (normal low) type].

NOTE:

- The principle of the linear solenoid valve utilizes the fact that the force pressing on the valve spool installed inside the coil increases nearly in proportion to the current. This allows it to produce a fluid pressure that is proportional to this pressing force.
- The N/L (normal low) type does not produce hydraulic control when the coil is not energized.

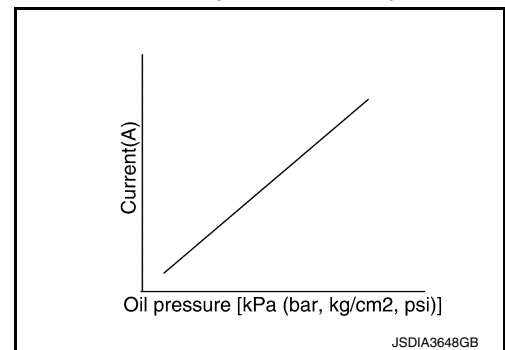

CVT CONTROL SYSTEM : Line Pressure Solenoid Valve

INFOID:000000011972876

- The line pressure solenoid valve is installed to control valve.
- The line pressure solenoid valve controls the pressure regulator valve. For information about the pressure regulator valve, refer to [TM-24. "TRANSAXLE : Component Description"](#).
- The line pressure solenoid valve uses the linear solenoid valve [N/H (normal high) type].

NOTE:

- The principle of the linear solenoid valve utilizes the fact that the force pressing on the valve spool installed inside the coil increases nearly in proportion to the current. This allows it to produce a fluid pressure that is proportional to this pressing force.
- The N/H (normal high) produces hydraulic control when the coil is not energized.

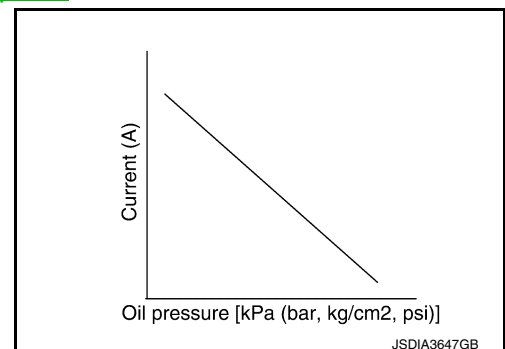

CVT CONTROL SYSTEM : Manual Mode Switch

INFOID:000000012269452

- The manual mode switch is installed in the CVT shift selector assembly.
- The manual mode switch detects the position (the main shift gate side or manual shift gate side) of the selector lever and transmits a manual mode signal or a not manual mode signal to the combination meter. Then, the TCM receives a manual mode signal or non-manual mode signal from the combination meter.
- The manual mode switch detects that the selector lever is shifted to the shift-up side of the manual shift gate and transmits a manual mode shift up signal to the combination meter. Then, the TCM receives a manual mode shift up signal from the combination meter.
- The manual mode switch detects that the selector lever is shifted to the shift-down side of the manual shift gate and transmits a manual mode shift down signal to the combination meter. Then, the TCM receives a manual mode shift down signal from the combination meter.

COMPONENT PARTS

< SYSTEM DESCRIPTION >

[CVT: RE0F10H]

CVT CONTROL SYSTEM : Paddle Shifter

INFOID:000000011972877

- The paddle shifter is installed to the steering.
- The paddle shifter transmits shift up and shift down signals to the combination meter. Then TCM receives signals from the combination meter via CAN communication.

CVT CONTROL SYSTEM : Shift Position Indicator

INFOID:000000011972878

TCM transmits shift position signal to combination meter via CAN communication. The actual shift position is displayed on combination meter according to the signal.

SHIFT LOCK SYSTEM

SHIFT LOCK SYSTEM : Component Parts Location

INFOID:000000011972879

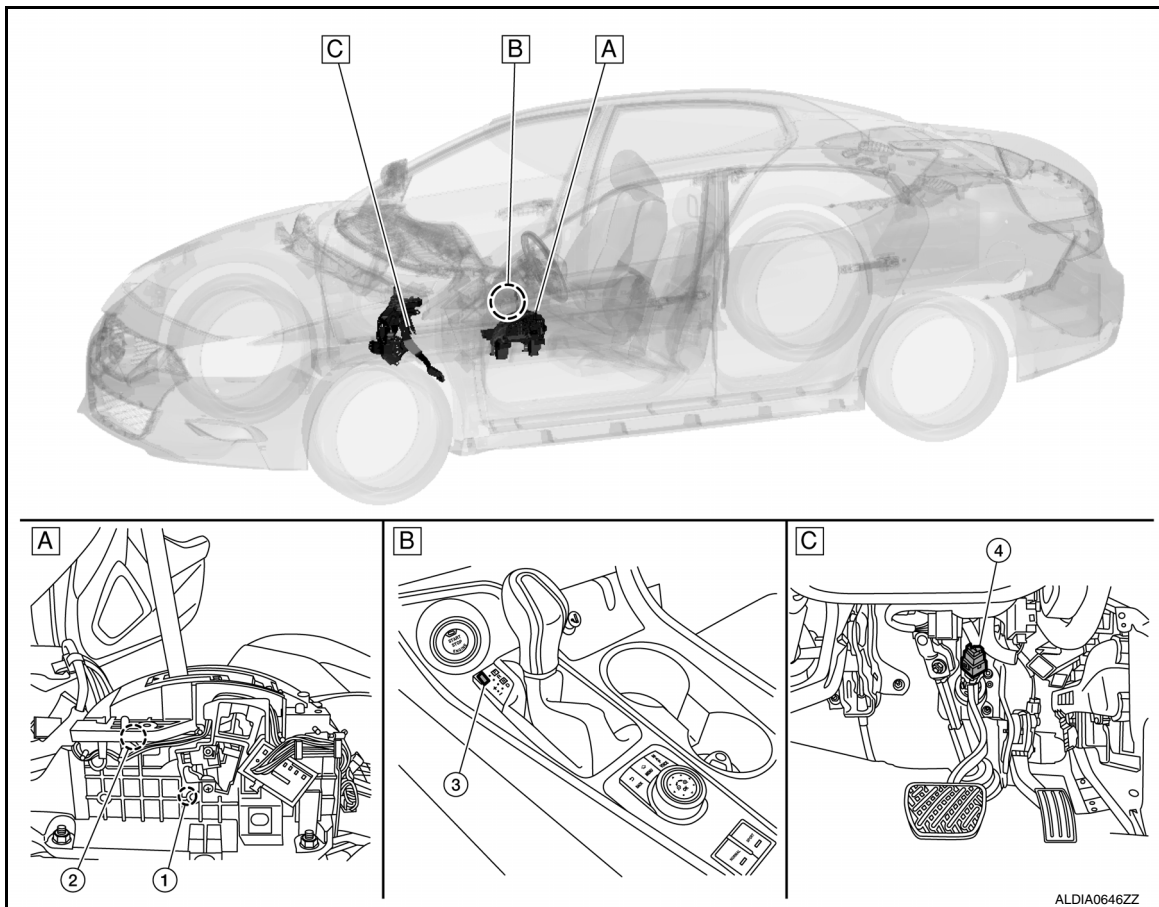

- A. Between front seats (view with center console removed) B. View with instrument panel removed C. Brake pedal area

COMPONENT DESCRIPTION

No.	Component	Function
1.	Park position switch (shift selector)	It detects that the selector lever is in "P" position.
2.	Shift lock solenoid	It operates according to the signal from the stop lamp switch and moves the lock lever.
3.	Shift lock release button	Forcibly releases the shift lock when pressed.
4.	Stop lamp switch	<ul style="list-style-type: none"> • The stop lamp switch turns ON when the brake pedal is depressed. • When the stop lamp switch turns ON, the shift lock solenoid is energized.

STRUCTURE AND OPERATION

< SYSTEM DESCRIPTION >

[CVT: RE0F10H]

STRUCTURE AND OPERATION

TRANSAXLE

TRANSAXLE : Cross-Sectional View

INFOID:000000011972880

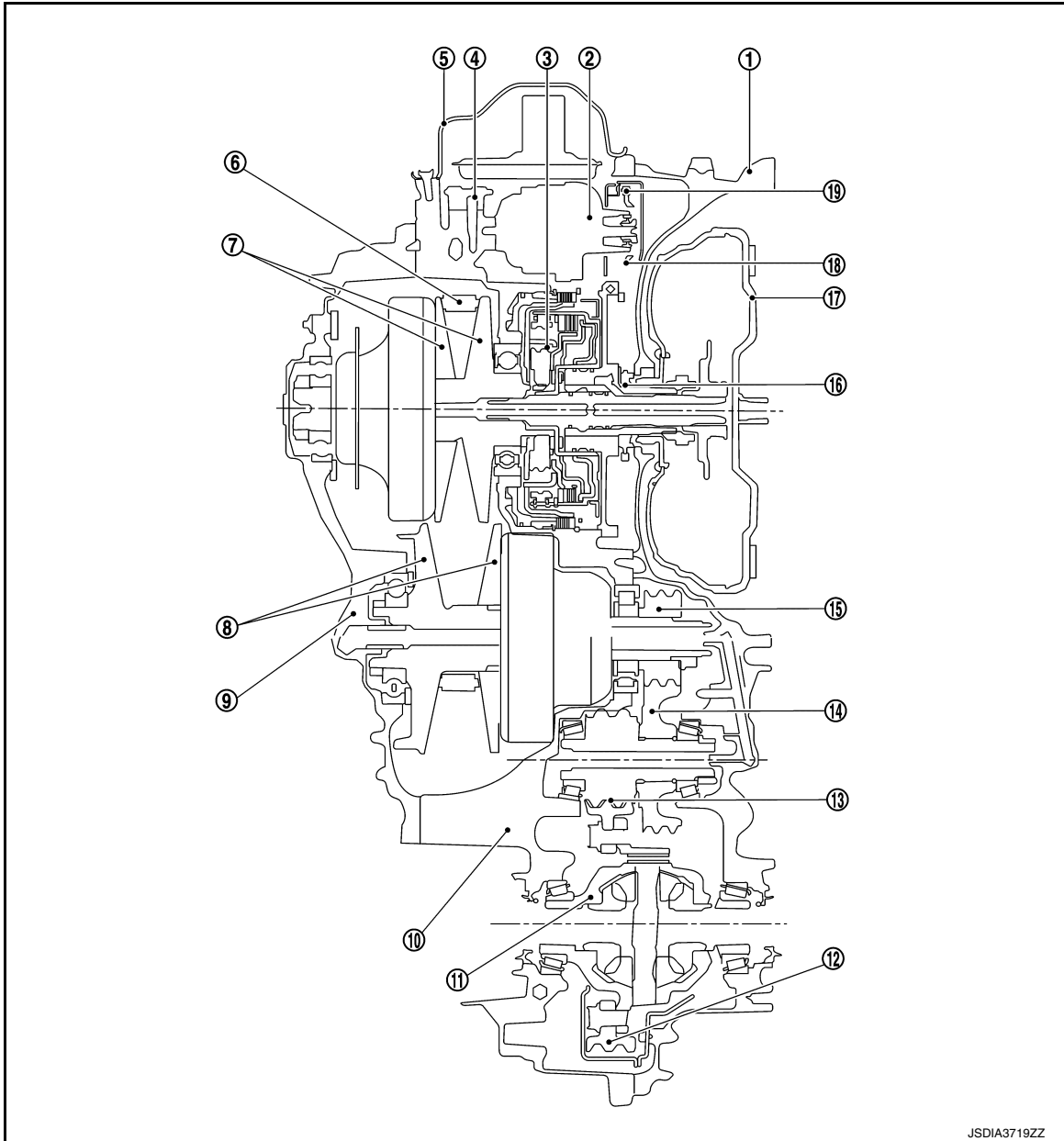

JSDIA3719ZZ

- | | | |
|---------------------|---------------------|-------------------|
| ① Converter housing | ② Oil pump | ③ Planetary gear |
| ④ Control valve | ⑤ Oil pan | ⑥ Chain belt |
| ⑦ Primary pulley | ⑧ Secondary pulley | ⑨ Side cover |
| ⑩ Transaxle case | ⑪ Differential case | ⑫ Final gear |
| ⑬ Reduction gear | ⑭ Idler gear | ⑮ Output gear |
| ⑯ Drive sprocket | ⑰ Torque converter | ⑱ Driven sprocket |
| ⑲ Oil pump chain | | |

STRUCTURE AND OPERATION

< SYSTEM DESCRIPTION >

[CVT: RE0F10H]

TRANSAXLE : Operation Status

INFOID:000000011972881

×: Engaged or applied.

Selector lever position	Parking mechanism	Forward clutch	Reverse brake	Primary pulley	Secondary pulley	Chain belt	Final drive
P	×						
R			×	×	×	×	×
N							
D, M		×		×	×	×	×

TRANSAXLE : Transaxle Mechanism

INFOID:000000011972882

TORQUE CONVERTER (WITH LOCK-UP FUNCTION)

In the same way as a conventional A/T, the torque converter is a system that increases the engine torque and transmits the torque to the transaxle. A symmetrical 3-element, 1-stage, 2-phase type is used here.

OIL PUMP

Utilizes a vane-type oil pump that is driven by the engine through the oil pump drive chain in order to increase efficiency of pump discharge volume in low-speed zone and optimize pump discharge volume in high-speed zone. Discharged oil from oil pump is transmitted to control valve. It is used as the oil of primary and secondary pulley operation, the oil of clutch operation, and the lubricant for each part.

PLANETARY GEAR

- A planetary gear type of forward/reverse selector mechanism is installed between the torque converter and primary pulley.
- The power from the torque converter is input via the input shaft, operating a wet multi-plate clutch by means of hydraulic pressure to switch between forward and reverse driving.

Operation of Planetary gear

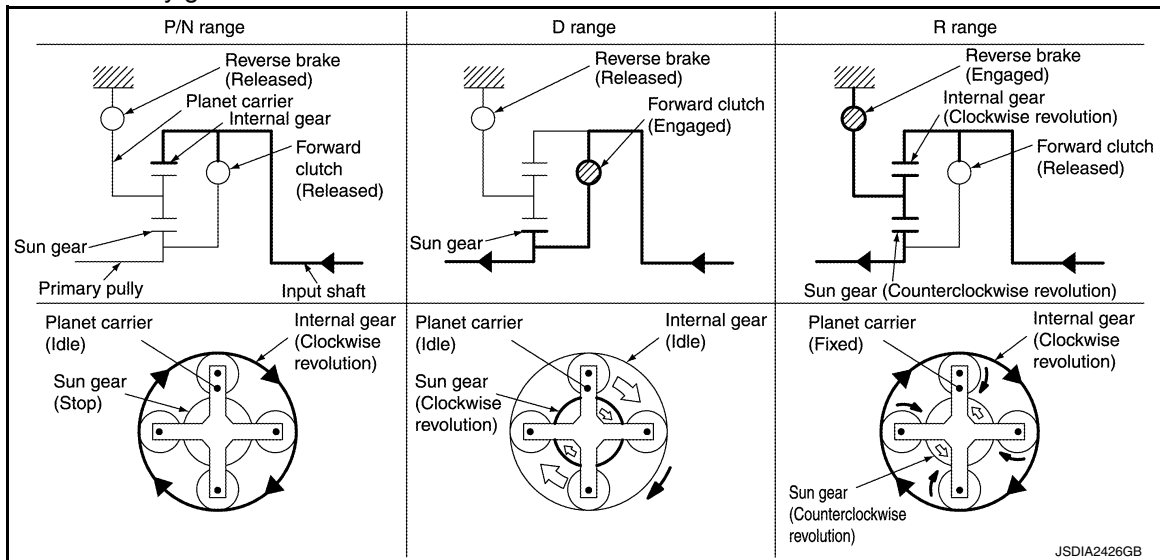

BELT & PULLEY

It is composed of a pair of pulleys (the groove width is changed freely in the axial direction) and the chain belt. The groove width changes according to wrapping radius of chain belt and pulley from low status to overdrive status continuously with non-step. It is controlled with the oil pressures of primary pulley and secondary pulley.

Chain belt

STRUCTURE AND OPERATION

< SYSTEM DESCRIPTION >

[CVT: RE0F10H]

The chain belt consists of approximately 150 locker pins ① and 1,000 link plates ②. Chains are rotated by locker pins sandwiched by pulleys. This produces tension difference in chains among pulleys. Accordingly, the power is transferred by the tension.

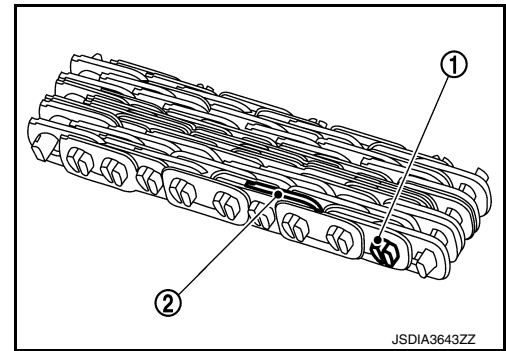

Pulley

The primary pulley (input shaft side) and the secondary pulley (output shaft side) have the shaft with slope (fixed cone surface), movable sheave (movable cone surface that can move in the axial direction) and oil pressure chamber at the back of the movable sheave.

The movable sheave slides on the shaft to change the groove width of the pulley. Input signals of engine load (accelerator pedal opening), primary pulley speed and secondary pulley speed change the operation pressures of the primary pulley and the secondary pulley, and controls the pulley groove width.

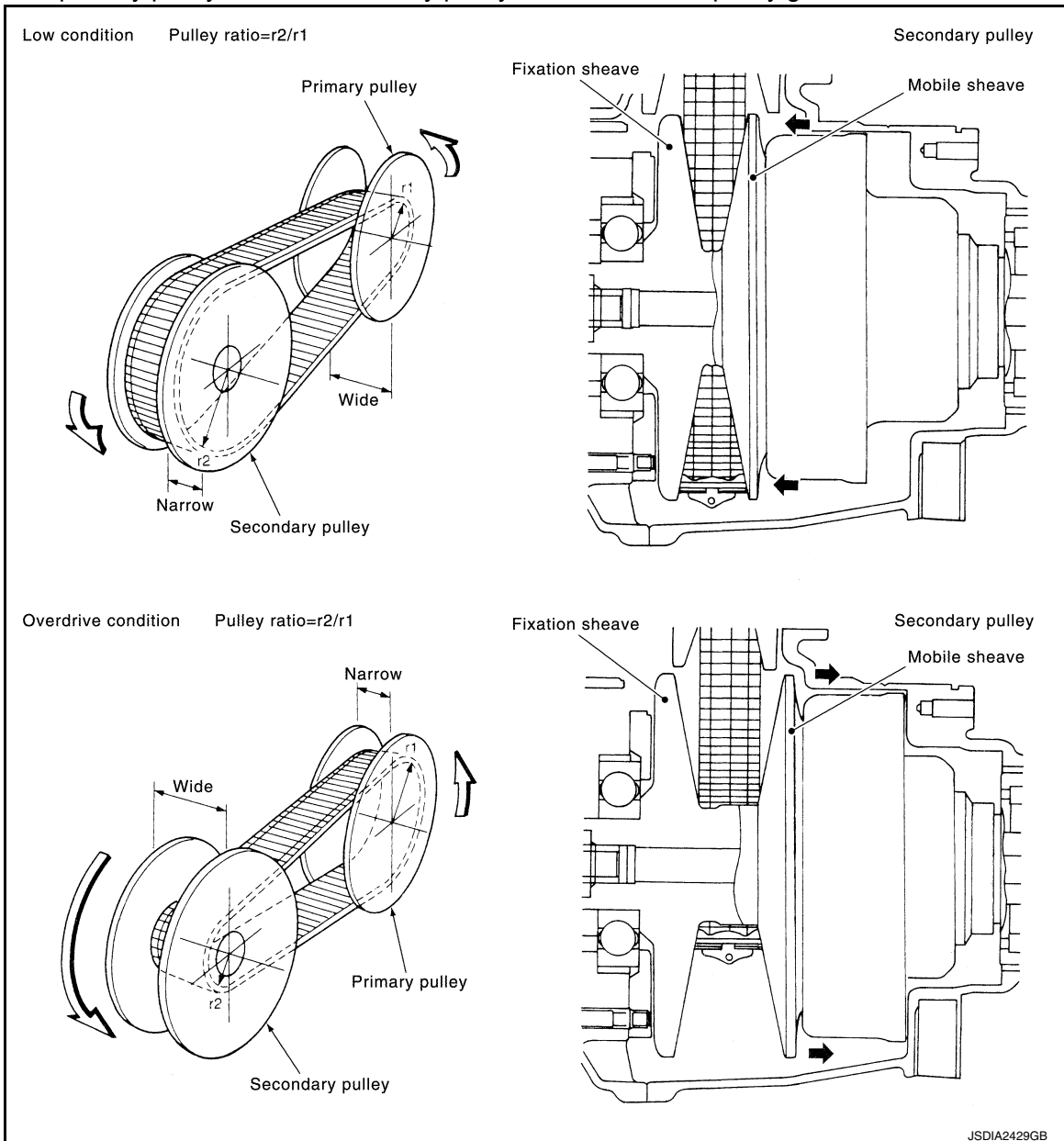

FINAL DRIVE AND DIFFERENTIAL

STRUCTURE AND OPERATION

< SYSTEM DESCRIPTION >

[CVT: RE0F10H]

The deceleration gears are composed of 2 stages: primary deceleration (output gear, idler gear pair) and secondary deceleration (reduction gear, final gear pair). All of these gears are helical gears. The lubrication oil is the same as the CVT fluid which lubricates the entire transaxle.

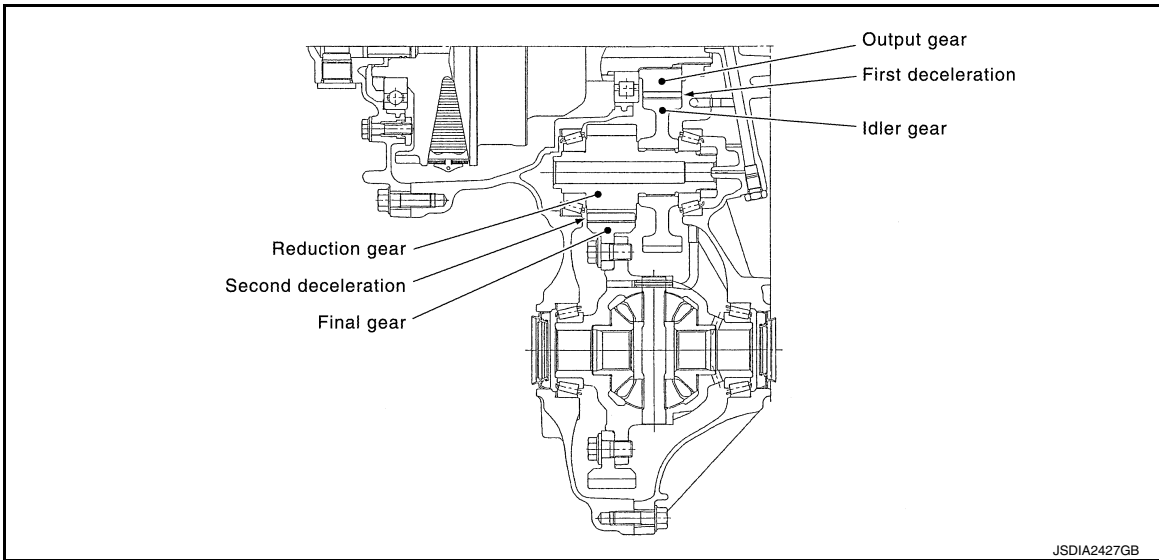

TRANSAXLE : Oil Pressure System

INFOID:000000011972883

Oil pressure required for operation of the transaxle transmission mechanism is generated by oil pump, oil pressure control valve, solenoid valve, etc.

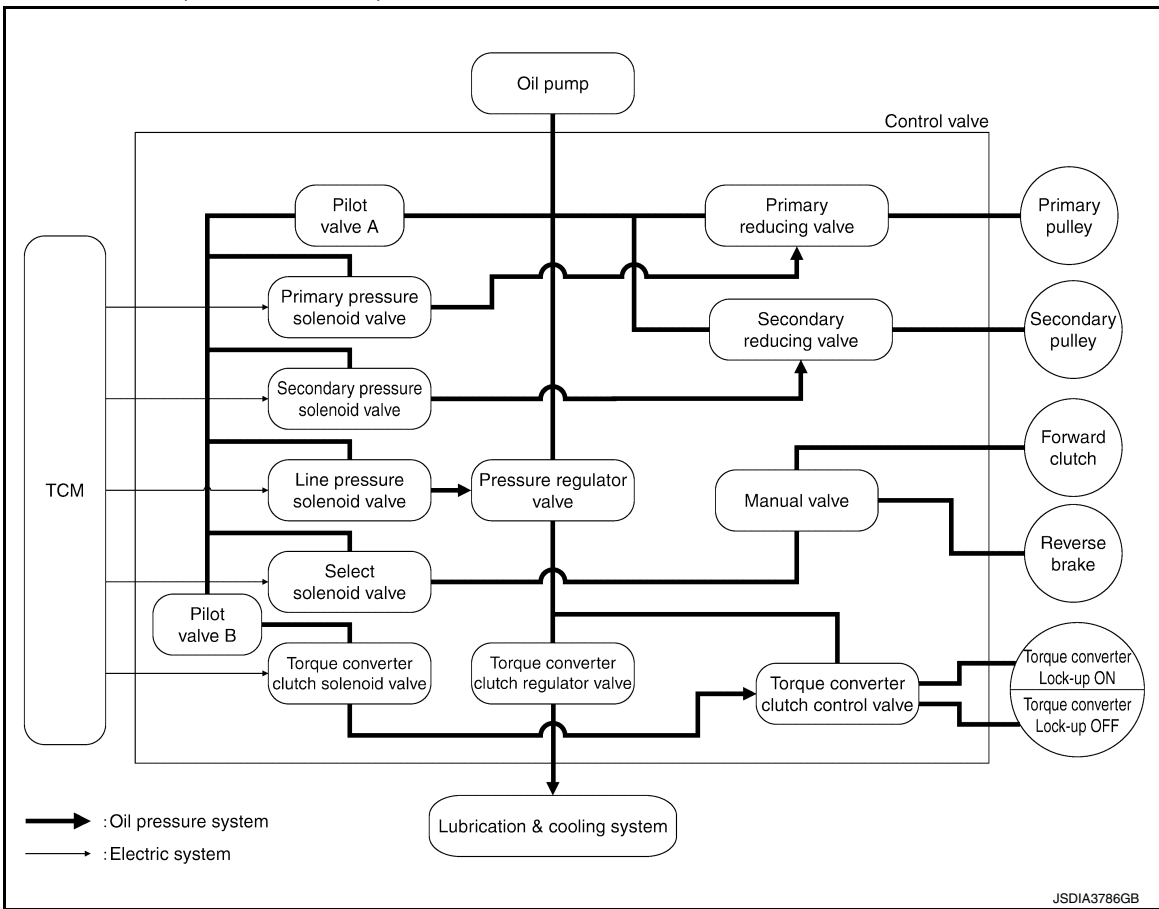

STRUCTURE AND OPERATION

< SYSTEM DESCRIPTION >

[CVT: RE0F10H]

TRANSAXLE : Component Description

INFOID:000000011972884

Part name	Function
Torque converter	Increases engine torque and transmits it to the transaxle.
Oil pump	Utilizes a vane-type oil pump that is driven by the engine through the oil pump drive chain in order to increase efficiency of pump discharge volume in low-speed zone and optimize pump discharge volume in high-speed zone. Discharged oil from oil pump is transmitted to control valve. It is used as the oil of primary and secondary pulley operation, the oil of clutch operation, and the lubricant for each part.
Forward clutch	The forward clutch is wet and multiple plate type clutch that consists of clutch drum, piston, drive plate, and driven plate. It is a clutch to move the vehicle forward by activating piston hydraulically, engaging plates, and directly connecting sun gear and input shaft.
Reverse brake	The reverse brake is a wet multiple-plate type brake that consists of transaxle case, piston, drive plate, and driven plate. It is a brake to move the vehicle in reverse by activating piston hydraulically, engaging plates, and fixing planetary gear.
Internal gear	The internal gear is directly connected to forward clutch drum. It is a gear that moves the outer edge of pinion planet of planet carrier. It transmits power to move the vehicle in reverse when the planet carrier is fixed.
Planet carrier	Composed of a carrier, pinion planet, and pinion shaft. This gear fixes and releases the planet carrier in order to switch between forward and reverse driving.
Sun gear	Sun gear is a set part with planet carrier and internal gear. It transmits transmitted force to primary fixed sheave. It rotates in forward or reverse direction according to activation of either forward clutch or reverse brake.
Input shaft	The input shaft is directly connected to forward clutch drum and transmits traction force from torque converter. In shaft center, there are holes for hydraulic distribution to primary pulley and hydraulic distribution for lockup ON/OFF.
Primary pulley	It is composed of a pair of pulleys (the groove width is changed freely in the axial direction) and the chain belt. The groove width changes according to wrapping radius of steel belt and pulley from low status to overdrive status continuously with non-step. It is controlled with the oil pressures of primary pulley and secondary pulley.
Secondary pulley	
Chain belt	
Manual shaft	When the manual shaft is in the P position, the parking rod that is linked to the manual shaft rotates the parking pole. When the parking pole rotates, it engages with the parking gear, fixing the parking gear. As a result, the secondary pulley that is integrated with the parking gear is fixed.
Parking rod	
Parking pawl	
Parking gear	
Output gear	The deceleration gears are composed of 2 stages: primary deceleration (output gear, idler gear pair) and secondary deceleration (reduction gear, final gear pair). All of these gears are helical gears.
Idler gear	
Reduction gear	
Differential	
Torque converter regulator valve	Adjusts the feed pressure to the torque converter to the optimum pressure corresponding to the driving condition.
Pressure regulator valve	Adjusts the discharge pressure from the oil pump to the optimum pressure (line pressure) corresponding to the driving condition.
Torque converter clutch control valve	Adjusts the torque converter engage and disengage pressures.
Manual valve	Distributes the clutch operation pressure to each circuit according to the selector lever position.
Secondary reducing valve	Reduces line pressure and adjusts secondary pressure.
Primary reducing valve	Reduces line pressure and adjusts primary pressure.
Pilot valve A	Reduces line pressure and adjusts pilot pressure to the solenoid valves listed below. <ul style="list-style-type: none"> • Primary pressure solenoid valve • Secondary pressure solenoid valve • Select solenoid valve • Line pressure solenoid valve
Pilot valve B	Reduces pilot pressure and adjusts pilot pressure to the torque converter clutch solenoid valve.

FLUID COOLER & FLUID WARMER SYSTEM

STRUCTURE AND OPERATION

< SYSTEM DESCRIPTION >

[CVT: RE0F10H]

FLUID COOLER & FLUID WARMER SYSTEM : System Description

INFOID:000000011972885

CVT FLUID COOLER SCHEMATIC

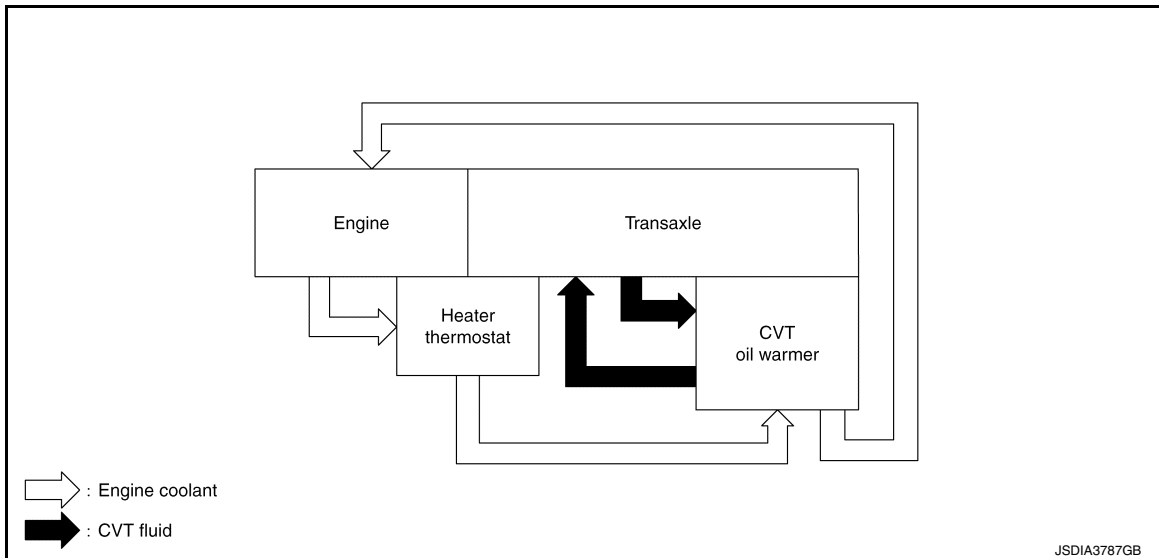

COMPONENT DESCRIPTION

CVT Oil Warmer

- The CVT oil warmer (1) is installed on the front part of transaxle assembly.
- When engine is started while engine and CVT are cold, engine coolant temperature rises more quickly than CVT fluid temperature. CVT oil warmer is provided with two circuits for CVT and engine coolant respectively so that warmed engine coolant warms CVT quickly. This helps shorten CVT warming up time, improving fuel economy.
- A cooling effect is obtained when CVT fluid temperature is high.

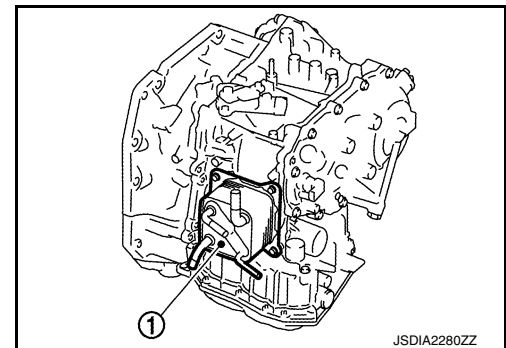

Heater Thermostat

- The heater thermostat (1) is installed on the front part of transaxle assembly.
- The heater thermostat open and close with set temperature.

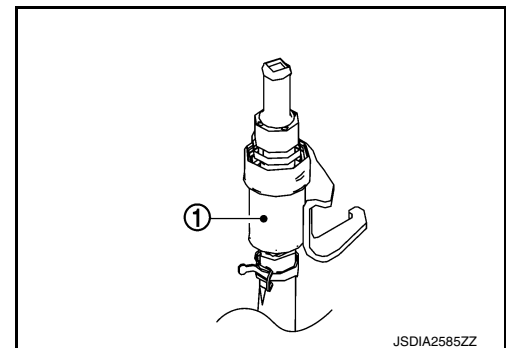

SHIFT LOCK SYSTEM

SHIFT LOCK SYSTEM : System Description

INFOID:000000011972886

The shift lever cannot be shifted from the "P" position unless the brake pedal is depressed while the ignition switch is set to ON. The shift lock is unlocked by turning the shift lock solenoid ON when the ignition switch is set to ON, the park position switch (shift selector) is turned ON (selector lever is in "P" position), and the stop lamp switch is turned ON (brake pedal is depressed) as shown in the operation chart in the figure. Therefore, the shift lock solenoid receives no ON signal and the shift lock remains locked if all of the above conditions are not fulfilled. However, selector operation is allowed if the shift lock release button is pressed.

A
B
C
TM
E
F
G
H
I
J
K
L
M
N
O
P

STRUCTURE AND OPERATION

< SYSTEM DESCRIPTION >

[CVT: RE0F10H]

SHIFT LOCK OPERATION AT "P" POSITION

When Brake Pedal Is Not Depressed (No Selector Operation Allowed)

The shift lock solenoid (A) is turned OFF (not energized) and the solenoid rod (B) is extended with the spring when the brake pedal is not depressed (no selector operation allowed) with the ignition switch ON.

The connecting lock lever (C) is located at the position shown in the figure when the solenoid rod is extended. It prevents the movement of the detent rod (D). For these reasons, the selector lever cannot be shifted from the "P" position.

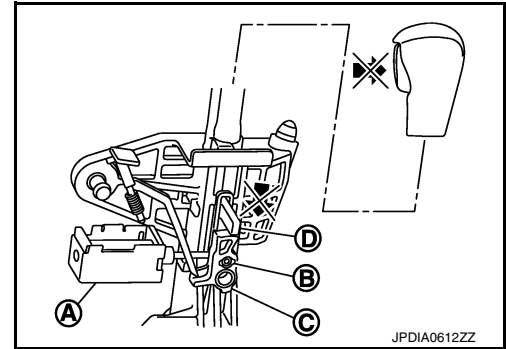

When Brake Pedal Is Depressed (Shift Operation Allowed)

The shift lock solenoid (A) is turned ON (energized) when the brake pedal is depressed with the ignition switch ON. The solenoid rod (B) is compressed by the electromagnetic force. The connecting lock lever (C) rotates when the solenoid is activated. Therefore, the detent rod (D) can be moved. For these reasons, the selector lever can be shifted to other positions.

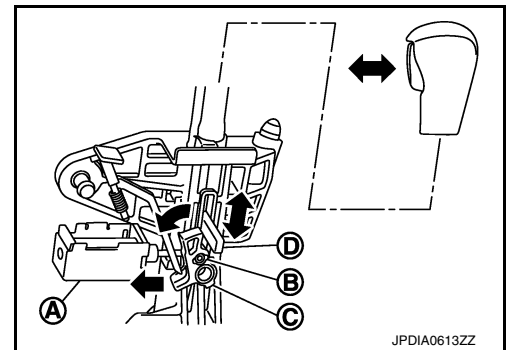

"P" POSITION HOLD MECHANISM (IGNITION SWITCH LOCK)

The shift lock solenoid (A) is not energized when the ignition switch is in any position other than ON. In this condition, the shift mechanism is locked and "P" position is held. The operation cannot be performed from "P" position if the brake pedal is depressed with the ignition switch ON when the operation system of shift lock solenoid is malfunctioning. However, the lock lever (B) is forcibly rotated and the shift lock is released when the shift lock release button (C) is pressed from above. Then the selector operation from "P" position can be performed.

D : Detent rod

CAUTION:

Use the shift lock release button only when the selector lever cannot be operated even if the brake pedal is depressed with the ignition switch ON.

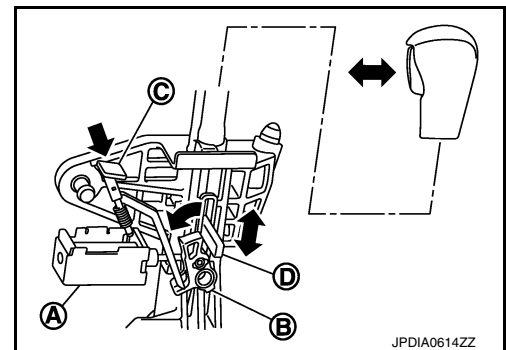

SYSTEM

CVT CONTROL SYSTEM

CVT CONTROL SYSTEM : System Description

INFOID:000000011972887

SYSTEM DIAGRAM

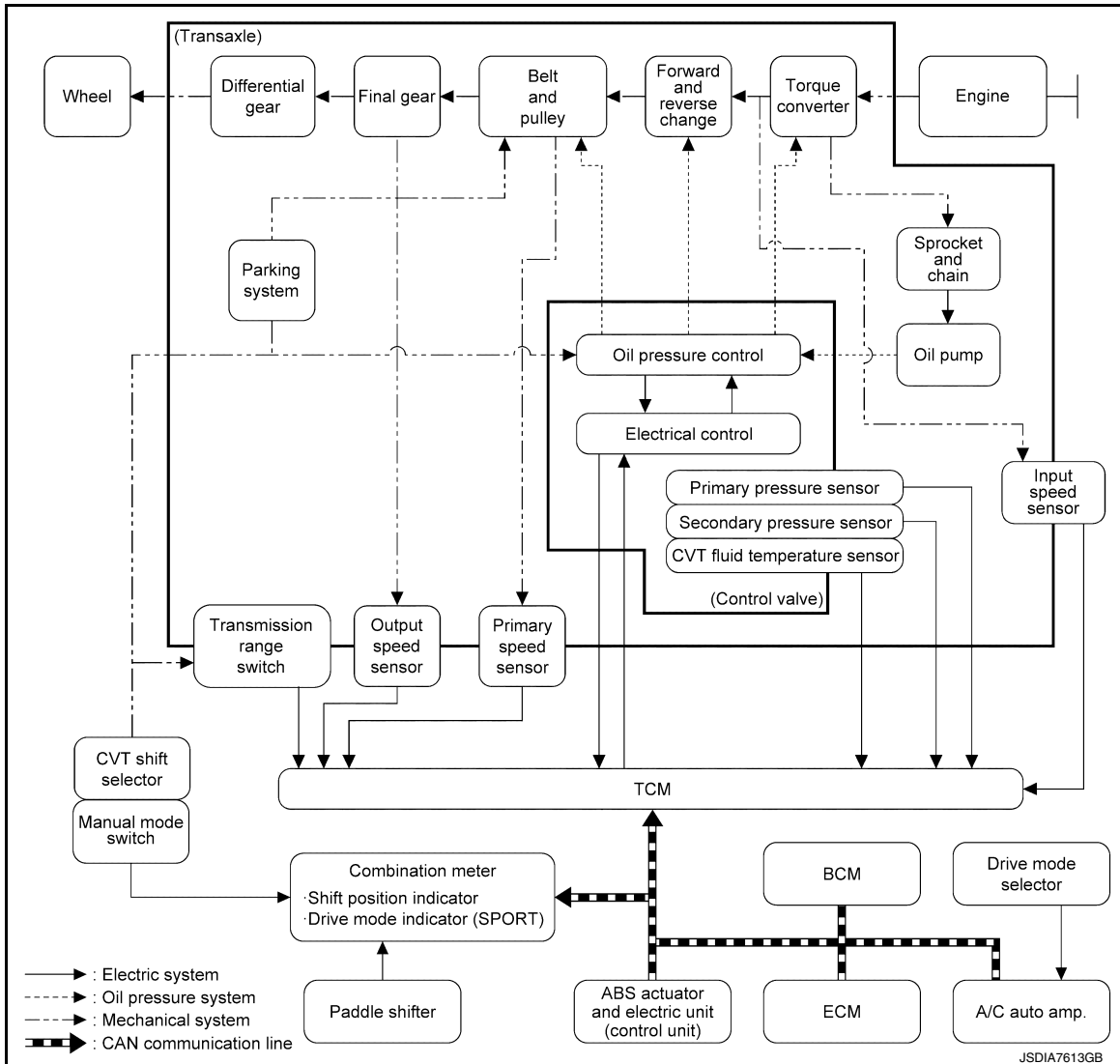

MAIN CONTROL CONTENTS OF TCM

Controls	Reference
Line pressure control	TM-32. "LINE PRESSURE CONTROL : System Description"
Shift control	TM-33. "SHIFT CONTROL : System Description"
Select control	TM-36. "SELECT CONTROL : System Description"
Lock-up control	TM-36. "LOCK-UP CONTROL : System Description"
Drive mode selector	DMS-7. "DRIVE MODE SELECTOR : System Description"
Fail-safe	TM-53. "Fail-safe"
Self-diagnosis function	TM-42. "CONSULT Function"
Communication function with CONSULT	TM-42. "CONSULT Function"

SYSTEM DESCRIPTION

A
B
C
TM
E
F
G
H
I
J
K
L
M
N
O
P

SYSTEM

[CVT: RE0F10H]

< SYSTEM DESCRIPTION >

- CVT detects the vehicle driving status from switches, sensors and signals, and controls the vehicle so that the optimum shift position and shift timing may always be achieved. It also controls the vehicle to reduce shift and lockup shock, etc.
- Receives input signals from switches and sensors.
- Sends the output signal necessary for operation of solenoid valves, and evaluates the line pressure, shift timing, lockup operation, engine brake performance, etc.
- If a malfunction occurs on the electric system, activate the fail-safe mode only to drive the vehicle.

LIST OF CONTROL ITEMS AND INPUT/OUTPUT

Control Item		Shift control	Line pressure control	Select control	Lock-up control	Fail-safe function*1
Input	Engine and CVT integrated control signal (engine torque)*2	×	×	×	×	×
	Engine speed signal*2	×	×	×	×	×
	Accelerator pedal position signal*2	×	×	×	×	
	Closed throttle position signal*2	×	×		×	
	Stop lamp switch signal*2	×	×	×	×	
	Primary pressure sensor					×
	Secondary pressure sensor	×	×			×
	CVT fluid temperature sensor	×	×	×	×	×
	Primary speed sensor	×	×	×	×	×
	Output speed sensor	×	×		×	×
	Input speed sensor	×	×	×	×	×
	Transmission range switch	×	×	×	×	×
	Manual mode signal*2	×	×		×	
	Non-manual mode signal*2	×	×		×	
	Manual mode shift up signal*2	×	×		×	
	Manual mode shift down signal*2	×	×		×	
	Paddle shifter shift up signal*2	×	×		×	
	Paddle shifter shift down signal*2	×	×		×	
	Drive mode selector signal*2	×	×		×	
Output	Line pressure solenoid valve	×	×	×		×
	Primary pressure solenoid valve	×	×			×
	Torque converter clutch solenoid valve				×	×
	Secondary pressure solenoid valve	×	×			×
	Select solenoid valve	×		×		×
	Shift position signal*2			×		
	Drive mode indicator signal*2	×	×		×	

*1: If these input/output signals show errors, TCM activates the fail-safe function.

*2: CAN communication signal

CVT CONTROL SYSTEM : Fail-safe

INFOID:0000000011972888

TCM has a fail-safe mode. The mode functions so that operation can be continued even if the signal circuit of the main electronically controlled input/output parts is damaged.

If the vehicle shows following behaviors including “poor acceleration”, a malfunction of the applicable system is detected by TCM and the vehicle may be in a fail-safe mode. At this time, check the DTC code and perform inspection and repair according to the malfunction diagnosis procedures.

SYSTEM

< SYSTEM DESCRIPTION >

[CVT: RE0F10H]

Fail-safe function

DTC	Vehicle behavior	Conditions of vehicle	
P062F	<ul style="list-style-type: none"> Not changed from normal driving 	—	A
P0705	<ul style="list-style-type: none"> Shift position indicator on combination meter is not displayed Selector shock is large Start is slow Acceleration is slow Lock-up is not performed 	—	B
			C
P0706	<ul style="list-style-type: none"> Shift position indicator on combination meter is not displayed Selector shock is large Start is slow Acceleration is slow Lock-up is not performed 	—	TM
P0711	<ul style="list-style-type: none"> Start is slow Acceleration is slow 	Engine coolant temperature when engine start: Temp. $\geq 10^{\circ}\text{C}$ (50°F)	E
	<ul style="list-style-type: none"> Selector shock is large Start is slow Acceleration is slow 	Engine coolant temperature when engine start: -35°C (-31°F) \leq Temp. $< 10^{\circ}\text{C}$ (50°F)	F
	<ul style="list-style-type: none"> Selector shock is large Start is slow Acceleration is slow 	Engine coolant temperature when engine star: Temp. $< -35^{\circ}\text{C}$ (-31°F)	G
P0712	<ul style="list-style-type: none"> Start is slow Acceleration is slow 	Engine coolant temperature when engine start: Temp. $\geq 10^{\circ}\text{C}$ (50°F)	H
	<ul style="list-style-type: none"> Selector shock is large Start is slow Acceleration is slow 	Engine coolant temperature when engine start: -35°C (-31°F) \leq Temp. $< 10^{\circ}\text{C}$ (50°F)	I
	<ul style="list-style-type: none"> Selector shock is large Start is slow Acceleration is slow 	Engine coolant temperature when engine star: Temp. $< -35^{\circ}\text{C}$ (-31°F)	J
P0713	<ul style="list-style-type: none"> Start is slow Acceleration is slow 	Engine coolant temperature when engine start: Temp. $\geq 10^{\circ}\text{C}$ (50°F)	K
	<ul style="list-style-type: none"> Selector shock is large Start is slow Acceleration is slow 	Engine coolant temperature when engine start: -35°C (-31°F) \leq Temp. $< 10^{\circ}\text{C}$ (50°F)	L
	<ul style="list-style-type: none"> Selector shock is large Start is slow Acceleration is slow 	Engine coolant temperature when engine star: Temp. $< -35^{\circ}\text{C}$ (-31°F)	M
P0715	<ul style="list-style-type: none"> Start is slow Acceleration is slow Lock-up is not performed 	—	N
P0717	<ul style="list-style-type: none"> Start is slow Acceleration is slow Lock-up is not performed 	—	O
P0740	<ul style="list-style-type: none"> Start is slow Acceleration is slow Lock-up is not performed 	—	P
P0743	<ul style="list-style-type: none"> Start is slow Acceleration is slow Lock-up is not performed 	—	
P0744	<ul style="list-style-type: none"> Start is slow Acceleration is slow Lock-up is not performed 	—	

SYSTEM

< SYSTEM DESCRIPTION >

[CVT: RE0F10H]

DTC	Vehicle behavior	Conditions of vehicle
P0746	<ul style="list-style-type: none"> • Selector shock is large • Start is slow • Acceleration is slow • Lock-up is not performed 	—
P0776	<ul style="list-style-type: none"> • Selector shock is large • Start is slow • Acceleration is slow • Lock-up is not performed • Vehicle speed is not increased 	When a malfunction occurs on the low oil pressure side
	<ul style="list-style-type: none"> • Selector shock is large • Start is slow • Acceleration is slow • Lock-up is not performed 	When a malfunction occurs on the high oil pressure side
P0778	<ul style="list-style-type: none"> • Selector shock is large • Start is slow • Acceleration is slow • Lock-up is not performed 	—
P0779	<ul style="list-style-type: none"> • Selector shock is large • Start is slow • Acceleration is slow • Lock-up is not performed 	
P0841	<ul style="list-style-type: none"> • Not changed from normal driving 	
P0847	<ul style="list-style-type: none"> • Not changed from normal driving 	—
P0848	<ul style="list-style-type: none"> • Not changed from normal driving 	—
P084C	<ul style="list-style-type: none"> • Not changed from normal driving 	
P084D	<ul style="list-style-type: none"> • Not changed from normal driving 	
P0863	<ul style="list-style-type: none"> • Selector shock is large • Start is slow • Acceleration is slow • Lock-up is not performed 	—
P0890	<ul style="list-style-type: none"> • Selector shock is large • Start is slow • Acceleration is slow • Lock-up is not performed • Vehicle speed is not increased 	
P0962	<ul style="list-style-type: none"> • Selector shock is large • Start is slow • Acceleration is slow • Lock-up is not performed 	—
P0963	<ul style="list-style-type: none"> • Selector shock is large • Start is slow • Acceleration is slow • Lock-up is not performed 	—
P0965	<ul style="list-style-type: none"> • Selector shock is large • Start is slow • Acceleration is slow • Lock-up is not performed 	When a malfunction occurs on the low oil pressure side
	<ul style="list-style-type: none"> • Selector shock is large • Lock-up is not performed 	When a malfunction occurs on the high oil pressure side
P0966	<ul style="list-style-type: none"> • Selector shock is large • Start is slow • Acceleration is slow • Lock-up is not performed 	—
P0967	<ul style="list-style-type: none"> • Selector shock is large • Start is slow • Acceleration is slow • Lock-up is not performed 	—

SYSTEM

< SYSTEM DESCRIPTION >

[CVT: RE0F10H]

DTC	Vehicle behavior	Conditions of vehicle
P2765	<ul style="list-style-type: none"> Start is slow Acceleration is slow Lock-up is not performed 	—
P2813	<ul style="list-style-type: none"> Selector shock is large Start is slow Acceleration is slow Vehicle speed is not increased 	When a malfunction occurs on the low oil pressure side
	<ul style="list-style-type: none"> Selector shock is large 	When a malfunction occurs on the high oil pressure side
P2814	<ul style="list-style-type: none"> Selector shock is large 	—
P2815	<ul style="list-style-type: none"> Selector shock is large 	—
U0073	<ul style="list-style-type: none"> Selector shock is large Start is slow Acceleration is slow Lock-up is not performed 	—
U0100	<ul style="list-style-type: none"> Selector shock is large Start is slow Acceleration is slow Lock-up is not performed 	—
U0140	<ul style="list-style-type: none"> Not changed from normal driving 	—
U0141	<ul style="list-style-type: none"> Not changed from normal driving 	—
U0155	<ul style="list-style-type: none"> Not changed from normal driving 	—
U0300	<ul style="list-style-type: none"> Selector shock is large Start is slow Acceleration is slow Lock-up is not performed 	—
U1000	<ul style="list-style-type: none"> Not changed from normal driving 	—
U1117	<ul style="list-style-type: none"> Not changed from normal driving 	—

CVT CONTROL SYSTEM : Protection Control

INFOID:000000011972889

The TCM becomes the protection control status temporarily to protect the safety when the safety of TCM and transmission is lost. It automatically returns to the normal status if the safety is secured.
The TCM has the following protection control.

CONTROL FOR WHEEL SPIN

Control	When a wheel spin is detected, the engine output and gear ratio are limited and the line pressure is increased. Limits engine output when a wheel spin occurs in any of right and left drive wheels.
Vehicle behavior in control	If the accelerator is kept depressing during wheel spin, the engine revolution and vehicle speed are limited to a certain degree.
Normal return condition	Wheel spin convergence returns the control to the normal control.

TORQUE IS REDUCED WHEN DRIVING WITH THE REVERSE GEAR

Control	Engine output is controlled according to a vehicle speed while reversing the vehicle.
Vehicle behavior in control	Power performance may be lowered while reversing the vehicle.
Normal return condition	Torque returns to normal by positioning the selector lever in a range other than "R" position.

CONTROL WHEN FLUID TEMPERATURE IS HIGH

SYSTEM

< SYSTEM DESCRIPTION >

[CVT: RE0F10H]

Control	When the CVT fluid temperature is high, the gear shift permission maximum revolution and the maximum torque are reduced than usual to prevent increase of the oil temperature.
Vehicle behavior in control	Power performance may be lowered, compared to normal control.
Normal return condition	The control returns to the normal control when CVT fluid temperature is lowered.

REVERSE PROHIBIT CONTROL

Control	The reverse brake is controlled to avoid becoming engaged when the selector lever is set in "R" position while driving in forward direction at more than the specified speed.
Vehicle behavior in control	If the selector lever is put at "R" position when driving with the forward gear, the gear becomes neutral, not reverse.
Normal return condition	The control returns to normal control when the vehicle is driven at low speeds. (The reverse brake becomes engaged.)

LINE PRESSURE CONTROL

LINE PRESSURE CONTROL : System Description

INFOID:0000000011972890

SYSTEM DIAGRAM

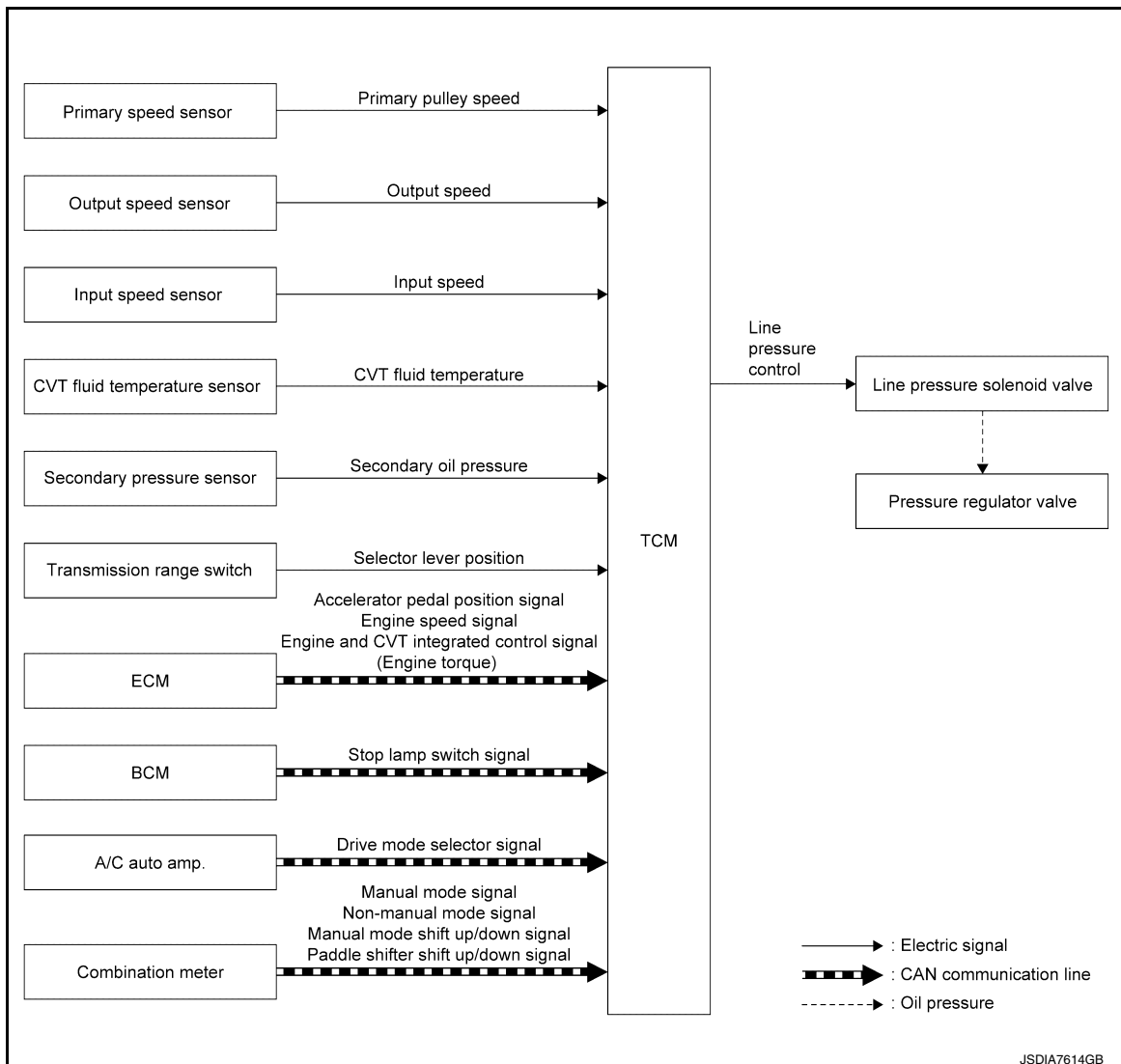

DESCRIPTION

SYSTEM

< SYSTEM DESCRIPTION >

[CVT: RE0F10H]

Highly accurate line pressure control (secondary pressure control) reduces friction for improvement of fuel economy.

A

Normal Oil Pressure Control

Appropriate line pressure and secondary pressure suitable for driving condition are determined based on the accelerator pedal position, engine speed, primary pulley (input) speed, secondary pulley (output) speed, vehicle speed, input torque, stop lamp switch signal, transmission range switch signal, lock-up signal, power voltage, target shift ratio, oil temperature, oil pressure, manual mode signal, non-manual mode signal, manual mode shift up/down signal, paddle shifter shift up/down signal, and drive mode selector signal.

B

C

Secondary Pressure Feedback Control

In normal oil pressure control and oil pressure control in shifting, highly accurate secondary pressure is determined by detecting the secondary pressure using an oil pressure sensor and by feedback control.

TM

SHIFT CONTROL

SHIFT CONTROL : System Description

INFOID:000000011972891

E

SYSTEM DIAGRAM

F

G

H

I

J

K

L

M

N

O

P

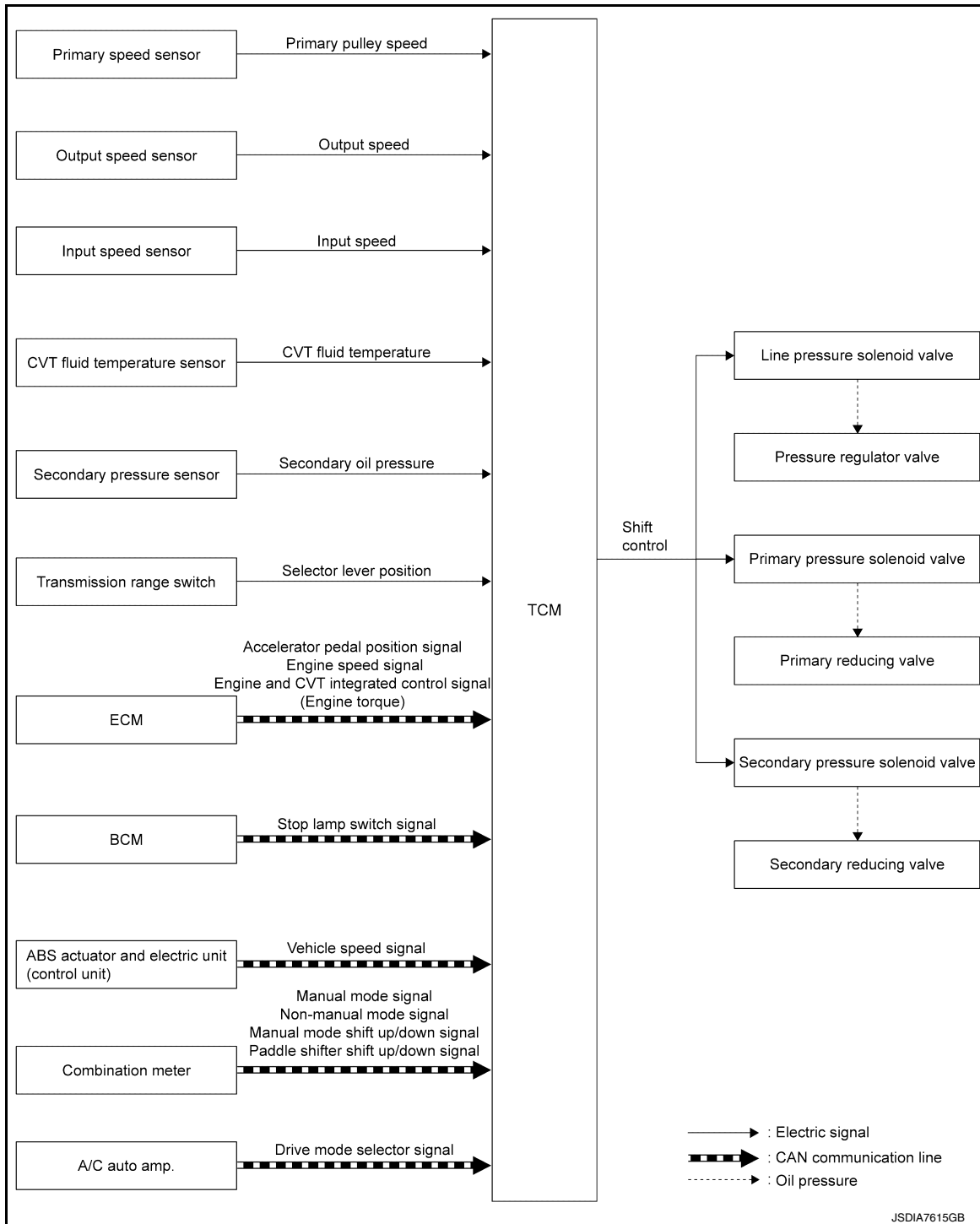

DESCRIPTION

To select the gear ratio that can give the driving force to meet driver's intent or vehicle situation, the vehicle driving condition such as vehicle speed or accelerator pedal position is detected and the most appropriate gear ratio is selected and the shifting method before reaching the speed is determined. The information is output to the primary pressure solenoid valve and secondary pressure solenoid valve to control the line pressure input/output to the pulley, to determine the pulley (movable pulley) position and to control the gear position.

D Position (Normal Mode)

SYSTEM

< SYSTEM DESCRIPTION >

[CVT: RE0F10H]

Gear shifting is performed in all shifting ranges from the lowest to the highest gear ratio.

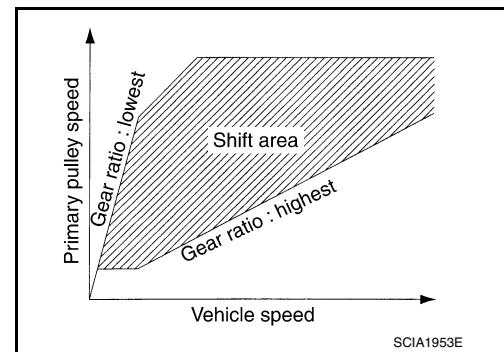

D Position (Sport Mode)

The gear ratio is generally high by limiting the shifting range on the high side, and this always generates a large driving power.

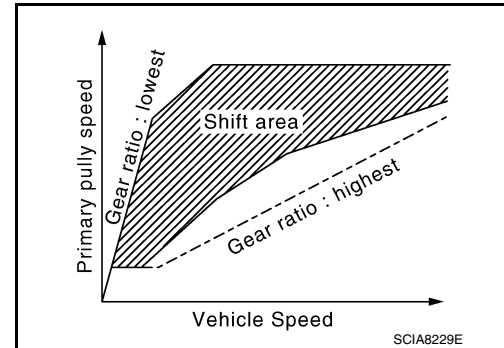

M Position (Manual Mode)

- When the selector lever is shifted to the manual shift gate side or the paddle shifter is operated, the fixed changing gear line is set. By moving the selector lever or paddle shifter to + side or -side, the manual mode switch or paddle shifter is changed over, and shift change like M/T becomes possible following the changing gear set line step by step.

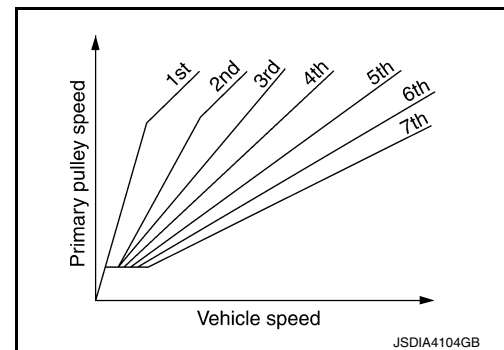

- Manual Mode Information

The TCM transmits the manual mode shift refusal signal to the combination meter if the TCM refuses the transmission from the driving status of vehicle when the selector lever or paddle shifter shifts to UP side (+ side) or DOWN side (-side). The combination meter blinks shift indicator on the combination meter and sounds the buzzer to indicate the driver that the shifting is not performed when receiving this signal. However, the TCM does not transmit the manual mode shift refusal signal in the conditions as per the following.

- When the selector lever or the paddle shifter shifts to DOWN side (-side) while driving in M1.
- When the selector lever or the paddle shifter shifts to UP (+ side) side while driving in M7.

Hill Climbing And Descending Control

If a downhill is detected with the accelerator pedal is released, the system performs downshift to increase the engine brake force so that vehicle may not be accelerated more than necessary. If a climbing hill is detected, the system improves the acceleration performance in re-acceleration by limiting the gear shift range on the high side.

NOTE:

SYSTEM

< SYSTEM DESCRIPTION >

[CVT: RE0F10H]

For engine brake control on a downhill, the control can be stopped with CONSULT.

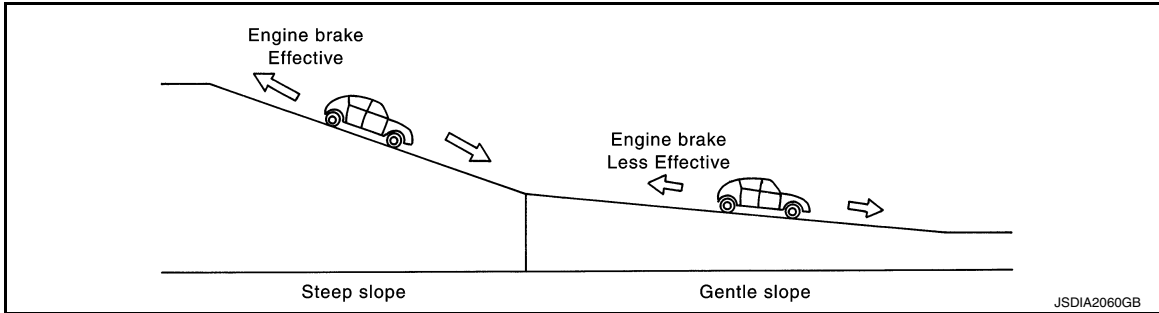

Control In Acceleration

From change of the vehicle speed or accelerator pedal position, the acceleration request level of the driver or driving scene is evaluated. In start or acceleration during driving, the gear shift characteristics with linearity of revolution increase and vehicle speed increase are gained to improve the acceleration feel.

SELECT CONTROL

SELECT CONTROL : System Description

INFOID:000000011972892

SYSTEM DIAGRAM

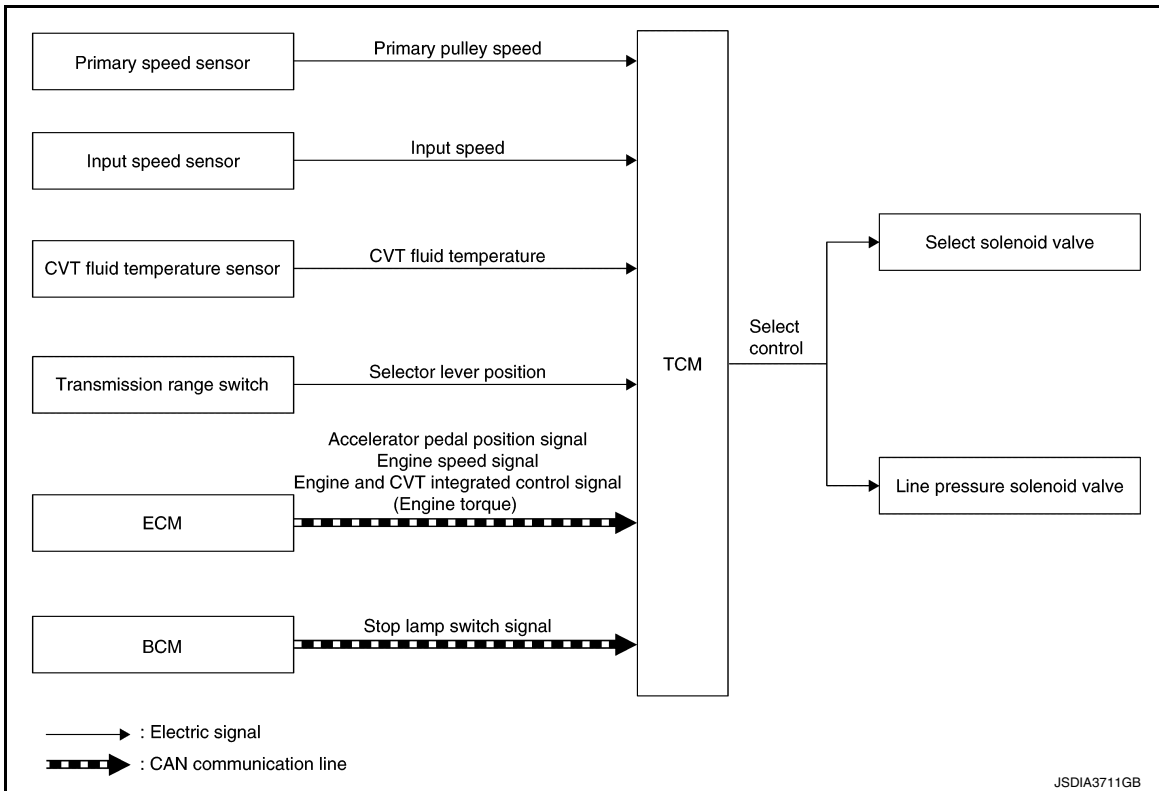

DESCRIPTION

Based on accelerator pedal angle, engine speed, primary pulley speed, and the input speed, the optimum operating pressure is set to reduce impact of a selector lever operation while shifting from "N" ("P") to "D" ("R") position.

LOCK-UP CONTROL

LOCK-UP CONTROL : System Description

INFOID:000000011972893

SYSTEM DIAGRAM

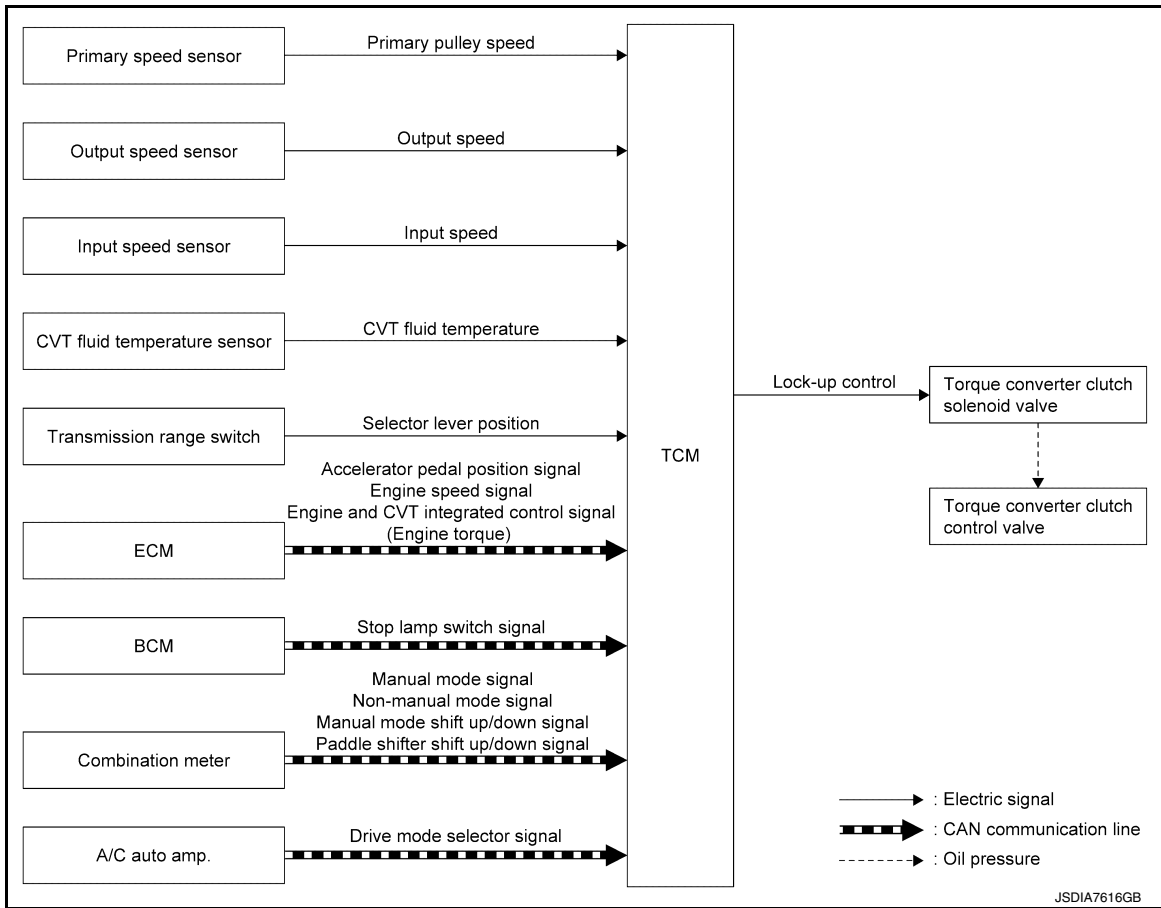

A

B

C

TM

E

F

G

H

I

DESCRIPTION

- Controls for improvement of the transmission efficiency by engaging the torque converter clutch in the torque converter and eliminating slip of the converter. Achieves comfortable driving with slip control of the torque converter clutch.
- The oil pressure feed circuit for the torque converter clutch piston chamber is connected to the torque converter clutch control valve. The torque converter clutch control valve is switched by the torque converter clutch solenoid valve with the signal from TCM. This controls the oil pressure circuit, which is supplied to the torque converter clutch piston chamber, to the release side or engagement side.
- If the CVT fluid temperature is low or the vehicle is in fail-safe mode due to malfunction, lock-up control is prohibited.

J

K

L

Lock-up engagement

In lock-up engagement, the torque converter clutch solenoid valve makes the torque converter clutch control valve locked up to generate the lock-up apply pressure. This pushes the torque converter clutch piston for engagement.

M

Lock-up release condition

In lock-up release, the torque converter clutch solenoid valve makes the torque converter clutch control valve non-locked up to drain the lock-up apply pressure. This does not engage the torque converter clutch piston.

N

INFORMATION DISPLAY (COMBINATION METER)

O

INFORMATION DISPLAY (COMBINATION METER) : Shift Position Indicator

INFOID:000000012274696

P

PURPOSE

The shift position indicator displays the shift position of transmission.

SYSTEM

< SYSTEM DESCRIPTION >

[CVT: RE0F10H]

SYSTEM DIAGRAM

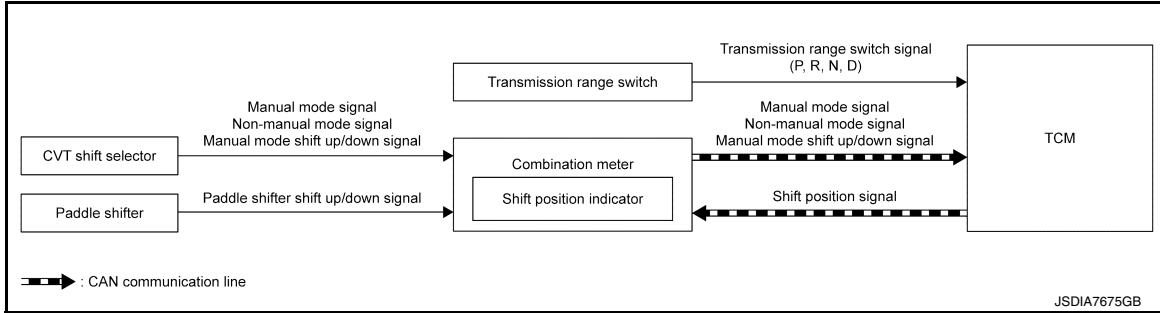

SIGNAL PATH

- The TCM judges the shift position by the transmission range switch signal, manual mode signal, non-manual mode signal, manual mode shift up signal, manual mode shift down signal, paddle shifter shift up signal*, and paddle shifter shift down signal*.
- *: With paddle shifter
- The TCM transmits the shift position signal to the combination meter via CAN communication. The combination meter shows the shift position indicator on the information display, according to the signal.

LIGHTING CONDITION

Ignition switch: ON

SHUTOFF CONDITION

Ignition switch: Other than ON

WARNING/INDICATOR/CHIME LIST

WARNING/INDICATOR/CHIME LIST : Warning Lamp/Indicator Lamp

INFOID:000000012269550

Name	Design	Arrangement/Function
Malfunction indicator lamp (MIL)		Regarding the arrangement. Refer to MWI-6, "METER SYSTEM : Design" .
		Regarding the function. Refer to EC-57, "WARNING LAMPS/INDICATOR LAMPS : Malfunction Indicator Lamp (MIL)" .

WARNING/INDICATOR/CHIME LIST : Warning/Indicator (On Information Display)

INFOID:000000012274749

Item	Reference
Shift position indicator	Refer to TM-37, "INFORMATION DISPLAY (COMBINATION METER) : Shift Position Indicator" .
Drive mode indicator	Refer to DMS-5, "Drive Mode Indicator" .

ON BOARD DIAGNOSTIC (OBD) SYSTEM

< SYSTEM DESCRIPTION >

[CVT: RE0F10H]

ON BOARD DIAGNOSTIC (OBD) SYSTEM

Description

INFOID:0000000011972894

This is an on board diagnosis system which records diagnosis information related to the exhaust gases. It detects malfunctions related to sensors and actuators. The malfunctions are indicated by means of the malfunction indicator lamp (MIL) and are stored as DTC in the ECU memory. The diagnosis information can be checked using a diagnosis tool (GST: Generic Scan Tool).

Function of OBD

INFOID:0000000011972895

The GST is connected to the diagnosis connector on the vehicle and communicates with the on-board control units to perform diagnosis. The diagnosis connector is the same as for CONSULT. Refer to [GI-49. "Description"](#).

A
B
C
TM
E
F
G
H
I
J
K
L
M
N
O
P

DIAGNOSIS SYSTEM (TCM)

DIAGNOSIS DESCRIPTION

DIAGNOSIS DESCRIPTION : 1 Trip Detection Diagnosis and 2 Trip Detection Diagnosis

INFOID:000000011972896

NOTE:

"Start the engine and turn OFF the ignition switch after warm-up." This is defined as 1 trip.

1 TRIP DETECTION DIAGNOSIS

When initial malfunction is detected, TCM memorizes DTC. In these diagnoses, some illuminate MIL and some do not. Refer to [TM-58. "DTC Index"](#).

2 TRIP DETECTION DIAGNOSIS

When initial malfunction is detected, TCM memorizes DTC of the 1st trip. MIL does not light at this stage. <1 trip>

If the same malfunction is detected again in next driving, TCM memorizes DTC. When DTC is memorized, MIL lights. <2 trip>

"Trip" of the "2 trip detection diagnosis" indicates the driving mode that executes self-diagnosis during driving.
x: Check possible —: Check not possible

Item	DTC at the 1st trip		DTC		MIL	
	Display at the 1st trip	Display at the 2nd trip	Display at the 1st trip	Display at the 2nd trip	Illumination at the 1st trip	Illumination at the 2nd trip
1 trip detection diagnosis (Refer to TM-58. "DTC Index")	—	—	x	—	x	—
2 trip detection diagnosis (Refer to TM-58. "DTC Index")	x	—	—	x	—	x

DIAGNOSIS DESCRIPTION : DTC and DTC of 1st Trip

INFOID:000000011972897

2 TRIP DETECTION DIAGNOSIS THAT ILLUMINATES MIL

- The DTC number of the 1st trip is the same as the DTC number.
- When a malfunction is detected at the 1st trip, TCM memorizes DTC of the 1st trip. MIL does not light at this stage. If the same malfunction is not detected at the 2nd trip (conforming to necessary driving conditions), DTC at the 1st trip is erased from TCM. If the same malfunction is detected at the 2nd trip, TCM memorizes DTC and MIL lights at the same time.
- The DTC of the 1st trip is specified in Service \$01 of SAE J1979/ISO 15031-5. Since detection of DTC at the 1st trip does not illuminate MIL, warning for a problem is not given to a driver.
- For procedure to delete DTC and 1st trip DTC from TCM, refer to [TM-42. "CONSULT Function"](#).
- If DTC of the 1st trip is detected, it is necessary to check the cause according to the "Diagnosis flow". Refer to [TM-73. "Work Flow"](#).

DIAGNOSIS DESCRIPTION : Malfunction Indicator Lamp (MIL)

INFOID:000000011972898

- TCM not only detects DTC, but also sends the MIL signal to ECM through CAN communication. ECM sends the MIL signal to the combination meter through CAN communication according to the signal, and illuminates MIL.
- For malfunction indicator lamp (MIL) description, refer to [EC-57. "WARNING LAMPS/INDICATOR LAMPS : Malfunction Indicator Lamp \(MIL\)"](#).

DIAGNOSIS DESCRIPTION : Counter System

INFOID:000000011972899

RELATION BETWEEN DTC AT 1ST TRIP/DTC/MIL AND DRIVING CONDITIONS (FOR 2 TRIP DETECTION DIAGNOSIS THAT ILLUMINATES MIL)

- When initial malfunction is detected, TCM memorizes DTC of the 1st trip. MIL does not light at this stage.
- If the same malfunction is detected at the 2nd trip, TCM memorizes DTC and MIL lights at the same time.
- Then, MIL goes after driving the vehicle for 3 trips under "Driving condition B" without malfunction.
- DTC is displayed until 40 trips of "Driving condition A" are satisfied without detecting the same malfunction. DTC is erased when 40 trips are satisfied.

DIAGNOSIS SYSTEM (TCM)

[CVT: RE0F10H]

< SYSTEM DESCRIPTION >

- When the self-diagnosis result is acceptable at the 2nd trip (conforming to driving condition B), DTC of the 1st trip is erased.

COUNTER SYSTEM LIST

Item	Driving condition	Trip
MIL (OFF)	B	3
DTC (clear)	A	40
DTC at 1st trip (clear)	B	1

DRIVING CONDITION

Driving condition A

Driving condition A is the driving condition that provides warm-up.

In specific, count-up is performed when all of the following conditions are satisfied.

- Engine speed is 400 rpm or more.
- After start of the engine, the water temperature increased by 20°C (36°F) or more.
- Water temperature was 70°C (158°F) or more.
- The ignition switch was changed from ON to OFF.

NOTE:

- If the same malfunction is detected regardless of the driving condition, reset the A counter.
- When the above is satisfied without detecting the same malfunction, count up the A counter.
- When MIL goes off due to the malfunction and the A counter reaches 40, the DTC is erased.

Driving condition B

Driving condition B is the driving condition that performs all diagnoses once.

In specific, count-up is performed when all of the following conditions are satisfied.

- Engine speed is 400 rpm or more.
- Water temperature was 70°C (158°F) or more.
- In closed loop control, vehicle speed of 70 – 120 km/h (43 – 75 MPH) continued for 60 seconds or more.
- In closed loop control, vehicle speed of 30 – 60 km/h (19 – 37 MPH) continued for 10 seconds or more.
- In closed loop control, vehicle speed of 4 km/h (2 MPH) or less and idle determination ON continued for 12 seconds or more.
- After start of the engine, 22 minutes or more have passed.
- The condition that the vehicle speed is 10 km/h (6 MPH) or more continued for 10 seconds or more in total.
- The ignition switch was changed from ON to OFF.

NOTE:

- If the same malfunction is detected regardless of the driving condition, reset the B counter.
- When the above is satisfied without detecting the same malfunction, count up the B counter.
- When the B counter reaches 3 without malfunction, MIL goes off.
- When the B counter is counted once without detecting the same malfunction after TCM memorizes DTC of the 1st trip, DTC of the 1st trip is erased.

DIAGNOSIS SYSTEM (TCM)

< SYSTEM DESCRIPTION >

[CVT: RE0F10H]

TIME CHART

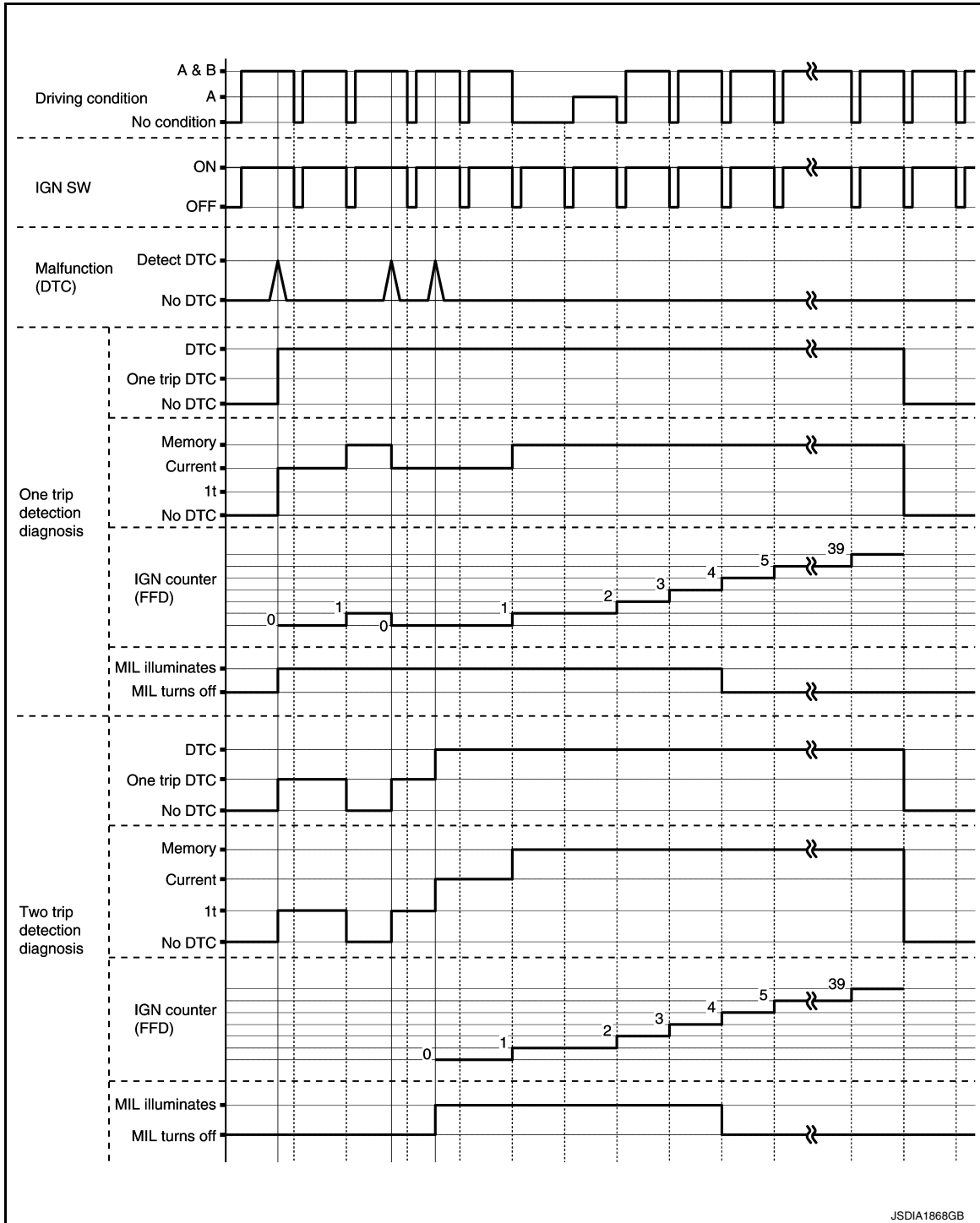

JSDIA1868GB

CONSULT Function

INFOID:000000011972900

CAUTION:

After disconnecting the CONSULT vehicle interface (VI) from the data link connector, the ignition must be cycled OFF → ON (for at least 5 seconds) → OFF. If this step is not performed, the BCM may not go to "sleep mode", potentially causing a discharged battery and a no-start condition.

APPLICABLE ITEM

DIAGNOSIS SYSTEM (TCM)

< SYSTEM DESCRIPTION >

[CVT: RE0F10H]

Conditions	Function
Work Support	The settings for ECU functions can be changed.
Self Diagnostic Results	The ECU self diagnostic results are displayed.
Data Monitor	The ECU input/output data is displayed in real time.
CAN Diagnosis Support Monitor	The result of transmit/receive diagnosis of CAN communication is displayed.
Active Test	The ECU activates outputs to test components.
ECU Identification	The ECU part number is displayed.
CALIB DATA	The calibration data status of TCM can be checked.

SELF DIAGNOSTIC RESULTS

Display Item List

Refer to [TM-58, "DTC Index"](#).

DTC at 1st trip and method to read DTC

- DTC is specified by SAE J2012/ISO 15031-6.
- DTC and DTC at 1st trip are displayed on "Self Diagnostic results" of CONSULT.
When DTC is currently detected, "CRNT" is displayed. If "PAST" is displayed, it shows a malfunction occurred in the past. The trip number of drive without malfunction of concerned DTC can be confirmed with "IGN counter" inside "FFD".
- When the DTC at the 1st trip is detected, "1t" is displayed.

DTC deletion method

NOTE:

If the ignition switch is left ON after repair, turn OFF the ignition switch and wait for 10 seconds or more. Then, turn the ignition ON again. (Engine stop)

1. Touch "TRANSMISSION" of CONSULT.
2. Touch "Self Diagnostic Result".
3. Touch "Erase". (DTC memorized in TCM is erased.)

Freeze Frame Data (FFD)

The following vehicle status is recorded when DTC is detected and is displayed on CONSULT.

Item name	Display content
ODOMETER (km or mile)	Total driving distance (odometer value) upon DTC detection is displayed.
IGN counter (039)	<p>The ignition counter is displayed in "FFD" and the number of times of satisfied "Driving condition A" is displayed after normal recovery of DTC. Refer to TM-40, "DIAGNOSIS DESCRIPTION : Counter System". Numerical value is displayed indicating the number of times that ignition switch is turned ON after the DTC is detected.</p> <ul style="list-style-type: none"> • If malfunction (DTC) is currently detected, "0" is displayed. • After normal recovery, every time "Driving condition A" is satisfied, the display value increases from 1 → 2 → 3...38 → 39. • When MIL turns OFF due to the malfunction and the counter reaches 40, the DTC is erased. <p>NOTE: The counter display of "40" cannot be checked.</p>

DATA MONITOR

NOTE:

The following table includes information (items) inapplicable to this vehicle. For information (items) applicable to this vehicle, refer to CONSULT display items.

Monitored item	(Unit)	Remarks
VSP SENSOR	(km/h or mph)	Displays the vehicle speed calculated from the CVT output shaft speed.
ESTM VSP SIG	(km/h or mph)	Displays the vehicle speed signal (ABS) received through CAN communication.
INPUT SPEED SENSOR	(rpm)	Displays the input speed calculated from the pulse signal of the input speed sensor.

DIAGNOSIS SYSTEM (TCM)

< SYSTEM DESCRIPTION >

[CVT: RE0F10H]

Monitored item	(Unit)	Remarks
PRI SPEED SEN	(rpm)	Displays the primary pulley speed calculated from the pulse signal of the primary speed sensor.
SEC REV SENSOR	(rpm)	Displays the secondary pulley speed calculated from the pulse signal of the output speed sensor.
ENG SPEED SIG	(rpm)	Displays the engine speed received through CAN communication.
SEC PRESSURE SEN	(V)	Displays the signal voltage of the secondary pressuresensor.
PRI PRESSURE SEN	(V)	Displays the signal voltage of the primary pressuresensor.
ATF TEMP SEN	(V)	Displays the signal voltage of the CVT fluid temperature sensor.
G SENSOR*	(G)	Displays the signal voltage of the G sensor.
VIGN SEN	(V)	Displays the battery voltage applied to TCM.
PVING VOLT	(V)	Displays the backup voltage of TCM.
VEHICLE SPEED	(km/h or mph)	Displays the vehicle speed recognized by TCM.
INPUT REV	(rpm)	Displays the input shaft speed of CVT recognized by TCM.
PRI SPEED	(rpm)	Displays the primary pulley speed recognized by TCM.
SEC SPEED	(rpm)	Displays the secondary pulley speed recognized by TCM.
ENG SPEED	(rpm)	Displays the engine speed recognized by TCM.
SLIP REV	(rpm)	Displays the speed difference between the input shaft speed of CVT and the engine speed.
PULLEY GEAR RATIO		Displays the pulley gear ratio calculated from primary pulley speed/secondary pulley speed.
G SPEED*	(G)	Displays the acceleration and deceleration speed of the vehicle calculated from vehicle speed change.
ACCEL POSI SEN 1	(deg)	Displays the estimated throttle position received through CAN communication.
VENG TRQ	(Nm)	Display the engine torque recognized by TCM.
PRI TRQ	(Nm)	Display the input shaft torque of CVT.
TRQ RTO		Display the torque ratio of torque converter.
SEC PRESSURE	(MPa, kg/cm ² or psi)	Displays the secondary pressure calculated from the signal voltage of the secondary pressure sensor.
PRI PRESSURE	(MPa, kg/cm ² or psi)	Displays the primary pressure calculated from the signal voltage of the primary pressure sensor.
FLUID TEMP	(°C or °F)	Displays the CVT fluid temperature calculated from the signal voltage of the CVT fluid temperature sensor.
DSR REV	(rpm)	Displays the target primary pulley speed calculated from processing of gear shift control.
TGT PLY GR RATIO		Displays the target gear ratio of the pulley from processing of gear shift control.
LU PRS	(MPa, kg/cm ² or psi)	Displays the target oil pressure of the torque converter clutch solenoid valve calculated from oil pressure processing of lock-up control.
LINE PRS	(MPa, kg/cm ² or psi)	Displays the target oil pressure of the line pressure solenoid valve calculated from oil pressure processing of gear shift control.
TRGT PRI PRESSURE	(MPa, kg/cm ² or psi)	Displays the target oil pressure of the primary pressure solenoid valve calculated from oil pressure processing of gear shift control.
TRGT SELECT PRESSURE	(MPa, kg/cm ² or psi)	Displays the target oil pressure of the select solenoid valve calculated from oil pressure processing of gear shift control.
TRGT SEC PRESSURE	(MPa, kg/cm ² or psi)	Displays the target oil pressure of the secondary pressure solenoid valve calculated from oil pressure processing of gear shift control.
ISOLT1	(A)	Displays the command current from TCM to the torque converter clutch solenoid valve.
ISOLT2	(A)	Displays the command current from TCM to the line pressure solenoid valve.

DIAGNOSIS SYSTEM (TCM)

< SYSTEM DESCRIPTION >

[CVT: RE0F10H]

Monitored item	(Unit)	Remarks
PRI SOLENOID	(A)	Displays the command current from TCM to the primary pressure solenoid valve.
SEC SOLENOID CURRENT	(A)	Displays the command current from TCM to the secondary pressure solenoid valve.
SELECT SOLENOID CURRENT	(A)	Displays the command current from TCM to the select solenoid valve.
SOLMON1	(A)	Monitors the command current from TCM to the torque converter clutch solenoid valve and displays the monitored value.
SOLMON2	(A)	Monitors the command current from TCM to the line pressure solenoid valve and displays the monitored value.
PRI SOL MON	(A)	Monitors the command current from TCM to the primary pressure solenoid valve and displays the monitored value.
SEC SOL MON CURRENT	(A)	Monitors the command current from TCM to the secondary pressure solenoid valve and displays the monitored value.
SELECT SOL MON CURRENT	(A)	Monitors the command current from TCM to the select solenoid valve and displays the monitored value.
D POSITION SW	(On/Off)	Displays the operation status of the transmission range switch (D position).
N POSITION SW	(On/Off)	Displays the operation status of the transmission range switch (N position).
R POSITION SW	(On/Off)	Displays the operation status of the transmission range switch (R position).
P POSITION SW	(On/Off)	Displays the operation status of the transmission range switch (P position).
L POSITION SW*	(On/Off)	Displays the operation status of the transmission range switch (L position).
BRAKESW	(On/Off)	Displays the reception status of the stop lamp switch signal received through CAN communication.
IDLE SW	(On/Off)	Displays the reception status of the closed throttle position signal received through CAN communication.
SPORT MODE SW*	(On/Off)	Displays the reception status of the over drive control switch signal received through CAN communication.
STRDWNSW	(On/Off)	Displays the operation status of the paddle shifter (down switch).
STRUPSW	(On/Off)	Displays the operation status of the paddle shifter (up switch).
DOWNLVR	(On/Off)	Displays the operation status of the selector lever (down switch).
UPLVR	(On/Off)	Displays the operation status of the selector lever (up switch).
NONMMODE	(On/Off)	Displays if the selector lever position is not at the manual shift gate.
MMODE	(On/Off)	Displays if the selector lever position is at the manual shift gate.
SHIFT IND SIGNAL		Displays the transaxle value of shift position signal transmitted via CAN communication.
CVT LAMP*	(On/Off)	Displays the transaxle status of the CVT warning lamp signal transmitted through CAN communication.
SPORT MODE IND*	(On/Off)	Displays the transaxle status of the O/D OFF indicator lamp signal transmitted through CAN communication.
MANU MODE SIGNAL	(On/Off)	Displays the transaxle status of the manual mode signal transmitted through CAN communication.
VDC ON	(On/Off)	Displays the reception status of the VDC operation signal received through CAN communication.
TCS ON	(On/Off)	Displays the reception status of the TCS operation signal received through CAN communication.
ABS FAIL SIGNAL	(On/Off)	Displays the reception status of the ABS malfunction signal received through CAN communication.
ABS ON	(On/Off)	Displays the reception status of the ABS operation signal received through CAN communication.
RANGE		Displays the gear position recognized by TCM.
M GEAR POS		Display the target gear of manual mode

A
B
C
TM
E
F
G
H
I
J
K
L
M
N
O
P

DIAGNOSIS SYSTEM (TCM)

[CVT: RE0F10H]

< SYSTEM DESCRIPTION >

Monitored item	(Unit)	Remarks
G SEN SLOPE*	(%)	Displays the gradient angle calculated from the G sensor signal voltage.
G SEN CALIBRATION*	(YET/DONE)	Displays the status of "G SENSOR CALIBRATION" in "Work Support".
N IDLE STATUS*	(On/Off)	Displays idle neutral status.
ENGBRKLVL	(On/Off)	Displays the setting of "ENGINE BRAKE ADJ" in "Work Support".
DRIVE MODE STATS		Displays the drive mode status recognized by TCM.
SNOW MODE*	(On/Off)	Displays whether it is the SNOW mode.
ECO MODE*	(On/Off)	Displays whether it is the ECO mode.
NORMAL MODE	(On/Off)	Displays whether it is the NORMAL mode.
SPORT MODE	(On/Off)	Displays whether it is the SPORT mode.
CVT-B		<ul style="list-style-type: none"> Displays CVT fluid temperature count. This monitor item does not use.
CVT-A		<ul style="list-style-type: none"> Displays CVT fluid temperature count. This monitor item does not use.
AXLE TYPE	(2WD/4WD)	Displays axle type.

*: Not applicable but displayed.

WORK SUPPORT

Item name	Description
CONFORM CVTF DETERIORTN	Checks the degradation level of the CVT fluid under severe conditions.
G SENSOR CALIBRATION*	Compensates the G sensor.
ERASE LEARNING VALUE*	Erases learning value memorized by TCM.
ENGINE BRAKE ADJ.	Although there is no malfunction on the transaxle and the CVT system, if a customer makes a complaint like "I do not feel comfortable with automatic operation of the engine brake on downhill", the engine brake can be cancelled by "engine brake adjustment".
FWD CLUTCH POINT LEARNING*	Allows TCM to learn clutch engagement point.
WRITE IP CHARA - REPLACEMENT AT/CVT	Writes IP characteristics when transaxle assembly is replaced.
READ IP CHARA - REPLACEMENT TCM	Reads IP characteristics when TCM is replaced.
WRITE IP CHARA - REPLACEMENT TCM	Writes IP characteristics when TCM is replaced.

*: This item is not used.

Check the degradation level of the CVT fluid.

CVTF degradation level data

210,000 or more : Replacement of the CVT fluid is required.

Less than 210,000 : Replacement of the CVT fluid is not required.

Engine brake adjustment

ENGINE BRAKE LEVEL

ON : Turn ON the engine brake control.

OFF : Turn OFF the engine brake control.

ACTIVE TEST

Item name	Description
CVT OIL COOLER FAN CIRCUIT*	Checks the operation of CVT oil cooler fan relay.

*: This item does not use.

ECU DIAGNOSIS INFORMATION

TCM

Reference Value

INFOID:0000000011972901

CONSULT DATA MONITOR STANDARD VALUE

- In CONSULT, electric shift timing or lock-up timing, i.e. operation timing of each solenoid valve, is displayed. Therefore, if there is an obvious difference between the shift timing estimated from a shift shock (or engine speed variations) and that shown on the CONSULT, the mechanism parts (including the hydraulic circuit) excluding the solenoids and sensors may be malfunctioning. In this case, check the mechanical parts following the appropriate diagnosis procedure.
- Shift point (gear position) displayed on CONSULT slightly differs from shift pattern described in Service Manual. This is due to the following reasons.
 - Actual shift pattern may vary slightly within specified tolerances.
 - While shift pattern described in Service Manual indicates start of each shift, CONSULT shows gear position at end of shift.
 - The solenoid display (ON/OFF) on CONSULT is changed at the start of gear shifting. In contrast, the gear position display is changed at the time when gear shifting calculated in the control unit is completed.

NOTE:

The following table includes information (items) inapplicable to this vehicle. For information (items) applicable to this vehicle, refer to CONSULT display items.

Monitor item	Condition	Value/Status (Approx.)
VSP SENSOR	While driving	Almost same as the speedometer display.
ESTM VSP SIG	While driving	Almost same as the speedometer display.
INPUT SPEED SENSOR	In driving (lock-up ON)	Approximately matches the engine speed.
PRI SPEED SEN	In driving (lock-up ON)	Approximately matches the engine speed.
SEC REV SENSOR	While driving	VSP SENSOR × 38 rpm
ENG SPEED SIG	Engine running	Almost same reading as tachometer
SEC PRESSURE SEN	<ul style="list-style-type: none"> • After engine warm up • Selector lever: "N" position • At idle 	1.2 – 1.3 V
PRI PRESSURE SEN	<ul style="list-style-type: none"> • After engine warm up • Selector lever: "N" position • At idle 	0.9 V
ATF TEMP SEN	CVT fluid: Approx. 20°C (68°F)	2.0 – 2.1 V
	CVT fluid: Approx. 50°C (122°F)	1.4 – 1.5 V
	CVT fluid: Approx. 80°C (176°F)	0.9 – 1.0 V
G SENSOR	<ul style="list-style-type: none"> • Vehicle stopped • Vehicle is level 	0 G
	During acceleration	The value changes to the positive side along with acceleration.
	During deceleration	The value changes to the positive side along with deceleration.
VIGN SEN	Ignition switch: ON	10 – 16 V
PVING VOLT	Ignition switch: ON	10 – 16 V
VEHICLE SPEED	While driving	Almost same as the speedometer display.
INPUT REV	In driving (lock-up ON)	Almost same as the engine speed.
PRI SPEED	In driving (lock-up ON)	Approximately matches the engine speed.
SEC SPEED	While driving	VSP SENSOR × 38
ENG SPEED	Engine running	Almost same reading as tachometer
SLIP REV	While driving	Engine speed – Input speed

TCM

< ECU DIAGNOSIS INFORMATION >

[CVT: RE0F10H]

Monitor item	Condition	Value/Status (Approx.)
PULLEY GEAR RATIO	In driving (forward)	2.4360 – 0.3840
	In driving (reverse)	2.4360
G SPEED	Vehicle stopped	0.00 G
	During acceleration	The value changes to the positive side along with acceleration.
	During deceleration	The value changes to the positive side along with deceleration.
ACCEL POSI SEN 1	Accelerator pedal released	0.00 deg
	Accelerator pedal fully depressed	80.00 deg
VENG TRQ	While driving	The value changes along with acceleration/ deceleration.
PRI TRQ	While driving	The value changes along with acceleration/ deceleration.
TRQ RTO	While driving	The value changes along with acceleration/ deceleration.
SEC PRESSURE	<ul style="list-style-type: none"> • After engine warm up • Selector lever: "N" position • At idle 	1.1 MPa
PRI PRESSURE	<ul style="list-style-type: none"> • After engine warm up • Selector lever: "N" position • At idle 	0.7 MPa
FLUID TEMP	Ignition switch ON.	Displays the CVT fluid temperature.
DSR REV	While driving	It varies along with the driving condition.
TGT PLY GR RATIO	In driving (forward)	2.4360 – 0.3840
	In driving (reverse)	2.4360
LU PRS	<ul style="list-style-type: none"> • Engine started • Vehicle is stopped 	-0.50 MPa
	<ul style="list-style-type: none"> • Selector lever: "D" position • Accelerator pedal position: 1/8 or less • Vehicle speed: 20 km/h (12 MPH) or more 	0.65 MPa
LINE PRS	<ul style="list-style-type: none"> • After engine warm up • Selector lever: "N" position • At idle 	1.1 MPa
TRGT PRI PRESSURE	<ul style="list-style-type: none"> • After engine warm up • Selector lever: "N" position • At idle 	0.7 MPa
TRGT SELECT PRESSURE	<ul style="list-style-type: none"> • After engine warm up • Selector lever: "N" position • At idle 	0 MPa
	<ul style="list-style-type: none"> • Selector lever: "D" position • At idle 	0.3 – 0.5 MPa
TRGT SEC PRESSURE	<ul style="list-style-type: none"> • After engine warm up • Selector lever: "N" position • At idle 	1.1 MPa
ISOLT1*	—	—
ISOLT2*	—	—
PRI SOLENOID*	—	—
SEC SOLENOID CURRENT*	—	—
SELECT SOLENOID CURRENT*	—	—
SOLMON1*	—	—

TCM

< ECU DIAGNOSIS INFORMATION >

[CVT: RE0F10H]

Monitor item	Condition	Value/Status (Approx.)	
SOLMON2*	—	—	A
PRI SOL MON*	—	—	
SEC SOL MON CURRENT*	—	—	B
SELECT SOL MON CURRENT*	—	—	
D POSITION SW	Selector lever: "D" position	On	C
	Other than the above	Off	
N POSITION SW	Selector lever: "N" position	On	TM
	Other than the above	Off	
R POSITION SW	Selector lever: "R" position	On	E
	Other than the above	Off	
P POSITION SW	Selector lever: "P" position	On	F
	Other than the above	Off	
L POSITION SW	Always	Off	G
BRAKESW	Brake pedal is depressed	On	H
	Brake pedal is released	Off	
IDLE SW	Accelerator pedal is fully depressed	On	I
	Accelerator pedal is released	Off	
SPORT MODE SW	Overdrive control switch: ON	On	J
	Overdrive control switch: OFF	Off	
STRDWNSW	Paddle shifter (shift-down) is pulled	On	K
	Other than the above	Off	
STRUPSW	Paddle shifter (shift-up) is pulled	On	L
	Other than the above	Off	
DOWNLVR	Selector lever: "-" side	On	M
	Other than the above	Off	
UPLVR	Selector lever: "+" side	On	N
	Other than the above	Off	
NONMMODE	Driving with manual mode	Off	O
	Other than the above	On	
MMODE	Driving with manual mode	On	P
	Other than the above	Off	
SHIFT IND SIGNAL	When the selector lever is positioned in between each position.	OFF	
	Selector lever: P position	P	
	Selector lever: R position	R	
	Selector lever: N position	N	
	Selector lever: D position	D	
	Manual mode: 1st	1st	
	Manual mode: 2nd	2nd	
	Manual mode: 3rd	3rd	
	Manual mode: 4th	4th	
	Manual mode: 5th	5th	
Manual mode: 6th	6th		
Manual mode: 7th	7th		
CVT LAMP	Always	Off	

TCM

< ECU DIAGNOSIS INFORMATION >

[CVT: RE0F10H]

Monitor item	Condition	Value/Status (Approx.)
SPORT MODE IND	Overdrive control switch: ON	On
	Overdrive control switch: OFF	Off
MANU MODE SIGNAL	Driving with manual mode	On
	Other than the above	Off
VDC ON	When VDC malfunction signal is received	On
	Other than the above	Off
TCS ON	When TCS malfunction signal is received	On
	Other than the above	Off
ABS FAIL SIGNAL	When ABS malfunction signal is received	On
	Other than the above	Off
ABS ON	ABS is activated	On
	Other than the above	Off
RANGE	Selector lever: P and N positions	N/P
	Selector lever: R position	R
	Selector lever: D position	D
M GEAR POS	Manual mode: 1st – 7th	1 to 7
G SEN SLOPE	Flat load	0%
	Uphill gradient	The value changes to the positive side along with uphill gradient. (Maximum 40.45%)
	Downhill gradient	The value changes to the negative side along with downhill gradient. (Minimum 40.45%)
G SEN CALIBRATION	Always	DONE
N IDLE STATUS	Always	Off
ENGBRKLVL	When the engine brake level of "ENGINE BRAKE ADJ". in "Work Support" is ON	On
	When the engine brake level of "ENGINE BRAKE ADJ". in "Work Support" is OFF	Off
DRIVE MODE STATS	Drive mode: SPORT	SPORT
	Drive mode: Normal	NOMAL
SNOW MODE	Always	Off
ECO MODE	Always	Off
NORMAL MODE	Drive mode: Normal	On
	Drive mode: SPORT	Off
SPORT MODE	Drive mode: SPORT	On
	Drive mode: Normal	Off
CVT-B*	—	—
CVT-A*	—	—
AXLE TYPE	Always	2WD

*: These monitor items do not use.

TERMINAL LAYOUT

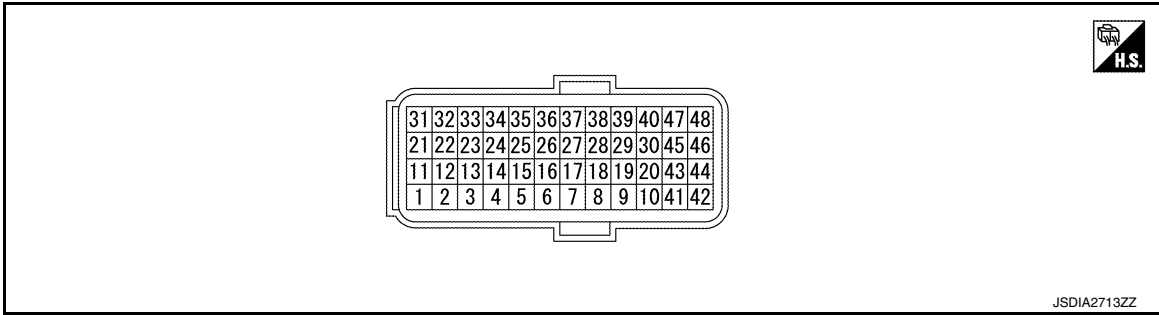

INPUT/OUTPUT SIGNAL STANDARD

Terminal No. (Wire color)		Description		Condition		Value (Approx.)
+	-	Signal	Input/ Output			
4 (LG)	Ground	D position switch	Input	Ignition switch ON	Selector lever: "D" position	10 – 16 V
					Other than the above	0 V
5 (BR)	Ground	N position switch	Input	Ignition switch ON	Selector lever: "N" position	10 – 16 V
					Other than the above	0 V
6 (L)	Ground	R position switch	Input	Ignition switch ON	Selector lever: "R" position	10 – 16 V
					Other than the above	0 V
7 (V)	Ground	P position switch	Input	Ignition switch ON	Selector lever: "P" position	10 – 16 V
					Other than the above	0 V
11 (L)	Ground	Sensor ground	Input	Always		0 V
12 (V)	Ground	CVT fluid temperature sensor	Input	Ignition switch ON	CVT fluid: Approx. 20°C (68°F)	2.01 – 2.05 V
					CVT fluid: Approx. 50°C (122°F)	1.45 – 1.50 V
					CVT fluid: Approx. 80°C (176°F)	0.90 – 0.94 V
16 (Y)	Ground	Secondary pressure sensor	Input	<ul style="list-style-type: none"> Selector lever: "N" position At idle 		1.2 – 1.3 V
17 (LG)	Ground	Primary pressure sensor	Input	<ul style="list-style-type: none"> Selector lever: "N" position At idle 		0.9 V
23 (P)	—	CAN-L	Input/ Output	—		—
24 (BR)	Ground	Input speed sensor	Input	<ul style="list-style-type: none"> Selector lever: "M1" position Vehicle speed: 20 km/h (12 MPH) 		<p>800 Hz 1mSec/div</p> <p>5V/div JSDIA3770GB</p>
26 (LG)	Ground	Sensor power supply	Output	Ignition switch: ON		5.0 V
				Ignition switch: OFF		0 V

TCM

< ECU DIAGNOSIS INFORMATION >

[CVT: RE0F10H]

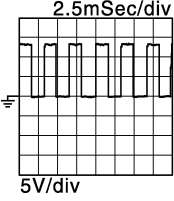
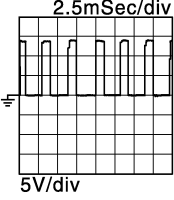
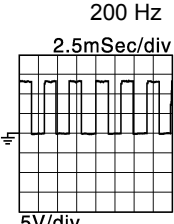
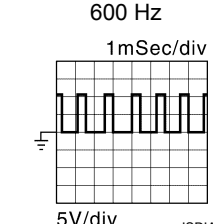
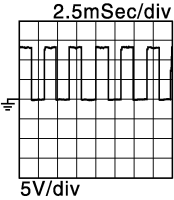
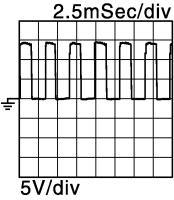
Terminal No. (Wire color)		Description		Condition	Value (Approx.)
+	-	Signal	Input/ Output		
30 (BR)	Ground	Line pressure solenoid valve	Output	<ul style="list-style-type: none"> After engine warming up Selector lever: "N" position At idle 	 <p style="text-align: right; font-size: small;">JSDIA1897GB</p>
				<ul style="list-style-type: none"> After engine warming up Selector lever: "N" position Depress the accelerator pedal fully 	 <p style="text-align: right; font-size: small;">JSDIA1898GB</p>
33 (L)	—	CAN-H	Input/ Output	—	—
34 (SB)	Ground	Output speed sensor	Input	<ul style="list-style-type: none"> Selector lever: "M1" position Vehicle speed: 20 km/h (12 MPH) 	 <p style="text-align: right; font-size: small;">JSDIA1897GB</p>
35 (BR)	Ground	Primary speed sensor	Input	<ul style="list-style-type: none"> Selector lever: "M1" position Vehicle speed: 20 km/h (12 MPH) 	 <p style="text-align: right; font-size: small;">JSDIA3770GB</p>
37 (Y)	Ground	Select solenoid valve	Output	In driving at "M1" position	 <p style="text-align: right; font-size: small;">JSDIA1897GB</p>
				Release the accelerator pedal after the following conditions are satisfied <ul style="list-style-type: none"> Selector lever: "D" position Accelerator pedal position: 1/8 or less Vehicle speed: 50 km/h (31 MPH) or more 	 <p style="text-align: right; font-size: small;">JSDIA1899GB</p>

TCM

< ECU DIAGNOSIS INFORMATION >

[CVT: RE0F10H]

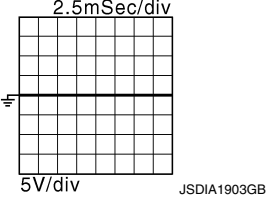
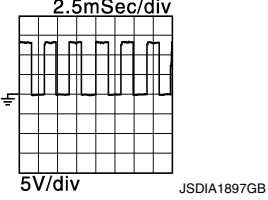
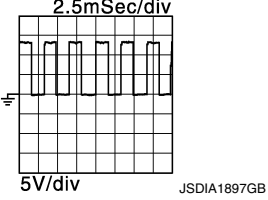
Terminal No. (Wire color)		Description		Condition	Value (Approx.)
+	-	Signal	Input/ Output		
38 (V)	Ground	Torque converter clutch solenoid valve	Output	<ul style="list-style-type: none"> Selector lever: "D" position Accelerator pedal position: 1/8 or less Vehicle speed: 20 km/h (12 MPH) or more 	
				<ul style="list-style-type: none"> Engine started Vehicle is stopped 	
39 (L)	Ground	Secondary pressure solenoid valve	Output	<ul style="list-style-type: none"> Selector lever: "M1" position Vehicle speed: 20 km/h (12 MPH) 	
40 (LG)	Ground	Primary pressure solenoid valve	Output	<ul style="list-style-type: none"> Selector lever: "M1" position Vehicle speed: 20 km/h (12 MPH) 	
41 (B)	Ground	Ground	Output	Always	0 V
42 (B)	Ground	Ground	Output	Always	0 V
45 (P)	Ground	Battery power supply (memory back-up)	Input	Always	10 – 16 V
46 (P)	Ground	Battery power supply (memory back-up)	Input	Always	10 – 16 V
47 (Y)	Ground	Ignition power supply	Input	Ignition switch: ON	10 – 16 V
				Ignition switch: OFF	0 V
48 (Y)	Ground	Ignition power supply	Input	Ignition switch: ON	10 – 16 V
				Ignition switch: OFF	0 V

Fail-safe

INFOID:000000011972902

TCM has a fail-safe mode. The mode functions so that operation can be continued even if the signal circuit of the main electronically controlled input/output parts is damaged.

If the vehicle shows following behaviors including "poor acceleration", a malfunction of the applicable system is detected by TCM and the vehicle may be in a fail-safe mode. At this time, check the DTC code and perform inspection and repair according to the malfunction diagnosis procedures.

Fail-safe function

DTC	Vehicle behavior	Conditions of vehicle
P062F	<ul style="list-style-type: none"> • Not changed from normal driving 	—
P0705	<ul style="list-style-type: none"> • Shift position indicator on combination meter is not displayed • Selector shock is large • Start is slow • Acceleration is slow • Lock-up is not performed 	—
P0706	<ul style="list-style-type: none"> • Shift position indicator on combination meter is not displayed • Selector shock is large • Start is slow • Acceleration is slow • Lock-up is not performed 	—
P0711	<ul style="list-style-type: none"> • Start is slow • Acceleration is slow 	Engine coolant temperature when engine start: Temp. $\geq 10^{\circ}\text{C}$ (50°F)
	<ul style="list-style-type: none"> • Selector shock is large • Start is slow • Acceleration is slow 	Engine coolant temperature when engine start: -35°C (-31°F) \leq Temp. $< 10^{\circ}\text{C}$ (50°F)
	<ul style="list-style-type: none"> • Selector shock is large • Start is slow • Acceleration is slow 	Engine coolant temperature when engine star: Temp. $< -35^{\circ}\text{C}$ (-31°F)
P0712	<ul style="list-style-type: none"> • Start is slow • Acceleration is slow 	Engine coolant temperature when engine start: Temp. $\geq 10^{\circ}\text{C}$ (50°F)
	<ul style="list-style-type: none"> • Selector shock is large • Start is slow • Acceleration is slow 	Engine coolant temperature when engine start: -35°C (-31°F) \leq Temp. $< 10^{\circ}\text{C}$ (50°F)
	<ul style="list-style-type: none"> • Selector shock is large • Start is slow • Acceleration is slow 	Engine coolant temperature when engine star: Temp. $< -35^{\circ}\text{C}$ (-31°F)
P0713	<ul style="list-style-type: none"> • Start is slow • Acceleration is slow 	Engine coolant temperature when engine start: Temp. $\geq 10^{\circ}\text{C}$ (50°F)
	<ul style="list-style-type: none"> • Selector shock is large • Start is slow • Acceleration is slow 	Engine coolant temperature when engine start: -35°C (-31°F) \leq Temp. $< 10^{\circ}\text{C}$ (50°F)
	<ul style="list-style-type: none"> • Selector shock is large • Start is slow • Acceleration is slow 	Engine coolant temperature when engine star: Temp. $< -35^{\circ}\text{C}$ (-31°F)
P0715	<ul style="list-style-type: none"> • Start is slow • Acceleration is slow • Lock-up is not performed • Manual mode is not activated. 	—
P0717	<ul style="list-style-type: none"> • Start is slow • Acceleration is slow • Lock-up is not performed 	—
P0740	<ul style="list-style-type: none"> • Start is slow • Acceleration is slow • Lock-up is not performed 	—
P0743	<ul style="list-style-type: none"> • Start is slow • Acceleration is slow • Lock-up is not performed 	—
P0744	<ul style="list-style-type: none"> • Start is slow • Acceleration is slow • Lock-up is not performed 	—

TCM

< ECU DIAGNOSIS INFORMATION >

[CVT: RE0F10H]

DTC	Vehicle behavior	Conditions of vehicle	
P0746	<ul style="list-style-type: none"> • Selector shock is large • Start is slow • Acceleration is slow • Lock-up is not performed 	—	A
P0776	<ul style="list-style-type: none"> • Selector shock is large • Start is slow • Acceleration is slow • Lock-up is not performed • Vehicle speed is not increased 	When a malfunction occurs on the low oil pressure side	B C
	<ul style="list-style-type: none"> • Selector shock is large • Start is slow • Acceleration is slow • Lock-up is not performed 	When a malfunction occurs on the high oil pressure side	TM
P0778	<ul style="list-style-type: none"> • Selector shock is large • Start is slow • Acceleration is slow • Lock-up is not performed 	—	E
P0779	<ul style="list-style-type: none"> • Selector shock is large • Start is slow • Acceleration is slow • Lock-up is not performed 	—	F G
P0826	Manual mode is not activated.	—	G
P0841	<ul style="list-style-type: none"> • Not changed from normal driving 	—	H
P0847	<ul style="list-style-type: none"> • Not changed from normal driving 	—	H
P0848	<ul style="list-style-type: none"> • Not changed from normal driving 	—	I
P084C	<ul style="list-style-type: none"> • Not changed from normal driving 	—	I
P084D	<ul style="list-style-type: none"> • Not changed from normal driving 	—	I
P0863	<ul style="list-style-type: none"> • Selector shock is large • Start is slow • Acceleration is slow • Lock-up is not performed 	—	J
P0890	<ul style="list-style-type: none"> • Selector shock is large • Start is slow • Acceleration is slow • Lock-up is not performed • Vehicle speed is not increased 	—	K L
P0962	<ul style="list-style-type: none"> • Selector shock is large • Start is slow • Acceleration is slow • Lock-up is not performed 	—	M
P0963	<ul style="list-style-type: none"> • Selector shock is large • Start is slow • Acceleration is slow • Lock-up is not performed 	—	N
P0965	<ul style="list-style-type: none"> • Selector shock is large • Start is slow • Acceleration is slow • Lock-up is not performed 	When a malfunction occurs on the low oil pressure side	O
	<ul style="list-style-type: none"> • Selector shock is large • Lock-up is not performed 	When a malfunction occurs on the high oil pressure side	P
P0966	<ul style="list-style-type: none"> • Selector shock is large • Start is slow • Acceleration is slow • Lock-up is not performed 	—	

TCM

< ECU DIAGNOSIS INFORMATION >

[CVT: RE0F10H]

DTC	Vehicle behavior	Conditions of vehicle
P0967	<ul style="list-style-type: none"> • Selector shock is large • Start is slow • Acceleration is slow • Lock-up is not performed 	—
P2765	<ul style="list-style-type: none"> • Start is slow • Acceleration is slow • Lock-up is not performed • Manual mode is not activated. 	—
P2813	<ul style="list-style-type: none"> • Selector shock is large • Start is slow • Acceleration is slow • Vehicle speed is not increased 	When a malfunction occurs on the low oil pressure side
	<ul style="list-style-type: none"> • Selector shock is large 	When a malfunction occurs on the high oil pressure side
P2814	<ul style="list-style-type: none"> • Selector shock is large 	—
P2815	<ul style="list-style-type: none"> • Selector shock is large 	—
U0073	<ul style="list-style-type: none"> • Selector shock is large • Start is slow • Acceleration is slow • Lock-up is not performed 	—
U0100	<ul style="list-style-type: none"> • Selector shock is large • Start is slow • Acceleration is slow • Lock-up is not performed 	—
U0140	<ul style="list-style-type: none"> • Not changed from normal driving 	—
U0141	<ul style="list-style-type: none"> • Not changed from normal driving 	—
U0155	<ul style="list-style-type: none"> • Not changed from normal driving 	—
U0300	<ul style="list-style-type: none"> • Selector shock is large • Start is slow • Acceleration is slow • Lock-up is not performed 	—
U1000	<ul style="list-style-type: none"> • Not changed from normal driving 	—
U1117	<ul style="list-style-type: none"> • Not changed from normal driving 	—

Protection Control

INFOID:000000011972903

The TCM becomes the protection control status temporarily to protect the safety when the safety of TCM and transmission is lost. It automatically returns to the normal status if the safety is secured.

The TCM has the following protection control.

CONTROL FOR WHEEL SPIN

Control	When a wheel spin is detected, the engine output and gear ratio are limited and the line pressure is increased. Limits engine output when a wheel spin occurs in any of right and left drive wheels.
Vehicle behavior in control	If the accelerator is kept depressing during wheel spin, the engine revolution and vehicle speed are limited to a certain degree.
Normal return condition	Wheel spin convergence returns the control to the normal control.

TORQUE IS REDUCED WHEN DRIVING WITH THE REVERSE GEAR

Control	Engine output is controlled according to a vehicle speed while reversing the vehicle.
Vehicle behavior in control	Power performance may be lowered while reversing the vehicle.
Normal return condition	Torque returns to normal by positioning the selector lever in a range other than "R" position.

CONTROL WHEN FLUID TEMPERATURE IS HIGH

Control	When the CVT fluid temperature is high, the gear shift permission maximum revolution and the maximum torque are reduced than usual to prevent increase of the oil temperature.
Vehicle behavior in control	Power performance may be lowered, compared to normal control.
Normal return condition	The control returns to the normal control when CVT fluid temperature is lowered.

REVERSE PROHIBIT CONTROL

Control	The reverse brake is controlled to avoid becoming engaged when the selector lever is set in "R" position while driving in forward direction at more than the specified speed.
Vehicle behavior in control	If the selector lever is put at "R" position when driving with the forward gear, the gear becomes neutral, not reverse.
Normal return condition	The control returns to normal control when the vehicle is driven at low speeds. (The reverse brake becomes engaged.)

DTC Inspection Priority Chart

INFOID:0000000011972904

If multiple malfunction codes are detected at the same time, check each code according to the DTC check priority list below.

Priority	DTC (Diagnostic Trouble Code)	Reference
1	P0863 CONTROL UNIT (CAN)	TM-151, "DTC Description"
	U0073 COMM BUS A OFF	TM-87, "DTC Description"
	U0100 LOST COMM (ECM A)	TM-88, "DTC Description"
	U0140 LOST COMM (BCM)	TM-89, "DTC Description"
	U0141 LOST COMM (BCM A)	TM-90, "DTC Description"
	U0155 LOST COMM (IPC)	TM-91, "DTC Description"
	U0300 CAN COMM DATA	TM-92, "DTC Description"
	U1000 CAN COMM CIRC	TM-94, "DTC Description"
	U1117 LOST COMM (ABS)	TM-95, "DTC Description"
2	P0740 TORQUE CONVERTER	TM-121, "DTC Description"
	P0743 TORQUE CONVERTER	TM-123, "DTC Description"
	P0778 PC SOLENOID B	TM-131, "DTC Description"
	P0779 PC SOLENOID B	TM-133, "DTC Description"
	P0962 PC SOLENOID A	TM-154, "DTC Description"
	P0963 PC SOLENOID A	TM-156, "DTC Description"
	P0966 PC SOLENOID B	TM-160, "DTC Description"
	P0967 PC SOLENOID B	TM-162, "DTC Description"
	P2814 SELECT SOLENOID	TM-170, "DTC Description"
	P2815 SELECT SOLENOID	TM-172, "DTC Description"

TCM

< ECU DIAGNOSIS INFORMATION >

[CVT: RE0F10H]

Priority	DTC (Diagnostic Trouble Code)	Reference
3	P062F EEPROM	TM-96, "DTC Description"
	P0705 T/M RANGE SENSOR A	TM-98, "DTC Description"
	P0706 T/M RANGE SENSOR A	TM-103, "DTC Description"
	P0711 FLUID TEMP SENSOR A	TM-106, "DTC Description"
	P0712 FLUID TEMP SENSOR A	TM-111, "DTC Description"
	P0713 FLUID TEMP SENSOR A	TM-113, "DTC Description"
	P0715 INPUT SPEED SENSOR A	TM-115, "DTC Description"
	P0717 INPUT SPEED SENSOR A	TM-118, "DTC Description"
	P0826 UP/DOWN SHIFT SWITCH	TM-135, "DTC Description"
	P0841 FLUID PRESS SEN/SW A	TM-141, "DTC Description"
	P0847 FLUID PRESS SEN/SW B	TM-143, "DTC Description"
	P0848 FLUID PRESS SEN/SW B	TM-145, "DTC Description"
	P084C FLUID PRESS SEN/SW H	TM-147, "DTC Description"
	P084D FLUID PRESS SEN/SW H	TM-149, "DTC Description"
	P0890 TCM	TM-152, "DTC Description"
P2765 INPUT SPEED SENSOR B	TM-164, "DTC Description"	
4	P0744 TORQUE CONVERTER	TM-125, "DTC Description"
	P0746 PC SOLENOID A	TM-127, "DTC Description"
	P0776 PC SOLENOID B	TM-129, "DTC Description"
	P0965 PC SOLENOID B	TM-158, "DTC Description"
	P2813 SELECT SOLENOID	TM-168, "DTC Description"

DTC Index

INFOID:0000000011972905

NOTE:

- If multiple malfunction codes are detected at the same time, check each code according to the “DTC check priority list”. Refer to [TM-57, "DTC Inspection Priority Chart"](#).
- The ignition counter is displayed in “FFD”. Refer to [TM-42, "CONSULT Function"](#).

DTC ^{*1, *2}		Items (CONSULT screen terms)	Trip	MIL ^{*3}	Perma- nent DTC group ^{*4}	Reference
GST	CONSULT (TRANSMISSION)					
P062F	P062F	EEPROM	1	ON	B	TM-96
P0705	P0705	T/M RANGE SENSOR A	2	ON	B	TM-98
P0706	P0706	T/M RANGE SENSOR A	2	ON	B	TM-103
P0711	P0711	FLUID TEMP SENSOR A	2	ON	A	TM-106
P0712	P0712	FLUID TEMP SENSOR A	2	ON	B	TM-111
P0713	P0713	FLUID TEMP SENSOR A	2	ON	B	TM-113
P0715	P0715	INPUT SPEED SENSOR A	2	ON	B	TM-115
P0717	P0717	INPUT SPEED SENSOR A	2	ON	B	TM-118
P0740	P0740	TORQUE CONVERTER	2	ON	B	TM-121
P0743	P0743	TORQUE CONVERTER	2	ON	B	TM-123
P0744	P0744	TORQUE CONVERTER	2	ON	B	TM-125
P0746	P0746	PC SOLENOID A	2	ON	B	TM-127
P0776	P0776	PC SOLENOID B	2	ON	B	TM-129
P0778	P0778	PC SOLENOID B	2	ON	B	TM-131
P0779	P0779	PC SOLENOID B	2	ON	B	TM-133

TCM

< ECU DIAGNOSIS INFORMATION >

[CVT: RE0F10H]

DTC*1, *2		Items (CONSULT screen terms)	Trip	MIL*3	Perma- nent DTC group*4	Reference
GST	CONSULT (TRANSMISSION)					
—	P0826	UP/DOWN SHIFT SWITCH	1	—	B	TM-135
P0841	P0841	FLUID PRESS SEN/SW A	2	ON	B	TM-141
P0847	P0847	FLUID PRESS SEN/SW B	2	ON	B	TM-143
P0848	P0848	FLUID PRESS SEN/SW B	2	ON	B	TM-145
P084C	P084C	FLUID PRESS SEN/SW H	2	ON	B	TM-147
P084D	P084D	FLUID PRESS SEN/SW H	2	ON	B	TM-149
P0863	P0863	CONTROL UNIT (CAN)	1	ON	B	TM-151
P0890	P0890	TCM	1	ON	B	TM-152
P0962	P0962	PC SOLENOID A	2	ON	B	TM-154
P0963	P0963	PC SOLENOID A	2	ON	B	TM-156
P0965	P0965	PC SOLENOID B	2	ON	B	TM-158
P0966	P0966	PC SOLENOID B	2	ON	B	TM-160
P0967	P0967	PC SOLENOID B	2	ON	B	TM-162
P2765	P2765	INPUT SPEED SENSOR B	2	ON	B	TM-164
P2813	P2813	SELECT SOLENOID	2	ON	B	TM-168
P2814	P2814	SELECT SOLENOID	2	ON	B	TM-170
P2815	P2815	SELECT SOLENOID	2	ON	B	TM-172
U0073	U0073	COMM BUS A OFF	1	ON	B	TM-87
U0100	U0100	LOST COMM (ECM A)	1	ON	B	TM-88
—	U0140	LOST COMM (BCM)	1	—	—	TM-89
—	U0141	LOST COMM (BCM A)	1	—	—	TM-90
—	U0155	LOST COMM (IPC)	1	—	—	TM-91
—	U0300	CAN COMM DATA	1	—	—	TM-92
—	U1000	CAN COMM CIRC	1	—	—	TM-94
—	U1117	LOST COMM (ABS)	1	—	—	TM-95

*1: These numbers are specified by SAE J2012/ISO 15031-6.

*2: The DTC number of the 1st trip is the same as the DTC number.

*3: Refer to [TM-40, "DIAGNOSIS DESCRIPTION : Malfunction Indicator Lamp \(MIL\)"](#).

*4: Refer to [TM-86, "Description"](#).

CVT CONTROL SYSTEM

< WIRING DIAGRAM >

[CVT: RE0F10H]

WIRING DIAGRAM

CVT CONTROL SYSTEM

Wiring diagram

INFOID:000000011972906

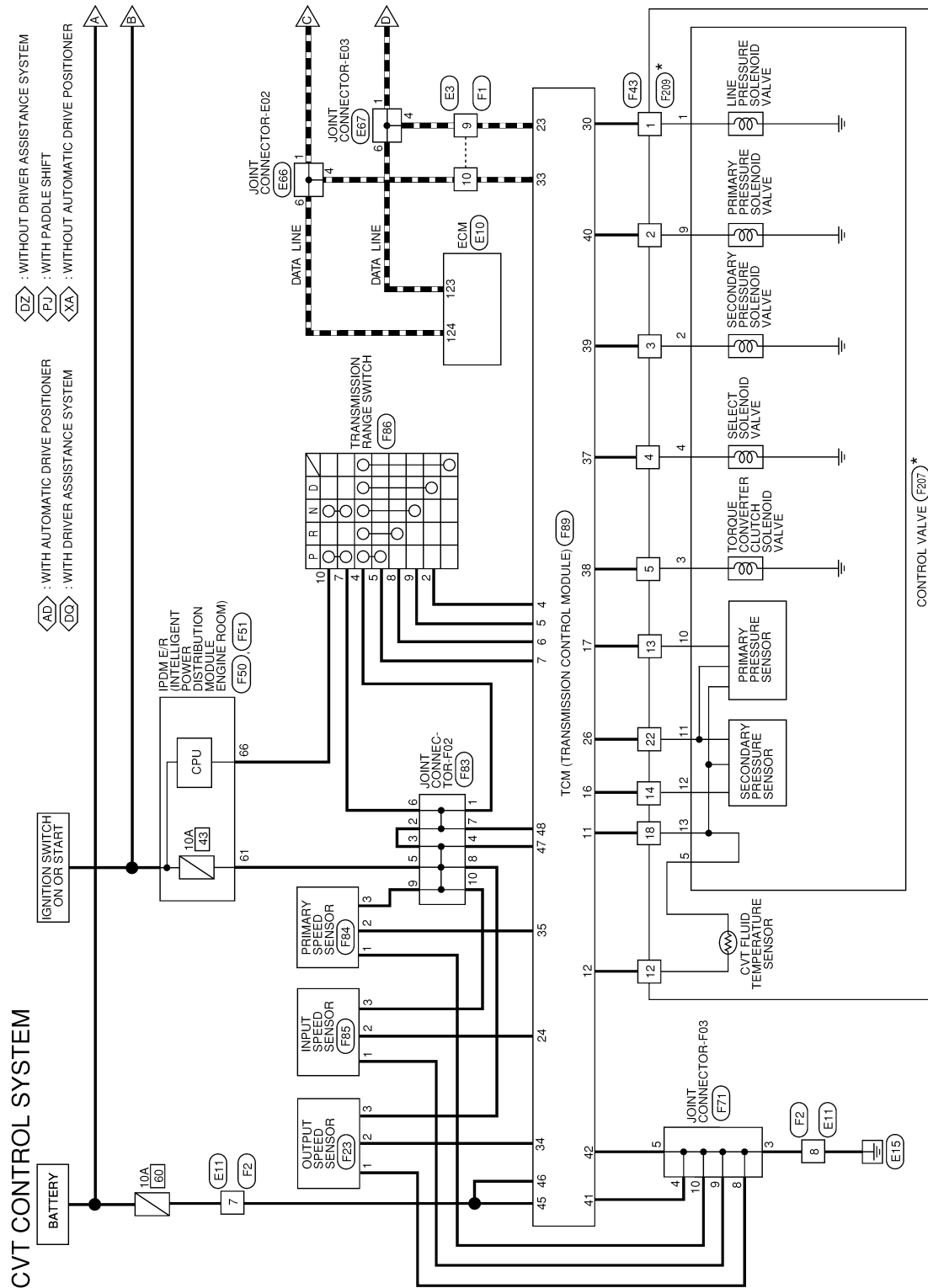

* : THIS CONNECTOR IS NOT SHOWN IN "HARNES LAYOUT" OF PG SECTION.

AADWA0373GB

CVT CONTROL SYSTEM

< WIRING DIAGRAM >

[CVT: RE0F10H]

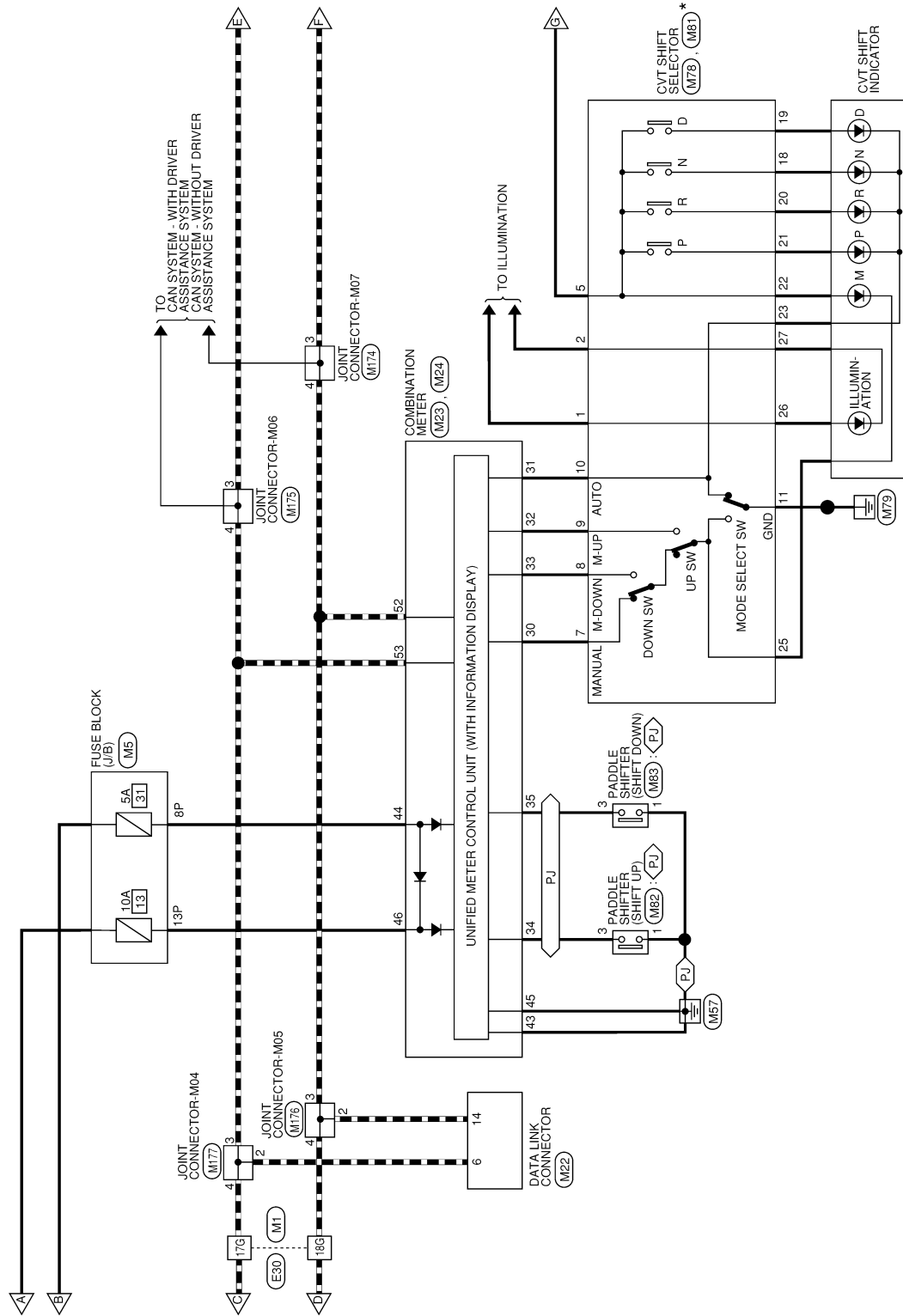

AADWA0374GB

A
B
C
TM
E
F
G
H
I
J
K
L
M
N
O
P

CVT CONTROL SYSTEM

< WIRING DIAGRAM >

[CVT: RE0F10H]

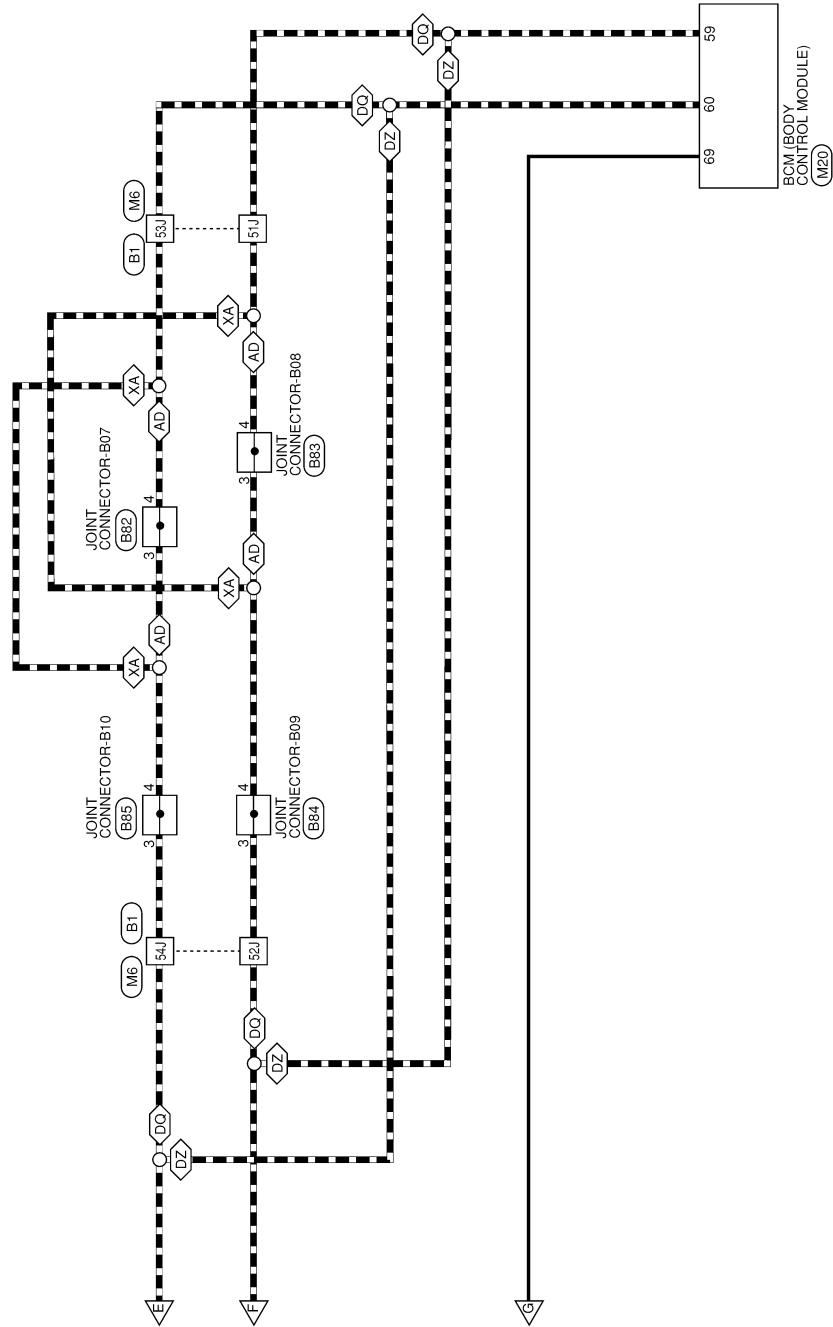

AADWA0375GB

CVT CONTROL SYSTEM CONNECTORS

Connector No.	M1
Connector Name	WIRED TO WIRE
Connector Type	TH80FW-CS16-TM4
Connector Color	WHITE

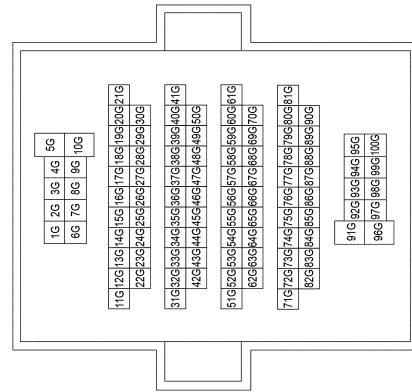

Terminal No.	Color of Wire	Signal Name
17G	L	-
18G	P	-

Connector No.	M5
Connector Name	FUSE BLOCK (J/B)
Connector Type	NS16FW-CS
Connector Color	WHITE



Terminal No.	Color of Wire	Signal Name
8P	BR	-
13P	G	-

Connector No.	M6
Connector Name	WIRED TO WIRE
Connector Type	TH80FDGY-CS16-TM4
Connector Color	GRAY

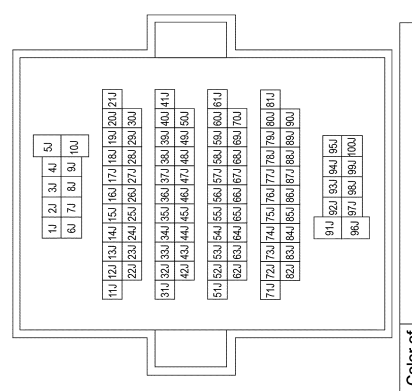

Terminal No.	Color of Wire	Signal Name
51U	P	-
52U	P	-
53U	L	-
54U	L	-

Connector No.	M20
Connector Name	BCM (BODY CONTROL MODULE)
Connector Type	TH40FB-NH
Connector Color	BLACK

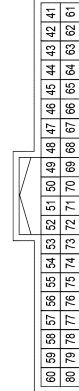

Terminal No.	Color of Wire	Signal Name
59	P	CAN-L
60	L	CAN-H
69	L	AT DEVICE OUT

Connector No.	M22
Connector Name	DATA LINK CONNECTOR
Connector Type	BD16FW
Connector Color	WHITE

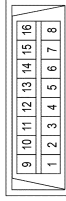

Terminal No.	Color of Wire	Signal Name
6	L	-
14	P	-

Connector No.	M23
Connector Name	COMBINATION METER
Connector Type	TH16FW-NH
Connector Color	WHITE



Terminal No.	Color of Wire	Signal Name
43	B	GND1
44	BR	POWER (IGN)
45	B	GND2
46	G	POWER (BAT)
52	P	CAN-L
53	L	CAN-H

A B C TM E F G H I J K L M N O P

CVT CONTROL SYSTEM

< WIRING DIAGRAM >

[CVT: RE0F10H]

Connector No.	M83
Connector Name	PADDLE SHIFTER (SHIFT DOWN)
Connector Type	A03FW
Connector Color	WHITE

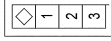

Terminal No.	Color of Wire	Signal Name
1	B	-
3	W	-

Connector No.	M174
Connector Name	JOINT CONNECTOR-M07
Connector Type	TK04FW-J
Connector Color	WHITE

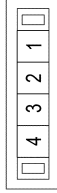

Terminal No.	Color of Wire	Signal Name
3	P	-
4	P	-

Connector No.	M175
Connector Name	JOINT CONNECTOR-M06
Connector Type	TK04FW-J
Connector Color	WHITE

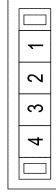

Terminal No.	Color of Wire	Signal Name
3	L	-
4	L	-

Connector No.	M81
Connector Name	CVT SHIFT SELECTOR
Connector Type	TH12FW-NH
Connector Color	WHITE

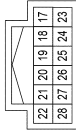

Terminal No.	Color of Wire	Signal Name
18	L	-
19	BR	-
20	G	-
21	P	-
22	V	-
23	O	-
25	Y	-
26	R	-
27	B	-

Connector No.	M82
Connector Name	PADDLE SHIFTER (SHIFT UP)
Connector Type	A04FW
Connector Color	WHITE

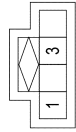

Terminal No.	Color of Wire	Signal Name
1	B	-
3	R	-

Connector No.	M24
Connector Name	COMBINATION METER
Connector Type	TH40FW-NH
Connector Color	WHITE

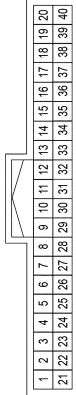

Terminal No.	Color of Wire	Signal Name
30	W	M RANGE
31	G	NOT M RANGE
32	P	AT SHIFT UP
33	BG	AT SHIFT DOWN
34	R	AT STRG SHIFT UP
35	W	AT STRG SHIFT DOWN

Connector No.	M78
Connector Name	CVT SHIFT SELECTOR
Connector Type	TH16FW-NH
Connector Color	WHITE

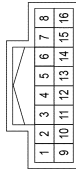

Terminal No.	Color of Wire	Signal Name
1	R	-
2	GR	-
5	L	-
7	W	-
8	BG	-
9	P	-
10	G	-
11	B	-

AADIA0936GB

CVT CONTROL SYSTEM

< WIRING DIAGRAM >

[CVT: RE0F10H]

Connector No.	E30
Connector Name	WIRE TO WIRE
Connector Type	TH80MM-CS16-TM4
Connector Color	WHITE

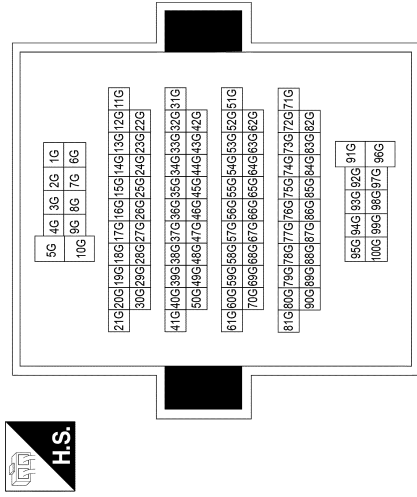

Terminal No.	Color of Wire	Signal Name
17G	L	-
18G	P	-

Connector No.	E66
Connector Name	JOINT CONNECTOR-E02
Connector Type	A06FGY
Connector Color	GRAY

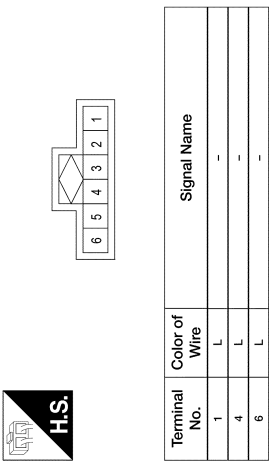

Terminal No.	Color of Wire	Signal Name
1	L	-
4	L	-
6	L	-

Connector No.	10	L
Connector Name	E10	WIRE TO WIRE
Connector Type	ECM	ECM
Connector Color	RH24FB-RZ8-L-LH	BLACK

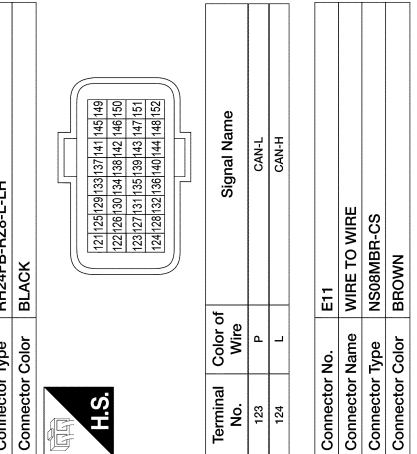

Terminal No.	Color of Wire	Signal Name
123	P	CAN-L
124	L	CAN-H

Connector No.	E11
Connector Name	WIRE TO WIRE
Connector Type	NS08MBR-CS
Connector Color	BROWN

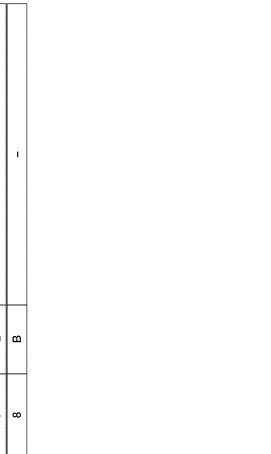

Terminal No.	Color of Wire	Signal Name
7	L	-
8	B	-

Connector No.	M176
Connector Name	JOINT CONNECTOR-M05
Connector Type	TK04FW-J
Connector Color	WHITE

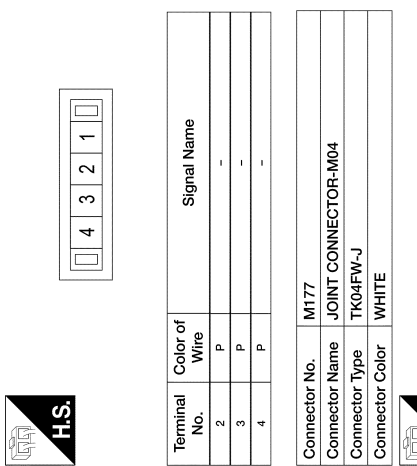

Terminal No.	Color of Wire	Signal Name
2	P	-
3	P	-
4	P	-

Connector No.	M177
Connector Name	JOINT CONNECTOR-M04
Connector Type	TK04FW-J
Connector Color	WHITE

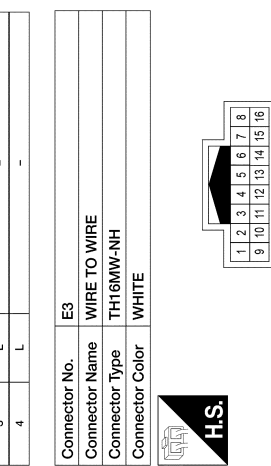

Terminal No.	Color of Wire	Signal Name
2	L	-
3	L	-
4	L	-

Connector No.	E3
Connector Name	WIRE TO WIRE
Connector Type	TH16MW-NH
Connector Color	WHITE



Terminal No.	Color of Wire	Signal Name
9	P	-

AADIA0937GB

A
B
C
TM
E
F
G
H
I
J
K
L
M
N
O
P

CVT CONTROL SYSTEM

< WIRING DIAGRAM >

[CVT: RE0F10H]

Connector No.	F50
Connector Name	IPDM E/R (INTELLIGENT POWER DISTRIBUTION MODULE ENGINE ROOM)
Connector Type	NS10FW-CS
Connector Color	WHITE

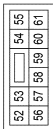

Terminal No.	Color of Wire	Signal Name
61	Y	ATECU

Connector No.	F51
Connector Name	IPDM E/R (INTELLIGENT POWER DISTRIBUTION MODULE ENGINE ROOM)
Connector Type	TH12FW-NH
Connector Color	WHITE

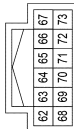

Terminal No.	Color of Wire	Signal Name
66	LG	NPSW

Connector No.	F23
Connector Name	OUTPUT SPEED SENSOR
Connector Type	RK03FB
Connector Color	BLACK



Terminal No.	Color of Wire	Signal Name
1	B	-
2	SB	-
3	Y	-

Connector No.	F43
Connector Name	CVT UNIT
Connector Type	RK22FGY
Connector Color	GRAY

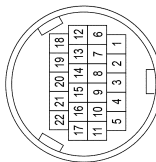

Terminal No.	Color of Wire	Signal Name
1	BR	-
2	LG	-
3	L	-
4	Y	-
5	V	-
12	V	-
13	LG	-
14	Y	-
18	L	-
22	LG	-

Connector No.	E67
Connector Name	JOINT CONNECTOR-E03
Connector Type	A06FGY
Connector Color	GRAY

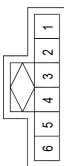

Terminal No.	Color of Wire	Signal Name
1	P	-
4	P	-
6	P	-

Connector No.	F1
Connector Name	WIRE TO WIRE
Connector Type	TH16FW-NH
Connector Color	WHITE

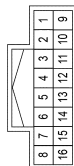

Terminal No.	Color of Wire	Signal Name
9	P	-
10	L	-

Connector No.	F2
Connector Name	WIRE TO WIRE
Connector Type	NS08FBR-CS
Connector Color	BROWN

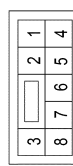

Terminal No.	Color of Wire	Signal Name
7	L	-
8	B	-

AADIA0938GB

CVT CONTROL SYSTEM

< WIRING DIAGRAM >

[CVT: RE0F10H]

4	Y	-
5	V	-
7	Y	-
8	L	-
9	BR	-
10	LG	-

Connector No.	F84
Connector Name	PRIMARY SPEED SENSOR
Connector Type	RK03FB
Connector Color	BLACK



Terminal No.	Color of Wire	Signal Name
1	B	-
2	BR	-
3	Y	-

Connector No.	F85
Connector Name	INPUT SPEED SENSOR
Connector Type	RK03FB
Connector Color	BLACK



Terminal No.	Color of Wire	Signal Name
1	B	-
2	BR	-
3	Y	-

Connector No.	F86
Connector Name	TRANSMISSION RANGE SWITCH
Connector Type	YDX06FB-HS4
Connector Color	BLACK

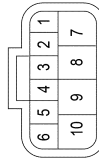

Terminal No.	Color of Wire	Signal Name
2	LG	-

Connector No.	F71
Connector Name	JOINT CONNECTOR-F03
Connector Type	RH10FB
Connector Color	BLACK

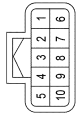

Terminal No.	Color of Wire	Signal Name
3	B	-
4	B	-
5	B	-
8	B	-
9	B	-
10	B	-

Connector No.	F83
Connector Name	JOINT CONNECTOR-F02
Connector Type	RH10FB
Connector Color	BLACK

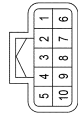

Terminal No.	Color of Wire	Signal Name
1	Y	-
2	Y	-
3	Y	-
4	Y	-
5	Y	-
6	Y	-
7	Y	-
8	Y	-
9	Y	-
10	Y	-

AADIA0939GB

A
B
C
TM
E
F
G
H
I
J
K
L
M
N
O
P

CVT CONTROL SYSTEM

< WIRING DIAGRAM >

[CVT: RE0F10H]

4	Y	-
5	BR	-
12	V	-
13	LG	-
14	Y	-
18	Y	-
22	LG	-

Connector No.	B1
Connector Name	WIRE TO WIRE
Connector Type	TH80MDGY-CS16-TM4
Connector Color	GRAY

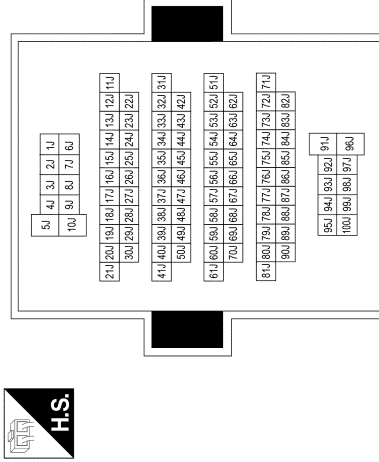

Terminal No.	Color of Wire	Signal Name
51J	P	-
52J	P	-
53J	L	-
54J	L	-

40	LG	PRI PRESS SOLE VALVE
41	B	GND
42	B	GND
43	-	-
44	-	-
45	P	BATT
46	P	BATT
47	Y	VIGN
48	Y	VIGN

Connector No.	F207
Connector Name	CONTROL VALVE
Connector Type	-
Connector Color	-

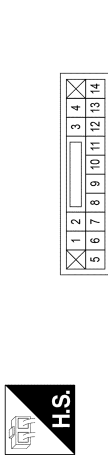

Terminal No.	Color of Wire	Signal Name
1	GR	-
2	BR	-
3	Y	-
4	P	-
5	B	-
9	O	-
10	L	-
11	W	-
12	R	-
13	BY	-

Connector No.	F209
Connector Name	CVT UNIT
Connector Type	RK22MGY-X
Connector Color	GRAY

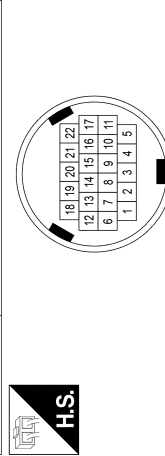

Terminal No.	Color of Wire	Signal Name
1	BR	-
2	LG	-
3	L	-

Connector No.	F89
Connector Name	TCM (TRANSMISSION CONTROL MODULE)
Connector Type	RH40FB-RZ8-L-RH
Connector Color	BLACK

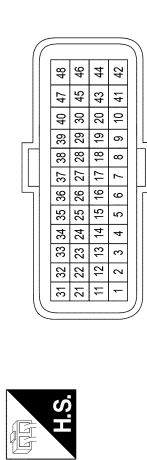

Terminal No.	Color of Wire	Signal Name
1	-	-
2	-	-
3	-	-
4	LG	D RANGE SW
5	BR	N RANGE SW
6	L	R RANGE SW
7	V	P RANGE SW
8	-	-
9	-	-
10	-	-
11	L	SENSOR GND
12	V	CVT FLUID TEMP SENS
13	-	-
14	-	-
15	-	-
16	Y	SEC PRESS SENS
17	LG	PRI PRESS SENS
18	-	-
19	-	-
20	-	-
21	-	-
22	-	-
23	P	CAN-L
24	BR	INPUT SPEED SENS
25	-	-
26	LG	SENS PWR SUPPLY
27	-	-
28	-	-
29	-	-
30	BR	LINE PRESS SOL VALVE
31	-	-
32	-	-
33	L	CAN-H
34	SB	OUTPUT SPEED SENS
35	BR	PRIMARY SPEED SENS
36	-	-
37	Y	SELECT SOL VALVE
38	V	TCC SOLE VALVE
39	L	SEC PRESS SOLE VALVE

AADIA0940GB

CVT CONTROL SYSTEM

< WIRING DIAGRAM >

[CVT: RE0F10H]

A
B
C
TM
E
F
G
H
I
J
K
L
M
N
O
P

Connector No.	B85
Connector Name	JOINT CONNECTOR-B10
Connector Type	TK04FW-J
Connector Color	WHITE

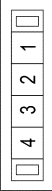

Terminal No.	Color of Wire	Signal Name
3	L	-
4	L	-

Connector No.	B82
Connector Name	JOINT CONNECTOR-B07
Connector Type	TK04FW-J
Connector Color	WHITE

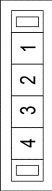

Terminal No.	Color of Wire	Signal Name
3	L	-
4	L	-

Connector No.	B83
Connector Name	JOINT CONNECTOR-B08
Connector Type	TK04FW-J
Connector Color	WHITE

Terminal No.	Color of Wire	Signal Name
3	P	-
4	P	-

Connector No.	B84
Connector Name	JOINT CONNECTOR-B09
Connector Type	TK04FW-J
Connector Color	WHITE

Terminal No.	Color of Wire	Signal Name
3	P	-
4	P	-

AADIA0941GB

CVT SHIFT LOCK SYSTEM

< WIRING DIAGRAM >

[CVT: RE0F10H]

CVT SHIFT LOCK SYSTEM

Wiring Diagram

INFOID:000000011972907

CVT SHIFT LOCK SYSTEM

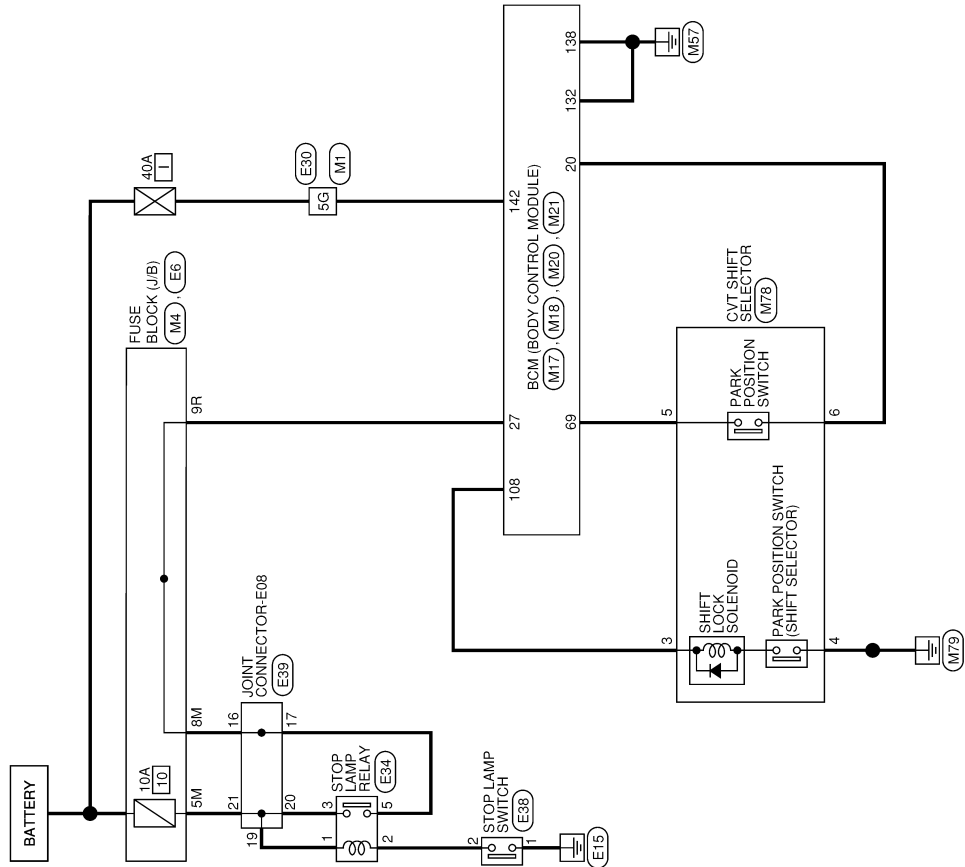

AADWA0376GB

CVT SHIFT LOCK SYSTEM

< WIRING DIAGRAM >

[CVT: RE0F10H]

CVT SHIFT LOCK SYSTEM CONNECTORS

Connector No.	M1
Connector Name	WIPE TO WIRE
Connector Type	TH80FW-CS16-TM4
Connector Color	WHITE

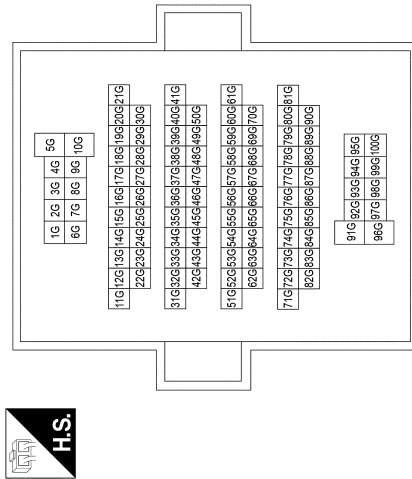

Terminal No.	5G	Color of Wire	W	Signal Name	-
--------------	----	---------------	---	-------------	---

Connector No.	M4
Connector Name	FUSE BLOCK (J/B)
Connector Type	NS16FBR-CS
Connector Color	BROWN

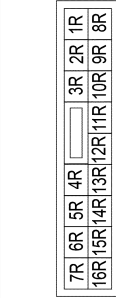

Terminal No.	9R	Color of Wire	G	Signal Name	-
--------------	----	---------------	---	-------------	---

Connector No.	M17
Connector Name	BCM (BODY CONTROL MODULE)
Connector Type	FEA09FW-FHA6-SA
Connector Color	WHITE

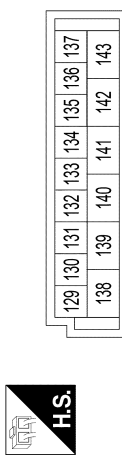

Terminal No.	132	Color of Wire	B	Signal Name	GND2
	138		B		GND1
	142		W		BAT-POWER F/L

Connector No.	M18
Connector Name	BCM (BODY CONTROL MODULE)
Connector Type	TH24FB-NH
Connector Color	BLACK

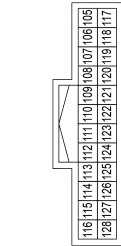

Terminal No.	108	Color of Wire	BG	Signal Name	SHIFT LOCK SOLENOID OUT
--------------	-----	---------------	----	-------------	-------------------------

Connector No.	M20
Connector Name	BCM (BODY CONTROL MODULE)
Connector Type	TH40FB-NH
Connector Color	BLACK

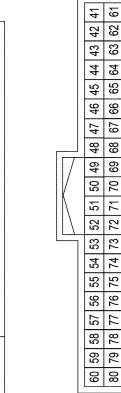

Terminal No.	69	Color of Wire	L	Signal Name	AT DEVICE OUT
--------------	----	---------------	---	-------------	---------------

Connector No.	M21
Connector Name	BCM (BODY CONTROL MODULE)
Connector Type	TH40FG-NH
Connector Color	GREEN

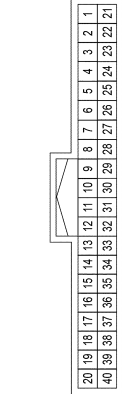

Terminal No.	20	Color of Wire	W	Signal Name	SHIFT P
	27		G		BRAKE SW LAMP

Connector No.	M78
Connector Name	CVT SHIFT SELECTOR
Connector Type	TH16FW-NH
Connector Color	WHITE

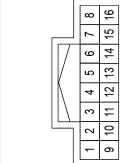

Terminal No.	3	Color of Wire	BG	Signal Name	-
	4		B		-
	5		L		-
	6		W		-

A
B
C
TM
E
F
G
H
I
J
K
L
M
N
O
P

CVT SHIFT LOCK SYSTEM

< WIRING DIAGRAM >

[CVT: RE0F10H]

17	W	-
19	P	-
20	P	-
21	P	-

Connector No.	E34
Connector Name	STOP LAMP RELAY
Connector Type	MS02FL-M2-LC
Connector Color	BLUE



Terminal No.	Color of Wire	Signal Name
1	P	-
2	R	-
3	P	-
5	W	-

Connector No.	E38
Connector Name	STOP LAMP SWITCH
Connector Type	M04FW-LC
Connector Color	WHITE



Terminal No.	Color of Wire	Signal Name
1	B	-
2	R	-

Connector No.	E39
Connector Name	JOINT CONNECTOR-E08
Connector Type	BJ30FW
Connector Color	WHITE

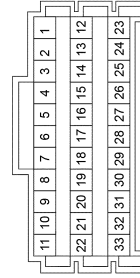

Terminal No.	Color of Wire	Signal Name
16	W	-

Connector No.	E6
Connector Name	FUSE BLOCK (J/B)
Connector Type	NS10FW-CS
Connector Color	WHITE

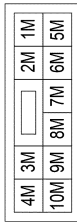

Terminal No.	Color of Wire	Signal Name
5M	P	-
8M	W	-

Connector No.	E30
Connector Name	WIRE TO WIRE
Connector Type	TH80MW-CS16-TM4
Connector Color	WHITE

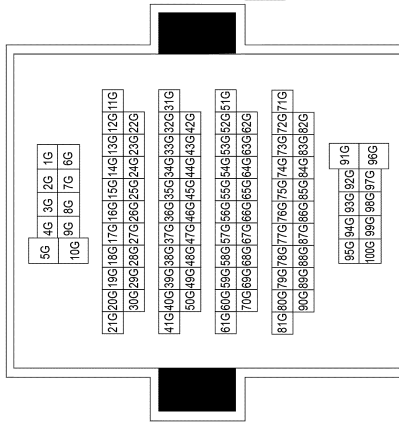

Terminal No.	Color of Wire	Signal Name
5G	P	-

AADIA0943GB

BASIC INSPECTION

DIAGNOSIS AND REPAIR WORK FLOW

Work Flow

INFOID:000000011972908

NOTE:

“DTC” includes DTC at the 1st trip.

1.OBTAIN INFORMATION ABOUT SYMPTOM

Refer to [TM-74, "Diagnostic Work Sheet"](#) and interview the customer to obtain the malfunction information (conditions and environment when the malfunction occurred) as much as possible when the customer brings in the vehicle.

>> GO TO 2.

2.CHECK DTC

1. Before checking the malfunction, check whether any DTC exists.
2. If DTC exists, perform the following operations.
 - Records the DTCs. (Print out using CONSULT and affix to the Work Order Sheet.)
 - Erase DTCs.
 - Check the relation between the cause found by DTC and the malfunction information from customer. [TM-180, "Symptom Table"](#) can be used effectively.
3. Check the relevant information including STI, etc.

Do malfunction information and DTC exists?

- Malfunction information and DTC exists.>>GO TO 3.
- Malfunction information exists but no DTC.>>GO TO 4.
- No malfunction information, but DTC exists.>>GO TO 5.

3.REPRODUCE MALFUCTION SYSTEM

Check the malfunction described by the customer on the vehicle.
 Check if the behavior is fail safe or normal operation. Refer to [TM-53, "Fail-safe"](#).
 Interview sheet can be used effectively when reproduce malfunction conditions. Refer to [TM-74, "Diagnostic Work Sheet"](#).
 Verify the relationship between the symptom and the conditions in which the malfunction described by the customer occurs.

>> GO TO 5.

4.REPRODUCE MALFUNCTION SYMPTOM

Check the malfunction described by the customer on the vehicle.
 Check if the behavior is fail safe or normal operation. Refer to [TM-53, "Fail-safe"](#).
 Interview sheet can be used effectively when reproduce malfunction conditions. Refer to [TM-74, "Diagnostic Work Sheet"](#).
 Verify the relationship between the symptom and the conditions in which the malfunction described by the customer occurs.

>> GO TO 6.

5.PERFORM “DTC CONFIRMATION PROCEDURE”

Perform “DTC CONFIRMATION PROCEDURE” of the appropriate DTC to check if DTC is detected again. Refer to [TM-57, "DTC Inspection Priority Chart"](#) when multiple DTCs are detected, and then determine the order for performing the diagnosis.

Is any DTC detected?

- YES >> GO TO 7.
- NO >> Follow [GI-41, "Intermittent Incident"](#) to check.

6.IDENTIFY MALFUNCTIONING SYSTEM WITH “DIAGNOSIS CHART BY SYMPTOM”

DIAGNOSIS AND REPAIR WORK FLOW

< BASIC INSPECTION >

[CVT: RE0F10H]

Use [TM-180, "Symptom Table"](#) from the symptom inspection result in step 4. Then identify where to start performing the diagnosis based on possible causes and symptoms.

>> GO TO 8.

7. REPAIR OR REPLACE THE MALFUNCTIONING PARTS

Repair or replace the detected malfunctioning parts.

Reconnect parts or connector after repairing or replacing, and then erase DTC if necessary.

>> GO TO 8.

8. FINAL CHECK

Perform "DTC CONFIRMATION PROCEDURE" again to make sure that the repair is correctly performed. Check that malfunctions are not reproduced when obtaining the malfunction information from the customer, referring to the symptom inspection result in step 3 or 4.

Is DTC or malfunction symptom reproduced?

YES-1 (DTC is reproduced.)>>GO TO 5.

YES-2 (Malfunction is reproduced.)>>GO TO 6.

NO >> Before delivering the vehicle to the customer, make sure that DTC is erased.

Diagnostic Work Sheet

INFOID:0000000011972909

DESCRIPTION

There are many operating conditions that may cause a malfunction of the transmission parts. By understanding those conditions properly, a quick and exact diagnosis can be achieved.

In general, perception of a problem varies depending on individuals. Ask the customer about his/her concerns carefully. It is important to understand the phenomenon or status. To systemize all the information for the diagnosis, prepare the question sheet referring to the question points.

In some cases, multiple conditions that appear simultaneously may cause a DTC to be detected.

KEY POINTS

WHAT Vehicle & engine model
WHEN Date, Frequencies
WHERE..... Road conditions
HOW Operating conditions,
 Weather conditions,
 Symptoms

SEF907L

Worksheet Sample

Question sheet						
Customer's name	MR/MS	Registration number		Initial year registration	Year	Month day
		Vehicle type		Chassis No.		
Storage date	Year	Month day	Engine	Mileage		km/mile
Symptom		<input type="checkbox"/> Vehicle does not start. (<input type="checkbox"/> R position <input type="checkbox"/> D position <input type="checkbox"/> DS position <input type="checkbox"/> M position) <input type="checkbox"/> Upshifting does not occur. <input type="checkbox"/> Downshifting does not occur. <input type="checkbox"/> Lock-up malfunction <input type="checkbox"/> Shift point is too high. <input type="checkbox"/> Shift point is too low. <input type="checkbox"/> Shift shock (<input type="checkbox"/> N⇒D <input type="checkbox"/> Lock-up <input type="checkbox"/> R, D, DS and M position) <input type="checkbox"/> Slip (<input type="checkbox"/> N⇒D <input type="checkbox"/> Lock-up <input type="checkbox"/> R, D, DS and M position) <input type="checkbox"/> Noise <input type="checkbox"/> Vibration When selector lever position is shifted, shift pattern does not change. <input type="checkbox"/> Other ()				
First occurrence		<input type="checkbox"/> Recently (as from month of year)				
Frequency of occurrence		<input type="checkbox"/> Always <input type="checkbox"/> Under certain conditions <input type="checkbox"/> Sometimes (time(s)/day)				

DIAGNOSIS AND REPAIR WORK FLOW

< BASIC INSPECTION >

[CVT: RE0F10H]

Question sheet

Customer's name	MR/MS	Registration number		Initial year registration	Year Month day
		Vehicle type		Chassis No.	
Storage date	Year Month day	Engine		Mileage	km/mile
Climate conditions		Irrelevant			
	Weather	<input type="checkbox"/> Clear <input type="checkbox"/> Cloud <input type="checkbox"/> Rain <input type="checkbox"/> Snow <input type="checkbox"/> Others)			
	Temperature	<input type="checkbox"/> Hot <input type="checkbox"/> Warm <input type="checkbox"/> Cool <input type="checkbox"/> Cold <input type="checkbox"/> Temperature (Approx. °C/°F)			
	Relative humidity	<input type="checkbox"/> High <input type="checkbox"/> Moderate <input type="checkbox"/> Low			
Transaxle condition		<input type="checkbox"/> In cold-start <input type="checkbox"/> During warm-up (approx. °C/°F) <input type="checkbox"/> After warm-up <input type="checkbox"/> Engine speed: rpm			
Road conditions		<input type="checkbox"/> Urban area <input type="checkbox"/> Suburb area <input type="checkbox"/> Highway <input type="checkbox"/> Mountainous road (uphill or downhill)			
Operating condition, etc.		Irrelevant <input type="checkbox"/> When engine starts <input type="checkbox"/> During idling <input type="checkbox"/> During driving <input type="checkbox"/> During acceleration <input type="checkbox"/> At constant speed driving <input type="checkbox"/> During deceleration <input type="checkbox"/> During cornering (RH curve or LH curve)			
Other conditions					

A
B
C
TM
E
F
G
H
I
J
K
L
M
N
O
P

ADDITIONAL SERVICE WHEN REPLACING TCM

< BASIC INSPECTION >

[CVT: RE0F10H]

ADDITIONAL SERVICE WHEN REPLACING TCM

Description

INFOID:000000011972910

Always perform the following items when the TCM is replaced. For work procedure, refer to [TM-76, "Work Procedure"](#).

SAVING AND WRITING OF TCM DATA

- TCM performs accurate control by retrieving data (inherent characteristic value) of each solenoid. For this reason, it is necessary to save data of current TCM in CONSULT before replacing the TCM. After this, the saved data must be written in new TCM.

Work Procedure

INFOID:000000011972911

CAUTION:

When replacing TCM together with transaxle assembly, perform "ADDITIONAL SERVICE WHEN REPLACING TRANSAXLE ASSEMBLY". Refer to [TM-77, "Work Procedure"](#).

1.SAVE THE TCM DATA

NOTE:

Save necessary data stored in TCM in CONSULT according to the following instructions:

1. Turn ignition switch OFF and wait for 10 seconds.
2. Turn ignition switch ON.
3. Select "Work Support" in "TRANSMISSION".
4. Select "READ IP CHARA - REPLACEMENT TCM".
5. Import data according to the instructions on the CONSULT screen.

>> GO TO 2.

2.REPLACE THE TCM

1. Turn ignition switch OFF and wait for 10 seconds.
2. Replace the TCM. Refer to [TM-191, "Removal and Installation"](#).

>> GO TO 3.

3.WRITE THE TCM DATA

NOTE:

Write data saved in CONSULT into a new TCM according to the following instructions:

1. Turn ignition switch OFF and wait for 10 seconds.
2. Turn ignition switch ON.
3. Select "Work Support" in "TRANSMISSION".
4. Select "WRITE IP CHARA - REPLACEMENT TCM".
5. Write data saved in CONSULT in TCM according to the instructions on the CONSULT screen.

>> WORK END

ADDITIONAL SERVICE WHEN REPLACING TRANSAXLE ASSEMBLY

< BASIC INSPECTION >

[CVT: RE0F10H]

ADDITIONAL SERVICE WHEN REPLACING TRANSAXLE ASSEMBLY

Description

INFOID:0000000011972912

Perform the following work after the transaxle assembly is replaced. For work procedure, refer to [TM-77](#), "[Work Procedure](#)".

ERASING AND WRITING TCM DATA

- TCM performs accurate control by retrieving data (inherent characteristic value) of each solenoid. For this reason, after replacing transaxle assembly, it is necessary to erase data stored in TCM and write new data.

ERASING OF CVT FLUID DEGRADATION LEVEL DATA

- TCM records the degradation level of the CVT fluid calculated from the vehicle driving status. Therefore, if the transaxle assembly is replaced, it is necessary to erase the CVT fluid degradation level data recorded by TCM.

Work Procedure

INFOID:0000000011972913

1. CHECK THE SERIAL NUMBER (PART 1)

Write down the serial number of new transaxle assembly.

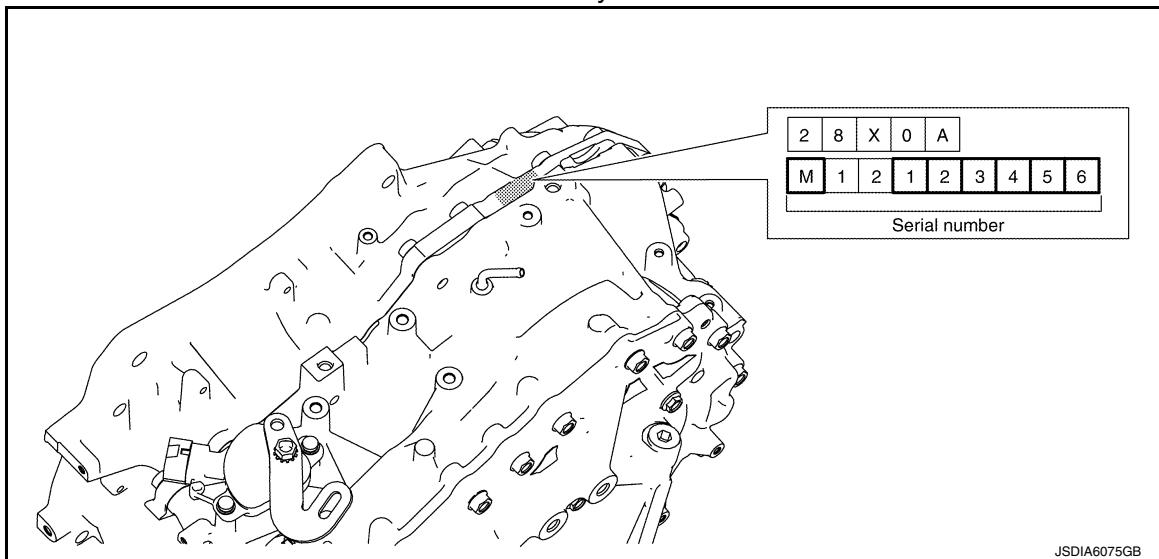

>> GO TO 2.

2. CHECK THE SERIAL NUMBER (PART 2)

1. Turn ignition switch ON.
2. Insert the attached CD into CONSULT.
3. Select "Work Support" in "TRANSMISSION".
4. Select "WRITE IP CHARA - REPLACEMENT AT/CVT".
5. Check that the serial number displayed on CONSULT screen and those written in the memo agree.

CAUTION:

Never perform writing procedure.

6. Go back to MENU of "Work Support".

>> GO TO 3.

3. INITIALIZE TCM

1. Set parking brake.
2. Select "ERASE MEMORY DATA".
3. Touch "Start" according to the instructions on the CONSULT screen.

Is "COMPLETED" displayed?

YES >> GO TO 4.

NO >> Turn ignition switch OFF and wait for a minimum of 10 seconds then perform the work again.

ADDITIONAL SERVICE WHEN REPLACING TRANSAXLE ASSEMBLY

< BASIC INSPECTION >

[CVT: RE0F10H]

4. WRITE THE DATA

NOTE:

Write data of new solenoid in TCM according to the following instructions:

1. Shift the selector lever to the P position.
2. Turn ignition switch OFF and wait for 10 seconds.
3. Turn ignition switch ON.
4. Select "Work Support" in "TRANSMISSION".
5. Select "WRITE IP CHARA - REPLACEMENT AT/CVT".
6. Write data in TCM according to the instructions on the CONSULT screen.

NOTE:

When writing is complete, the shift position indicator of the combination meter displays P.

>> GO TO 5.

5. ERASE CVT FLUID DEGRADATION LEVEL DATA

1. Select "WORK SUPPORT" in "TRANSMISSION".
2. Select "CONFORM CVTF DETERIORATION".
3. Touch "Clear".

>> WORK END

ADDITIONAL SERVICE WHEN REPLACING TCM AND TRANSAXLE ASSEMBLY

< BASIC INSPECTION >

[CVT: RE0F10H]

ADDITIONAL SERVICE WHEN REPLACING TCM AND TRANSAXLE ASSEMBLY

Description

INFOID:0000000011972914

When replacing TCM and transaxle assembly simultaneously, perform the following work. For work procedure, refer to [TM-79. "Work Procedure"](#).

TCM PROGRAMMING

- Since vehicle specifications are not yet written in a new TCM, it is necessary to write them with CONSULT.

CAUTION:

When replacing TCM, save TCM data on CONSULT before removing TCM.

WRITING TCM DATA

- TCM performs accurate control by retrieving data (inherent characteristic value) of each solenoid. For this reason, after replacing TCM and transaxle assembly, it is necessary to write new data in TCM.

Work Procedure

INFOID:0000000011972915

1. SAVE TCM DATA (VEHICLE SPECIFICATIONS)

Ⓜ With CONSULT

1. Turn ignition switch OFF.
2. Turn ignition switch ON.
3. Select "Re/programming, Configuration".
4. Select "AT/CVT".

NOTE:

If "AT/CVT" is not displayed and TCM data cannot be saved on CONSULT, GO TO 2.

5. Select "Programming".
6. Save TCM data on CONSULT according to the CONSULT display.

>> GO TO 2.

2. REPLACE TCM AND TRANSAXLE ASSEMBLY

1. Turn ignition switch OFF and wait for 10 seconds.
2. Replace TCM and transaxle assembly. Refer to [TM-191. "Removal and Installation"](#) (TCM), [TM-212. "Removal and Installation"](#) (Transaxle assembly).

CAUTION:

Write down the serial number of new transaxle assembly.

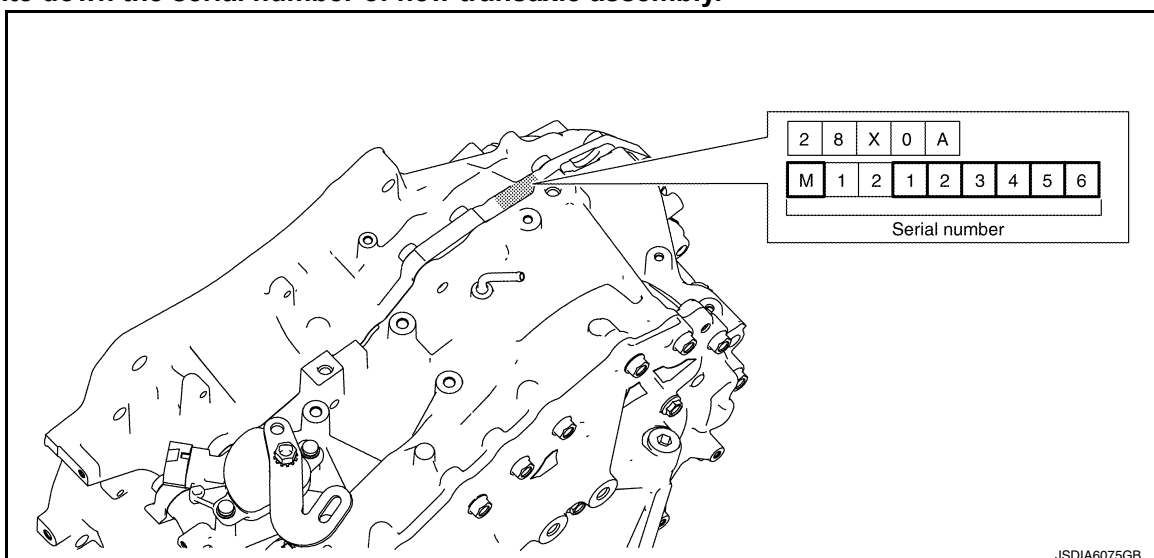

>> GO TO 3.

ADDITIONAL SERVICE WHEN REPLACING TCM AND TRANSAXLE ASSEMBLY

< BASIC INSPECTION >

[CVT: RE0F10H]

3. WRITE TCM DATA (VEHICLE SPECIFICATIONS)

With CONSULT

1. Select "Programming".
2. Perform programming according to the CONSULT display.

>> GO TO 4.

4. WRITE TCM DATA (IP CHARACTERISTICS VALUE)

NOTE:

Write data of new solenoid in TCM according to the following instructions:

With CONSULT

CAUTION:

When the work is interrupted, obtain data again from the supplied CD.

1. Shift the selector lever to the P position.
2. Turn ignition switch OFF and wait for 10 seconds.
3. Turn ignition switch ON.
4. Insert the supplied CD into CONSULT.
5. Select "Work Support" in "TRANSMISSION".
6. Select "WRITE IP CHARA - REPLACEMENT AT/CVT".
7. Check that the serial number displayed on CONSULT screen and those written in the memo agree.
8. Write data in TCM according to the instructions on the CONSULT screen.

NOTE:

When writing is complete, the shift position indicator of the combination meter displays P.

>> WORK END

CVT FLUID

Replacement

INFOID:0000000011972916

- CVT fluid : Refer to [TM-218, "General Specification"](#).
 Fluid capacity : Refer to [TM-218, "General Specification"](#).

CAUTION:

- Always use shop paper. Never use shop cloth.
- Replace a drain plug gasket with new ones at the final stage of the operation when installing.
- Use caution when looking into the drain hole as there is a risk of dripping fluid entering the eye.
- After replacement, always perform CVT fluid leakage check.

1. Select "Data Monitor" in "TRANSMISSION" using CONSULT.
2. Select "FLUID TEMP" and confirm that the CVT fluid temperature is 40°C (104°F) or less.
3. Check that the selector lever is in the "P" position, then completely engage the parking brake.
4. Lift up the vehicle.
5. Remove the drain plug and drain the CVT fluid from the oil pan. Refer to [TM-195, "Exploded View"](#).
6. Install the drain plug to oil pan.

CAUTION:

Drain plug gasket use the old one.

7. Remove the overflow plug ① from converter housing.

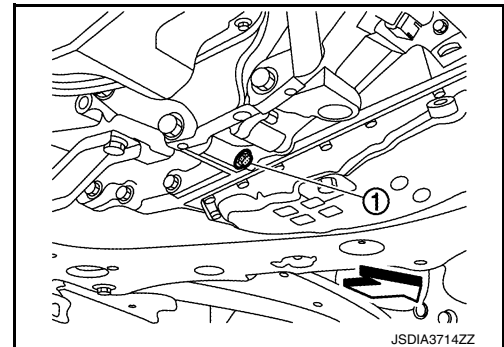

8. Install the charging pipe set (KV311039S0) (A) into the overflow plug hole.

CAUTION:

Tighten the charging pipe by hand.

9. Install the ATF changer hose (B) to the charging pipe.

CAUTION:

Press the ATF changer hose all the way onto the charging pipe until it stops.

10. Fill approximately 3 liter (2-5/8 Imp qt) of the CVT fluid.
11. Remove the ATF changer hose and charging pipe, then install the overflow plug.

NOTE:

Perform this work quickly because CVT fluid leaks.

12. Lift down the vehicle.
13. Start the engine.
14. While depressing the brake pedal, shift the selector lever to the entire position from "P" to "DS", and shift it to the "P" position.

NOTE:

Hold the lever at each position for 5 seconds.

15. Check that the CONSULT "Data Monitor" in "FLUID TEMP" is 35°C (95°F) to 45°C (113°F).
16. Stop the engine.
17. Lift up the vehicle.
18. Remove the drain plug, and then drain CVT fluid from oil pan.

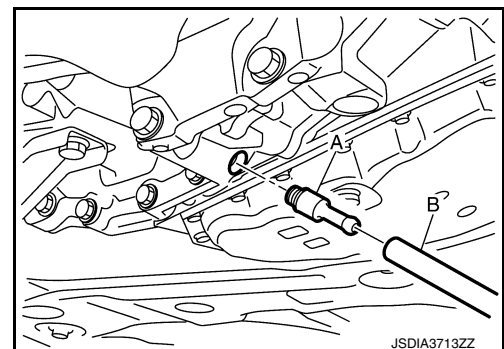

< BASIC INSPECTION >

19. Repeat steps 8 to 18 (one time).
20. Tighten the drain plug to the specified torque. Refer to [TM-195, "Exploded View"](#).
21. Remove the overflow plug.
22. Install the charging pipe set (KV311039S0) into the overflow plug hole.
CAUTION:
Tighten the charging pipe by hand.
23. Install the ATF changer hose to the charging pipe.
CAUTION:
Press the ATF changer hose all the way onto the charging pipe until it stops.
24. Fill approximately 3 liter (2-5/8 Imp qt) of the CVT fluid.
25. Remove the ATF changer hose and charging pipe, then install the overflow plug.
NOTE:
Perform this work quickly because CVT fluid leaks.
26. Lift down the vehicle.
27. Start the engine.
28. While depressing the brake pedal, shift the selector lever to the entire position from "P" to "DS", and shift it to the "P" position.
NOTE:
Hold the lever at each position for 5 seconds.
29. Check that the CONSULT "Data Monitor" in "FLUID TEMP" is 35°C (95°F) to 45°C (113°F).
30. Lift up the vehicle.
31. Remove the overflow plug and confirm that the CVT fluid is drained from the overflow plug hole.
CAUTION:
Perform this work with the vehicle idling.
NOTE:
If the CVT fluid is not drained, refer to "Adjustment" and refill with the CVT fluid.
32. When the flow of CVT fluid slows to a drip, tighten the overflow plug to the specified torque. Refer to [TM-195, "Exploded View"](#).
CAUTION:
Never reuse O-ring.
33. Lift down the vehicle.
34. Select "Data Monitor" in "TRANSMISSION" using CONSULT.
35. Select "CONFORM CVTF DETERIORTN".
36. Select "Erase".
37. Stop the engine.

Adjustment

INFOID:000000011972917

- CVT fluid** : Refer to [TM-218, "General Specification"](#).
Fluid capacity : Refer to [TM-218, "General Specification"](#).

CAUTION:

- During adjustment of the CVT fluid level, check CONSULT so that the oil temperature may be maintained from 35 to 45°C (95 to 113°F).
- During adjustment of the CVT fluid level, check that the engine speed is maintaining 500 rpm.
- Use caution when looking into the drain hole as there is a risk of dripping fluid entering the eye.

1. Check that the selector lever is in the "P" position, then completely engage the parking brake.
2. Start the engine.
3. Adjust the CVT fluid temperature to be approximately 40°C (104°F).

NOTE:

The CVT fluid is largely affected by temperature. Therefore be sure to use CONSULT and check the "FLUID TEMP" under "TRANSMISSION" in "Data Monitor" while adjusting.

4. While depressing the brake pedal, shift the selector lever to the entire position from "P" to "DS", and shift it to the "P" position.

NOTE:

CVT FLUID

< BASIC INSPECTION >

[CVT: RE0F10H]

Hold the lever at each position for 5 seconds.

5. Lift up the vehicle.
6. Check that there is no CVT fluid leakage.
7. Remove the overflow plug ① from converter housing.

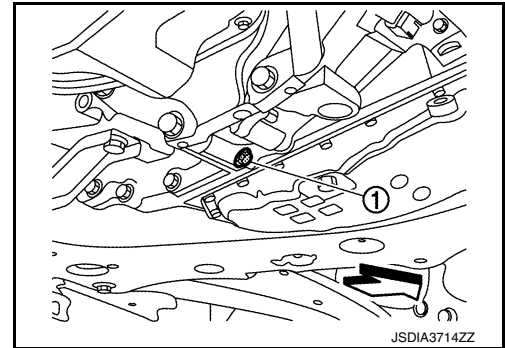

8. Install the charging pipe set (KV311039S0) (A) into the overflow plug hole.

CAUTION:

Tighten the charging pipe by hand.

9. Install the ATF changer hose (B) to the charging pipe.

CAUTION:

Press the ATF changer hose all the way onto the charging pipe until it stops.

10. Fill approximately 0.5 liter (1/2 Imp qt) of the CVT fluid.
11. Remove the ATF changer hose from the charging pipe, and check that the CVT fluid drains out from the charging pipe. If it does not drain out, perform charging again.

CAUTION:

Perform this work with the vehicle idling.

12. When the flow of CVT fluid slows to a drip, remove the charging pipe from the converter housing.
13. Tighten the overflow plug to the specified torque. Refer to [TM-195. "Exploded View"](#).

CAUTION:

Never reuse O-ring.

14. Lift down the vehicle.
15. Stop the engine.

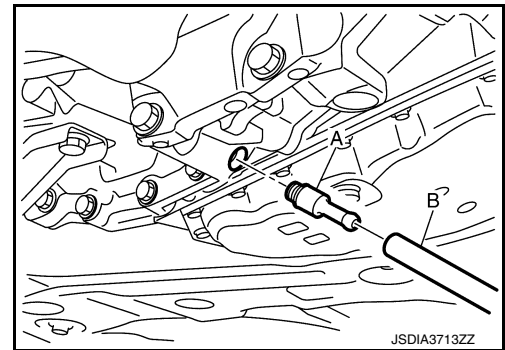

STALL TEST

< BASIC INSPECTION >

[CVT: RE0F10H]

STALL TEST

Work Procedure

INFOID:000000011972918

INSPECTION

1. Check the engine oil level. Replenish if necessary. Refer to [LU-8, "Inspection"](#).
2. Check for leak of the CVT fluid. Refer to [TM-184, "Inspection"](#).
3. Drive for about 10 minutes to warm up the vehicle so that the CVT fluid temperature is 50 to 80°C (122 to 176°F).
4. Be sure to apply the parking brake and block the tires.
5. Start the engine, depress the brake pedal and shift the selector lever to "D" position.
6. While depressing the brake pedal, depress the accelerator pedal gradually.
7. Read the stall speed quickly and release your foot from the accelerator pedal quickly.

CAUTION:

Do not depress the accelerator pedal for 5 seconds or more during the test.

Stall speed : Refer to [TM-218, "Stall Speed"](#).

8. Shift the selector lever to "N" position.
9. Cool the CVT fluid.
CAUTION:
Run the engine with the idle speed for at least 1 minute.
10. Put the selector lever to the R position and perform Step 6 to Step 9 again.

NARROWING-DOWN MALFUNCTIONING PARTS

	Selector lever position		Possible cause
	D	R	
Stall speed	H	O	• Forward clutch
	O	H	• Reverse brake
	L	L	• Engine • Torque converter one way clutch
	H	H	• Line pressure is low. • Primary pulley • Secondary pulley • Chain belt

O: Within the stall speed standard value.

H: Stall speed is higher than the standard value.

L: Stall speed is lower than the standard value.

CVT POSITION

Inspection

INFOID:0000000011972919

1. Turn ON the ignition switch with the shift selector at the "P" position.
2. Press the shift selector button with the brake pedal depressed, and confirm that the shift selector can be moved to positions other than "P". Also confirm that movement is not allowed from the "P" position to other position without depressing the brake pedal.
3. Move the shift selector and check for "excessive effort", "sticking", "noise" or "rattle".
4. Confirm that shift selector stops at each position with the feel of engagement when it is moved through all the positions. Check whether or not the actual position the shift selector is in matches the position shown by the transaxle body.
5. Make sure that the shift selector is moved to all the shift positions in the manner shown.
 - (A): Shift selector can be operated without pressing the shift selector button.
 - (B): Press shift selector button to operate shift selector, while depressing the brake pedal.
6. When the shift selector button is pressed without applying forward/backward force to the shift selector at "P", "R", "N", "D" or "M" positions, there should be no "sticking" on the shift selector button operation.
7. Check that the back-up lamps do not illuminate when the shift selector is in the "P" position.
8. Check that the engine can be started with the shift selector in the "P" and "N" positions only.
9. Check that the transaxle is locked completely when the shift selector is in the "P" position.

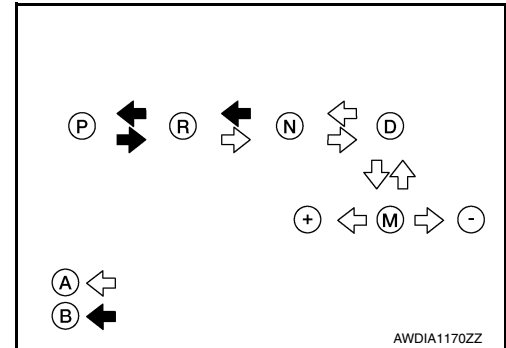

Adjustment

INFOID:0000000011972920

1. Shift the shift selector to the "P" position.
CAUTION:
Turn wheels at least a quarter turn and be certain the park position mechanism is fully engaged.
2. Loosen the control cable nut (A) and set manual lever (B) the the "P" position.
⇐: Front
CAUTION:
Do not apply force to the manual lever.
3. Position the manual lever in the "P" position.
4. Tighten the control cable nut to specified torque. Refer to [TM-187, "Exploded View"](#).
CAUTION:
Hold manual lever securely in the "P" position when tightening control cable nut (A).

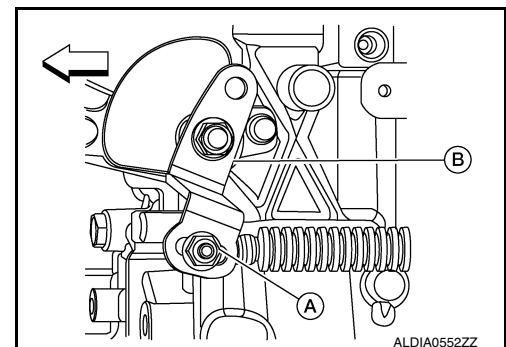

HOW TO ERASE PERMANENT DTC

< BASIC INSPECTION >

[CVT: RE0F10H]

HOW TO ERASE PERMANENT DTC

Description

INFOID:000000011972921

Permanent DTC can be erased by driving each driving pattern. ECM recognizes each driving pattern; it transmits signals to each control module when the driving is complete. Each control module erases permanent DTC based on those signals. For details, refer to [TM-86, "Description"](#).

U0073 COMMUNICATION BUS A OFF

< DTC/CIRCUIT DIAGNOSIS >

[CVT: RE0F10H]

DTC/CIRCUIT DIAGNOSIS

U0073 COMMUNICATION BUS A OFF

DTC Description

INFOID:000000012436439

DTC DETECTION LOGIC

TCM communication blockage lasts for 2 seconds or more when turning ON the ignition switch. (Communication not established.)

DTC	CONSULT screen terms (Trouble diagnosis content)	DTC detection condition	
		Diagnosis condition	When turning ON the ignition switch
U0073	COMM BUS A OFF (Control Module Communication Bus A Off)	Signal	CAN communication
		Threshold	TCM communication blockage (Communication not established)
		Diagnosis delay time	Last for 2 seconds or more

POSSIBLE CAUSE

Harness or connector (CAN communication line is error)

FAIL-SAFE

- Selector shock is large
- Start is slow
- Acceleration is slow
- Lock-up is not performed

DTC CONFIRMATION PROCEDURE

1. PREPARATION BEFORE WORK

If another "DTC CONFIRMATION PROCEDURE" occurs just before, turn ignition switch OFF and wait for at least 10 seconds, then perform the next test.

>> GO TO 2.

2. PERFORM DTC CONFIRMATION PROCEDURE

1. Start the engine and wait for at least 5 seconds.
2. Check the DTC.

Is "U0073" detected?

- YES >> Go to [TM-87, "Diagnosis Procedure"](#).
- NO-1 >> To check malfunction symptom before repair: Refer to [GI-41, "Intermittent Incident"](#).
- NO-2 >> Confirmation after repair: INSPECTION END

Diagnosis Procedure

INFOID:000000012436440

For the diagnosis procedure, refer to [LAN-17, "Trouble Diagnosis Flow Chart"](#).

U0100 LOST COMMUNICATION (ECM A)

< DTC/CIRCUIT DIAGNOSIS >

[CVT: RE0F10H]

U0100 LOST COMMUNICATION (ECM A)

DTC Description

INFOID:000000012436441

DTC DETECTION LOGIC

When the ignition switch is ON, TCM is unable to receive the CAN communications signal from ECM continuously for 2 seconds or more.

DTC	CONSULT screen terms (Trouble diagnosis content)	DTC detection condition	
		Diagnosis condition	When the ignition switch is ON
U0100	LOST COMM (ECM A) (Lost Communication With ECM/PCM A)	Signal	CAN communication signal
		Threshold	TCM is unable to receive the CAN communications signal from ECM
		Diagnosis delay time	Continuously for 2 seconds or more

POSSIBLE CAUSE

- ECM
- Harness or connector (CAN communication line is open or shorted)

FAIL-SAFE

- Selector shock is large
- Start is slow
- Acceleration is slow
- Lock-up is not performed

DTC CONFIRMATION PROCEDURE

1. PREPARATION BEFORE WORK

If another "DTC CONFIRMATION PROCEDURE" occurs just before, turn ignition switch OFF and wait for at least 10 seconds, then perform the next test.

>> GO TO 2.

2. PERFORM DTC CONFIRMATION PROCEDURE

1. Start the engine and wait for at least 5 seconds.
2. Check the DTC.

Is "U0100" detected?

YES >> Go to [TM-88, "Diagnosis Procedure"](#).

NO-1 >> To check malfunction symptom before repair: Refer to [GI-41, "Intermittent Incident"](#).

NO-2 >> Confirmation after repair: INSPECTION END

Diagnosis Procedure

INFOID:000000012436442

For the diagnosis procedure, refer to [LAN-17, "Trouble Diagnosis Flow Chart"](#).

U0140 LOST COMMUNICATION (BCM)

< DTC/CIRCUIT DIAGNOSIS >

[CVT: RE0F10H]

U0140 LOST COMMUNICATION (BCM)

DTC Description

INFOID:000000012436443

DTC DETECTION LOGIC

When the ignition switch is ON, TCM is unable to receive the CAN communications signal from BCM continuously for 2 seconds or more.

DTC	CONSULT screen terms (Trouble diagnosis content)	DTC detection condition	
		Diagnosis condition	When the ignition switch is ON
U0140	LOST COMM (BCM) (Lost Communication With Body Control Module)	Signal	CAN communication signal
		Threshold	TCM is unable to receive the CAN communications signal from BCM
		Diagnosis delay time	Continuously for 2 seconds or more

POSSIBLE CAUSE

- BCM
- Harness or connector (CAN communication line is open or shorted)

FAIL-SAFE

Not changed from normal driving

DTC CONFIRMATION PROCEDURE

1. PREPARATION BEFORE WORK

If another "DTC CONFIRMATION PROCEDURE" occurs just before, turn ignition switch OFF and wait for at least 10 seconds, then perform the next test.

>> GO TO 2.

2. PERFORM DTC CONFIRMATION PROCEDURE

With CONSULT

1. Start the engine and wait for at least 5 seconds.
2. Check the DTC.

Is "U0140" detected?

- YES >> Go to [TM-89, "Diagnosis Procedure"](#).
- NO-1 >> To check malfunction symptom before repair: Refer to [GI-41, "Intermittent Incident"](#).
- NO-2 >> Confirmation after repair: INSPECTION END

Diagnosis Procedure

INFOID:000000012436444

For the diagnosis procedure, refer to [LAN-17, "Trouble Diagnosis Flow Chart"](#).

U0141 LOST COMMUNICATION (BCM A)

< DTC/CIRCUIT DIAGNOSIS >

[CVT: RE0F10H]

U0141 LOST COMMUNICATION (BCM A)

DTC Description

INFOID:000000012436445

DTC DETECTION LOGIC

When the ignition switch is turned ON, TCM continues no reception of the CAN communication signal from IPDM E/R for 2 seconds or more.

DTC	CONSULT screen terms (Trouble diagnosis content)	DTC detection condition	
U0141	LOST COMM (BCM A) (Lost Communication With Body Control Module A)	Diagnosis condition	When the ignition switch is turned ON
		Signal	CAN communication signal
		Threshold	TCM continues no reception of the CAN communication signal from IPDM E/R
		Diagnosis delay time	2 seconds or more

POSSIBLE CAUSE

- IPDM E/R
- Harness or connector (CAN communication line is open or shorted)

FAIL-SAFE

Not changed from normal driving

DTC CONFIRMATION PROCEDURE

1. PREPARATION BEFORE WORK

If another "DTC CONFIRMATION PROCEDURE" occurs just before, turn ignition switch OFF and wait for at least 10 seconds, then perform the next test.

>> GO TO 2.

2. PERFORM DTC CONFIRMATION PROCEDURE

With CONSULT

1. Start the engine and wait for at least 5 seconds.
2. Check the DTC.

Is "U0141" detected?

- YES >> Go to [TM-90, "Diagnosis Procedure"](#).
- NO-1 >> To check malfunction symptom before repair: Refer to [GI-41, "Intermittent Incident"](#).
- NO-2 >> Confirmation after repair: INSPECTION END

Diagnosis Procedure

INFOID:000000012436446

For the diagnosis procedure, refer to [LAN-17, "Trouble Diagnosis Flow Chart"](#).

U0155 LOST COMMUNICATION (IPC)

< DTC/CIRCUIT DIAGNOSIS >

[CVT: RE0F10H]

U0155 LOST COMMUNICATION (IPC)

DTC Description

INFOID:000000012436447

DTC DETECTION LOGIC

When the ignition switch is ON, TCM is unable to receive the CAN communications signal from the combination meter continuously for 2 seconds or more.

DTC	CONSULT screen terms (Trouble diagnosis content)	DTC detection condition	
		Diagnosis condition	When the ignition switch is ON
U0155	LOST COMM (IPC) [Lost Communication With Instrument Panel Cluster (IPC) Control Module]	Signal	CAN communication signal
		Threshold	TCM is unable to receive the CAN communications signal from the combination meter
		Diagnosis delay time	Continuously for 2 seconds or more

POSSIBLE CAUSE

- Combination meter
- Harness or connector (CAN communication line is open or shorted)

FAIL-SAFE

Not changed from normal driving

DTC CONFIRMATION PROCEDURE

1. PREPARATION BEFORE WORK

If another "DTC CONFIRMATION PROCEDURE" occurs just before, turn ignition switch OFF and wait for at least 10 seconds, then perform the next test.

>> GO TO 2.

2. PERFORM DTC CONFIRMATION PROCEDURE

With CONSULT

1. Start the engine and wait for at least 5 seconds.
2. Check the DTC.

Is "U0155" detected?

- YES >> Go to [TM-91, "Diagnosis Procedure"](#).
- NO-1 >> To check malfunction symptom before repair: Refer to [GI-41, "Intermittent Incident"](#).
- NO-2 >> Confirmation after repair: INSPECTION END

Diagnosis Procedure

INFOID:000000012436448

For the diagnosis procedure, refer to [LAN-17, "Trouble Diagnosis Flow Chart"](#).

U0300 CAN COMMUNICATION DATA

< DTC/CIRCUIT DIAGNOSIS >

[CVT: RE0F10H]

U0300 CAN COMMUNICATION DATA

DTC Description

INFOID:000000012436449

DTC DETECTION LOGIC

When the ignition switch is ON, the data length transmitted from each control unit is shorter than the specified length and the status continues for 2 seconds or more.

DTC	CONSULT screen terms (Trouble diagnosis content)	DTC detection condition	
U0300	CAN COMM DATA (Internal Control Module Software In-compatibility)	Diagnosis condition	When the ignition switch is ON
		Signal	CAN communication data
		Threshold	The data length transmitted from each control unit is shorter than the specified length and the status
		Diagnosis delay time	Continues for 2 seconds or more

POSSIBLE CAUSE

Control unit other than TCM

FAIL-SAFE

- Selector shock is large
- Start is slow
- Acceleration is slow
- Lock-up is not performed

DTC CONFIRMATION PROCEDURE

1. PREPARATION BEFORE WORK

If another "DTC CONFIRMATION PROCEDURE" occurs just before, turn ignition switch OFF and wait for at least 10 seconds, then perform the next test.

>> GO TO 2.

2. CHECK DTC DETECTION

With CONSULT

1. Start the engine and wait for 5 seconds or more.
2. Check the DTC.

Is "U0300" detected?

- YES >> Go to [TM-92, "Diagnosis Procedure"](#).
NO-1 >> To check malfunction symptom before repair: Refer to [GI-41, "Intermittent Incident"](#).
NO-2 >> Confirmation after repair: INSPECTION END

Diagnosis Procedure

INFOID:000000012436450

1. CONTROL UNIT CHECK

Check the number of control units replaced before "U0300" is detected.

Is one control unit replaced?

- YES >> The specification of the control unit replaced may be incorrect. Check the part number and the specification.
NO >> GO TO 2.

2. CONTROL UNIT CHECK

With CONSULT

1. Remove one of the control unit replaced.
2. Assemble the old control unit before replacement.
3. Turn ignition switch ON, and wait for 2 seconds or more.
4. Select "Self Diagnostic Results" in "TRANSMISSION".

U0300 CAN COMMUNICATION DATA

< DTC/CIRCUIT DIAGNOSIS >

[CVT: RE0F10H]

Is "U0300" detected?

- YES >> Turn OFF the ignition switch and check other control units in the same manner.
- NO >> The specification of the control unit removed may be incorrect. Check the part number and the specification.

A
B
C
TM
E
F
G
H
I
J
K
L
M
N
O
P

U1000 CAN COMM CIRCUIT

DTC Description

INFOID:000000012436451

CAN (Controller Area Network) is a serial communication line for real-time application. It is an on-vehicle multiplex communication line with high data communication speed and excellent malfunction detection ability. Many electronic control units are equipped onto a vehicle, and each control unit shares information and links with other control units during operation (not independently). In CAN communication, control units are connected with 2 communication lines (CAN-H line, CAN-L line) allowing a high rate of information transmission with less wiring. Each control unit transmits/receives data but selectively reads required data only.

DTC DETECTION LOGIC

When the ignition switch is ON, TCM cannot send the CAN communication signal continuously for 2 seconds or more.

DTC	CONSULT screen terms (Trouble diagnosis content)	DTC detection condition	
U1000	CAN COMM CIRCUIT (CAN Communication Line)	Diagnosis condition	When the ignition switch is ON
		Signal	CAN communication signal
		Threshold	TCM cannot send the CAN communication signal
		Diagnosis delay time	Continuously for 2 seconds or more

POSSIBLE CAUSE

Harness or connector (CAN communication line is open or shorted)

FAIL-SAFE

Not changed from normal driving

DTC CONFIRMATION PROCEDURE

1. PREPARATION BEFORE WORK

If another "DTC CONFIRMATION PROCEDURE" occurs just before, turn ignition switch OFF and wait for at least 10 seconds, then perform the next test.

>> GO TO 2.

2. CHECK DTC DETECTION

With CONSULT

1. Start the engine and wait for at least 5 seconds.
2. Check the DTC.

Is "U1000" detected?

- YES >> Go to [TM-94, "Diagnosis Procedure"](#).
- NO-1 >> To check malfunction symptom before repair: Refer to [GI-41, "Intermittent Incident"](#).
- NO-2 >> Confirmation after repair: INSPECTION END

Diagnosis Procedure

INFOID:000000012436452

For the diagnosis procedure, refer to [LAN-17, "Trouble Diagnosis Flow Chart"](#).

U1117 LOST COMMUNICATION (ABS)

< DTC/CIRCUIT DIAGNOSIS >

[CVT: RE0F10H]

U1117 LOST COMMUNICATION (ABS)

DTC Description

INFOID:000000012436453

DTC DETECTION LOGIC

When the ignition switch is ON, TCM is unable to receive the CAN communications signal from ABS actuator and electric unit (control unit) continuously for 2 seconds or more.

DTC	CONSULT screen terms (Trouble diagnosis content)	DTC detection condition	
		Diagnosis condition	Signal
U1117	LOST COMM (ABS) (Lost Communication With ABS)	Diagnosis condition	When the ignition switch is ON
		Signal	CAN communication signal
		Threshold	TCM is unable to receive the CAN communications signal from ABS actuator and electric unit (control unit)
		Diagnosis delay time	Continuously for 2 seconds or more

POSSIBLE CAUSE

- ABS actuator and electric unit (control unit)
- Harness or connector (CAN communication line is open or shorted)

FAIL-SAFE

Not changed from normal driving

DTC CONFIRMATION PROCEDURE

1. PREPARATION BEFORE WORK

If another "DTC CONFIRMATION PROCEDURE" occurs just before, turn ignition switch OFF and wait for at least 10 seconds, then perform the next test.

>> GO TO 2.

2. PERFORM DTC CONFIRMATION PROCEDURE

With CONSULT

1. Start the engine and wait for 5 seconds or more.
2. Check the DTC.

Is "U1117" detected?

YES >> Go to [TM-95, "Diagnosis Procedure"](#).

NO-1 >> To check malfunction symptom before repair: Refer to [GI-41, "Intermittent Incident"](#).

NO-2 >> Confirmation after repair: INSPECTION END

Diagnosis Procedure

INFOID:000000012436454

For the diagnosis procedure, refer to [LAN-17, "Trouble Diagnosis Flow Chart"](#).

P062F EEPROM

DTC Description

INFOID:000000012436455

TCM compares the calculated value stored in the flash ROM with the value stored in TCM. If the calculated value does not agree with the stored value, TCM judges this as a malfunction.

DTC DETECTION LOGIC

Flash ROM error is detected when turning ON the ignition switch.

DTC	CONSULT screen terms (Trouble diagnosis content)	DTC detection condition	
		Diagnosis condition	When turning ON the ignition switch
P062F	EEPROM (Internal Control Module EEPROM Error)	Signal	—
		Threshold	Flash ROM error
		Diagnosis delay time	—

POSSIBLE CAUSE

- TCM (Flash ROM)
- Harness or connector [TCM power supply (back-up) circuit is open or shorted]

FAIL-SAFE

Not changed from normal driving

DTC CONFIRMATION PROCEDURE

1. PREPARATION BEFORE WORK

If another "DTC CONFIRMATION PROCEDURE" occurs just before, turn ignition switch OFF and wait for at least 10 seconds, then perform the next test.

>> GO TO 2.

2. CHECK DTC DETECTION

1. Start the engine.
2. Check the DTC.

Is "P062F" detected?

- YES >> Go to [TM-96, "Diagnosis Procedure"](#).
- NO-1 >> To check malfunction symptom before repair: Refer to [GI-41, "Intermittent Incident"](#).
- NO-2 >> Confirmation after repair: INSPECTION END

Diagnosis Procedure

INFOID:000000012436456

1. CHECK TCM BATTERY POWER SUPPLY (BACK-UP) CIRCUIT

1. Turn ignition switch OFF.
2. Disconnect TCM connector.
3. Turn ignition switch ON.
4. Check voltage between TCM harness connector terminals and ground.

TCM		-	Voltage
Connector	Terminal		
F89	45	Ground	10 – 16 V
	46		

Is the inspection result normal?

- YES >> GO TO 2.
- NO >> Repair or replace malfunctioning parts.

2. DETECT MALFUNCTIONING ITEMS

P062F EEPROM

< DTC/CIRCUIT DIAGNOSIS >

[CVT: RE0F10H]

Check the following items:

- Open or short circuit of harness between battery positive terminal and TCM connector terminals 45, and 46.
- 10A fuse [No.60, located in the fuse, fusible link and relay box]. Refer to [PG-89, "Terminal Arrangement"](#).

Is the inspection result normal?

YES >> GO TO 3.

NO >> Repair or replace malfunctioning parts.

3.CHECK INTERMITTENT INCIDENT

Refer to [GI-41, "Intermittent Incident"](#).

Is the inspection result normal?

YES >> Replace the TCM. Refer to [TM-191, "Removal and Installation"](#).

NO >> Repair or replace malfunctioning parts.

A

B

C

TM

E

F

G

H

I

J

K

L

M

N

O

P

P0705 TRANSMISSION RANGE SENSOR A

< DTC/CIRCUIT DIAGNOSIS >

[CVT: RE0F10H]

P0705 TRANSMISSION RANGE SENSOR A

DTC Description

INFOID:000000012436457

DTC DETECTION LOGIC

DTC	CONSULT screen terms (Trouble diagnosis content)	DTC detection condition	
P0705	T/M RANGE SENSOR A [Transmission Range Sensor A Circuit (PRNDL Input)]	Diagnosis condition	TCM power supply voltage: More than 11 V
		Signal	Transmission range switch signal
		Threshold	Two or more range signals simultaneously stay ON continuously
		Diagnosis delay time	Maintained for 2 seconds

POSSIBLE CAUSE

- Harness or connector (Short circuit between transmission range switch and TCM)
- Transmission range switch

FAIL-SAFE

- Shift position indicator on combination meter is not displayed
- Selector shock is large
- Start is slow
- Acceleration is slow
- Lock-up is not performed

DTC CONFIRMATION PROCEDURE

1. PREPARATION BEFORE WORK

If another "DTC CONFIRMATION PROCEDURE" occurs just before, turn ignition switch OFF and wait for at least 10 seconds, then perform the next test.

>> GO TO 2.

2. CHECK DTC DETECTION

1. Turn ignition switch ON.
2. Shift the selector lever through entire positions from "P" to "D". (Hold the selector lever at each position for 5 seconds or more.)
3. Check the first trip DTC.

Is "P0705" detected?

YES >> Go to [TM-98, "Diagnosis Procedure"](#).

NO-1 >> To check malfunction symptom before repair: Refer to [GI-41, "Intermittent Incident"](#).

NO-2 >> Confirmation after repair: INSPECTION END

Diagnosis Procedure

INFOID:000000012436458

1. CHECK TCM INPUT SIGNALS

With CONSULT

1. Turn ignition switch ON.
2. Select "Data Monitor" in "TRANSMISSION".
3. Select "D POSITION SW", "N POSITION SW", "R POSITION SW", and "P POSITION SW".
4. Shift the selector lever through entire positions from "P" to "D" and check ON/OFF of each monitor item.

Monitor item	Test condition	Condition
D POSITION SW	Selector lever: "D" position	On
	Other than the above	Off

P0705 TRANSMISSION RANGE SENSOR A

< DTC/CIRCUIT DIAGNOSIS >

[CVT: RE0F10H]

Monitor item	Test condition	Condition
N POSITION SW	Selector lever: "N" position	On
	Other than the above	Off
R POSITION SW	Selector lever: "R" position	On
	Other than the above	Off
P POSITION SW	Selector lever: "P" position	On
	Other than the above	Off

⊗ Without CONSULT

1. Turn ignition switch OFF.
2. Disconnect TCM connector.
3. Turn ignition switch ON.
4. Shift the selector lever from "P" to "D" and check voltage between TCM harness connector terminals and ground.

+		-	Test condition	Voltage
TCM				
Connector	Terminal			
F89	4	Ground	Selector lever: "D" position	10 – 16 V
			Other than the above	Approx. 0 V
	5		Selector lever: "N" position	10 – 16 V
			Other than the above	Approx. 0 V
	6		Selector lever: "R" position	10 – 16 V
			Other than the above	Approx. 0 V
	7		Selector lever: "P" position	10 – 16 V
			Other than the above	Approx. 0 V

Is the inspection result normal?

YES >> Check intermittent incident. Refer to [GI-41, "Intermittent Incident"](#).

NO-1 ["D POSITION SW" is "ON" when selector is not in "D" position. (Or connector terminal 4 is at power voltage.)]>>GO TO 2.

NO-2 ["N POSITION SW" is "ON" when selector is not in "N" position. (Or connector terminal 5 is at power voltage.)]>>GO TO 4.

NO-3 ["R POSITION SW" is "ON" when selector is not in "R" position. (Or connector terminal 6 is at power voltage.)]>>GO TO 6.

NO-4 ["P POSITION SW" is "ON" when selector is not in "P" position. (Or connector terminal 7 is at power voltage.)]>>GO TO 8.

2.CHECK D POSITION SW CIRCUIT (PART 1)

1. Turn ignition switch OFF.
2. Disconnect TCM connector.
3. Check continuity between TCM harness connector terminals.

TCM			Continuity
Connector	Terminal		
F89	4	5	Not existed
		6	
		7	

Is the inspection result normal?

YES >> GO TO 3.

NO >> Repair or replace malfunctioning parts.

3.CHECK D POSITION SW CIRCUIT (PART 2)

A
B
C
TM
E
F
G
H
I
J
K
L
M
N
O
P

P0705 TRANSMISSION RANGE SENSOR A

[CVT: RE0F10H]

< DTC/CIRCUIT DIAGNOSIS >

1. Disconnect transmission range switch connector.
2. Turn ignition switch ON.
3. Check voltage between TCM harness connector terminal and ground.

+		-	Voltage (Approx.)
TCM			
Connector	Terminal		
F89	4	Ground	0 V

Is the inspection result normal?

YES >> GO TO 10.

NO >> Repair or replace malfunctioning parts.

4. CHECK N POSITION SW CIRCUIT (PART 1)

1. Turn ignition switch OFF.
2. Disconnect TCM connector.
3. Check continuity between TCM harness connector terminals.

TCM			Continuity
Connector	Terminal		
F89	5	4	Not existed
		6	
		7	

Is the inspection result normal?

YES >> GO TO 5.

NO >> Repair or replace malfunctioning parts.

5. CHECK N POSITION SW CIRCUIT (PART 2)

1. Disconnect transmission range switch connector.
2. Turn ignition switch ON.
3. Check voltage between TCM harness connector terminal and ground.

+		-	Voltage (Approx.)
TCM			
Connector	Terminal		
F89	5	Ground	0 V

Is the inspection result normal?

YES >> GO TO 10.

NO >> Repair or replace malfunctioning parts.

6. CHECK P POSITION SW CIRCUIT (PART 1)

1. Turn ignition switch OFF.
2. Disconnect TCM connector.
3. Check continuity between TCM harness connector terminals.

TCM			Continuity
Connector	Terminal		
F89	7	4	Not existed
		5	
		6	

Is the inspection result normal?

YES >> GO TO 7.

NO >> Repair or replace malfunctioning parts.

P0705 TRANSMISSION RANGE SENSOR A

< DTC/CIRCUIT DIAGNOSIS >

[CVT: RE0F10H]

7. CHECK P POSITION SW CIRCUIT (PART 2)

1. Disconnect transmission range switch connector.
2. Turn ignition switch ON.
3. Check voltage between TCM harness connector terminal and ground.

+		-	Voltage (Approx.)
TCM			
Connector	Terminal		
F89	7	Ground	0 V

Is the inspection result normal?

YES >> GO TO 10.

NO >> Repair or replace malfunctioning parts.

8. CHECK R POSITION SW CIRCUIT (PART1)

1. Turn ignition switch OFF.
2. Disconnect TCM connector.
3. Check continuity between TCM harness connector terminals.

TCM		Continuity
Connector	Terminal	
F89	6	4
		5
		7
		Not existed

Is the inspection result normal?

YES >> GO TO 9.

NO >> Repair or replace malfunctioning parts.

9. CHECK R POSITION SW CIRCUIT (PART 2)

1. Disconnect transmission range switch connector.
2. Turn ignition switch ON.
3. Check voltage between TCM harness connector terminal and ground.

+		-	Voltage (Approx.)
TCM			
Connector	Terminal		
F89	6	Ground	0 V

Is the inspection result normal?

YES >> GO TO 10.

NO >> Repair or replace malfunctioning parts.

10. CHECK TRANSMISSION RANGE SWITCH

Check transmission range switch. Refer to [TM-101, "Component Inspection"](#).

Is the check result normal?

YES >> Check intermittent incident. Refer to [GI-41, "Intermittent Incident"](#).

NO >> Repair or replace malfunctioning parts.

Component Inspection

INFOID:0000000012436459

1. CHECK TRANSMISSION RANGE SWITCH

Check continuity between transmission range switch connector terminals.

P0705 TRANSMISSION RANGE SENSOR A

< DTC/CIRCUIT DIAGNOSIS >

[CVT: RE0F10H]

Transmission range switch Terminal	Condition	Continuity
7 – 10	Manual lever: "P" and "N" positions	Existed
	Other than the above	Not existed
4 – 5	Manual lever: "P" position	Existed
	Other than the above	Not existed
4 – 8	Manual lever: "R" position	Existed
	Other than the above	Not existed
4 – 9	Manual lever: "N" position	Existed
	Other than the above	Not existed
4 – 2	Manual lever: "D" position	Existed
	Other than the above	Not existed

Is the inspection result normal?

YES >> INSPECTION END

NO >> There is a malfunction of transmission range switch. Replace transaxle assembly. Refer to [TM-212. "Removal and Installation"](#).

P0706 TRANSMISSION RANGE SENSOR A

< DTC/CIRCUIT DIAGNOSIS >

[CVT: RE0F10H]

P0706 TRANSMISSION RANGE SENSOR A

DTC Description

INFOID:000000012436460

DTC DETECTION LOGIC

DTC	CONSULT screen terms (Trouble diagnosis content)	DTC detection condition	
		Diagnosis condition	TCM power supply voltage: More than 11 V
P0706	T/M RANGE SENSOR A (Transmission Range Sensor A Circuit Range/Performance)	Signal	Transmission range switch signal
		Threshold	All range signals stay OFF
		Diagnosis delay time	Maintained for 30 seconds

POSSIBLE CAUSE

- Harness or connector (Open circuit between ignition switch and transmission range switch/open circuit between transmission range switch and TCM)
 - Transmission range switch
 - Control cable
- Harness or connector (CAN communication line is error)

FAIL-SAFE

- Shift position indicator on combination meter is not displayed
- Selector shock is large
- Start is slow
- Acceleration is slow
- Lock-up is not performed

DTC CONFIRMATION PROCEDURE

1. PREPARATION BEFORE WORK

If another "DTC CONFIRMATION PROCEDURE" occurs just before, turn ignition switch OFF and wait for at least 10 seconds, then perform the next test.

>> GO TO 2.

2. PERFORM DTC CONFIRMATION PROCEDURE

1. Turn ignition switch ON.
2. Shift the selector lever through entire positions from "P" to "D". (Hold the selector lever at each position for 40 seconds or more.)
3. Check the first trip DTC.

Is "P0706" detected?

- YES >> Go to [TM-103, "Diagnosis Procedure"](#).
- NO-1 >> To check malfunction symptom before repair: Refer to [GI-41, "Intermittent Incident"](#).
- NO-2 >> Confirmation after repair: INSPECTION END

Diagnosis Procedure

INFOID:000000012436461

1. ADJUSTMENT OF CONTROL CABLE

Adjust control cable. Refer to [TM-188, "Inspection and Adjustment"](#).

>> GO TO 2.

2. PERFORM DTC CONFIRMATION PROCEDURE

With CONSULT

1. Turn ignition switch ON.
2. Select "Self Diagnostic Results" in "TRANSMISSION".
3. Touch "Erase".
4. Perform "DTC CONFIRMATION PROCEDURE". Refer to [TM-103, "DTC Description"](#).

P0706 TRANSMISSION RANGE SENSOR A

< DTC/CIRCUIT DIAGNOSIS >

[CVT: RE0F10H]

Is "P0706" detected?

- YES >> GO TO 3.
- NO >> INSPECTION END

3. CHECK POWER CIRCUIT

1. Turn ignition switch OFF.
2. Disconnect transmission range switch connector.
3. Turn ignition switch ON.
4. Check voltage between transmission range switch harness connector terminal and ground.

+		-	Voltage
Connector	Terminal		
F86	4	Ground	10 – 16 V

Is the inspection result normal?

- YES >> GO TO 4.
- NO >> GO TO 7.

4. CHECK CIRCUIT BETWEEN TRANSMISSION RANGE SWITCH AND TCM (PART 1)

1. Turn ignition switch OFF.
2. Disconnect TCM connector.
3. Check continuity between transmission range switch harness connector terminals and TCM harness connector terminals.

Transmission range switch		TCM		Continuity
Connector	Terminal	Connector	Terminal	
F86	2	F89	4	Existed
	5		7	
	8		6	
	9		5	

Is the inspection result normal?

- YES >> GO TO 5.
- NO >> Repair or replace malfunctioning parts.

5. CHECK CIRCUIT BETWEEN TRANSMISSION RANGE SWITCH AND TCM (PART 2)

Check continuity between transmission range switch harness connector terminals and ground.

Transmission range switch		—	Continuity
Connector	Terminal		
F86	2	Ground	Not existed
	5		
	8		
	9		

Is the inspection result normal?

- YES >> GO TO 6.
- NO >> Repair or replace malfunctioning parts.

6. CHECK TRANSMISSION RANGE SWITCH

Check transmission range switch. Refer to [TM-105, "Component Inspection"](#).

Is the inspection result normal?

- YES >> Check intermittent incident. Refer to [GI-41, "Intermittent Incident"](#).
- NO >> Repair or replace malfunctioning parts.

P0706 TRANSMISSION RANGE SENSOR A

< DTC/CIRCUIT DIAGNOSIS >

[CVT: RE0F10H]

7. DETECT MALFUNCTIONING ITEMS

Check the following items:

- Harness open circuit or short circuit between ignition switch and IPDM E/R. Refer to [PG-40, "Wiring Diagram - IGNITION POWER SUPPLY -"](#).
- Harness open circuit or short circuit between IPDM E/R connector terminal 61 and transmission range switch connector terminal 4.
- 10A fuse (No.43, located in the IPDM E/R). Refer to [PG-91, "Fuse, Connector and Terminal Arrangement"](#).
- IPDM E/R

Is the check result normal?

- YES >> Check intermittent incident. Refer to [GI-41, "Intermittent Incident"](#).
- NO >> Repair or replace malfunctioning parts.

Component Inspection

INFOID:000000012436462

1. CHECK TRANSMISSION RANGE SWITCH

Check continuity between transmission range switch connector terminals.

Transmission range switch Terminal	Condition	Continuity
7 - 10	Manual lever: "P" and "N" positions	Existed
	Other than the above	Not existed
4 - 5	Manual lever: "P" position	Existed
	Other than the above	Not existed
4 - 8	Manual lever: "R" position	Existed
	Other than the above	Not existed
4 - 9	Manual lever: "N" position	Existed
	Other than the above	Not existed
4 - 2	Manual lever: "D" position	Existed
	Other than the above	Not existed

Is the inspection result normal?

- YES >> INSPECTION END
- NO >> There is a malfunction of transmission range switch. Replace transaxle assembly. Refer to [TM-212, "Removal and Installation"](#).

P0711 TRANSMISSION FLUID TEMPERATURE SENSOR A

< DTC/CIRCUIT DIAGNOSIS >

[CVT: RE0F10H]

P0711 TRANSMISSION FLUID TEMPERATURE SENSOR A

DTC Description

INFOID:000000012436463

DTC DETECTION LOGIC

DTC	CONSULT screen terms (Trouble diagnosis content)	DTC detection condition		
P0711	FLUID TEMP SENSOR A (Transmission Fluid Temperature Sensor A Circuit Range/Performance)	1	Diagnosis condition	When all of the following conditions are satisfied. <ul style="list-style-type: none"> • TCM power supply voltage: More than 11 V • CAN communication is normal • Engine speed: 450 rpm or more • Accelerator pedal position: 3 deg. or more • Vehicle speed: 10 km/h (7 MPH) or more • U0100, P0705 and P0706 are not detected. • Selector lever: "D" position
			Signal	CVT fluid temperature sensor signal
			Threshold	CVT fluid temperature does not rise to 10°C (50°F) after driving for a certain period of time with the TCM-received fluid temperature sensor value between -40°C (-40°F) and 9°C (48.2°F).
			Diagnosis delay time	—
		2	Diagnosis condition	All of the following conditions are satisfied within 2 seconds after the ignition switch is turned ON. <ul style="list-style-type: none"> • U0073, U0100, P0712 and P0713 are not detected. • CAN communication is normal. • TCM power supply voltage: More than 11 V • The difference between CVT fluid temperature and engine coolant temperature is 55°C (131°F) or more, or -27°C (-16°F) or less.
			Signal	CVT fluid temperature sensor signal
			Threshold	When all of the following conditions are satisfied <ul style="list-style-type: none"> • ECM is normal. • Diagnosis condition is satisfied.
			Diagnosis delay time	Maintained for 300 seconds

POSSIBLE CAUSE

CVT fluid temperature sensor

FAIL-SAFE

- Engine coolant temperature when engine start: Temp. $\geq 10^{\circ}\text{C}$ (50°F)
 - Start is slow
 - Acceleration is slow
- Engine coolant temperature when engine start: -35°C (-31°F) \leq Temp. $< 10^{\circ}\text{C}$ (50°F)
 - Selector shock is large
 - Start is slow
 - Acceleration is slow
- Engine coolant temperature when engine start: Temp. $< -35^{\circ}\text{C}$ (-31°F)
 - Selector shock is large
 - Start is slow
 - Acceleration is slow

DTC CONFIRMATION PROCEDURE

CAUTION:

P0711 TRANSMISSION FLUID TEMPERATURE SENSOR A

< DTC/CIRCUIT DIAGNOSIS >

[CVT: RE0F10H]

Always drive vehicle at a safe speed.

1. PREPARATION BEFORE WORK

If another "DTC CONFIRMATION PROCEDURE" occurs just before, turn ignition switch OFF and wait for at least 10 seconds, then perform the next test.

>> GO TO 2.

2. INSPECTION START

Is it necessary to erase permanent DTC?

YES >> GO TO 3.

NO >> GO TO 7.

3. CHECK DTC (ECM AND TCM)

Check the DTC.

Is any DTC other than "P0711" detected?

YES >> Check DTC detected item. Refer to [EC-107, "DTC Index"](#) (ECM), [TM-58, "DTC Index"](#) (TCM).

NO >> GO TO 4.

4. PERFORM DTC CONFIRMATION PROCEDURE (PART 1)

TESTING CONDITION:

- While performing the following procedure, do not add fuel.
- Before performing the following procedure, check that fuel level is between 1/4 and 4/4.
- Before performing the following procedure, confirm that battery voltage is 11 V or more at idle.

With CONSULT

1. Move the vehicle to a cool place.

NOTE:

Cool the vehicle in an environment of ambient air temperature between -10°C (14°F) and 35°C (95°F).

2. Turn ignition switch OFF and leave the vehicle for 12 hours.

CAUTION:

Never turn ignition switch ON during this procedure.

NOTE:

The vehicle must be cooled with the hood open.

3. Turn ignition switch ON.

CAUTION:

Never start the engine.

4. Select "Data Monitor" in "TRANSMISSION".
5. Select "FLUID TEMP".
6. Record CVT fluid temperature.
7. Start engine and let it idle for 5 minutes or more.

CAUTION:

Never turn ignition switch OFF during idling.

8. Check 1st trip DTC.

With GST

1. Move the vehicle to a cool place.

NOTE:

Cool the vehicle in an environment of ambient air temperature between -10°C (14°F) and 35°C (95°F).

2. Turn ignition switch OFF and leave the vehicle for 12 hours.

CAUTION:

Never turn ignition switch ON during this procedure.

NOTE:

The vehicle must be cooled with the hood open.

3. Start engine and let it idle for 5 minutes or more.

CAUTION:

Never turn ignition switch OFF during idling.

4. Check 1st trip DTC.

Is "P0711" detected?

YES >> Go to [TM-109, "Diagnosis Procedure"](#).

P0711 TRANSMISSION FLUID TEMPERATURE SENSOR A

< DTC/CIRCUIT DIAGNOSIS >

[CVT: RE0F10H]

NO-1 (With CONSULT)>>GO TO 5.

NO-2 (With GST)>>GO TO 6.

5. CHECK CVT FLUID TEMPERATURE

With CONSULT

1. Select "Data Monitor" in "TRANSMISSION".
2. Select "FLUID TEMP".

Is the value of "FLUID TEMP" 10°C (50°F) or more?

YES >> INSPECTION END

NO >> GO TO 6.

6. PERFORM DTC CONFIRMATION PROCEDURE (PART 2)

With CONSULT

1. Drive the vehicle for the total minutes specified in the Driving time column below with the following conditions satisfied.

Selector lever	: "D" position
Accelerator pedal position	: 1.0/8 or more
Vehicle speed	: 10 km/h (7 MPH) or more

CVT fluid temperature before engine start	Driving time
-40°C (-40°F) – -31°C (-23.8°F)	20 minutes or more
-30°C (-22°F) – -21°C (-5.8°F)	18 minutes or more
-20°C (-4°F) – -11°C (-12.2°F)	14 minutes or more
-10°C (14°F) – -1°C (30.2°F)	10 minutes or more
0°C (32°F) – 9°C (48.2°F)	7 minutes or more

2. Stop the vehicle.
3. Check the first trip DTC.

With GST

1. Drive the vehicle and maintain the following conditions for 20 minutes or more.

Selector lever	: "D" position
Accelerator pedal position	: 1.0/8 or more
Vehicle speed	: 10 km/h (7 MPH) or more

2. Stop the vehicle.
3. Check the first trip DTC.

Is "P0711" detected?

YES >> Go to [TM-109, "Diagnosis Procedure"](#).

NO-1 >> To check malfunction symptom before repair: Refer to [GI-41, "Intermittent Incident"](#).

NO-2 >> Confirmation after repair: INSPECTION END

7. PERFORM DTC CONFIRMATION PROCEDURE

With CONSULT

1. Turn ignition switch OFF and cool the engine.
2. Turn ignition switch ON.

CAUTION:

Never start the engine.

3. Select "Data Monitor" in "TRANSMISSION".
4. Select "FLUID TEMP".
5. Record CVT fluid temperature.
6. Start the engine and wait for at least 2 minutes.
7. Drive the vehicle for the total minutes specified in the Driving time column below with the following conditions satisfied.

P0711 TRANSMISSION FLUID TEMPERATURE SENSOR A

< DTC/CIRCUIT DIAGNOSIS >

[CVT: RE0F10H]

Selector lever : "D" position
Accelerator pedal position : 1.0/8 or more
Vehicle speed : 10 km/h (7 MPH) or more

CVT fluid temperature before engine start	Driving time
-40°C (-40°F) – -31°C (-23.8°F)	20 minutes or more
-30°C (-22°F) – -21°C (-5.8°F)	18 minutes or more
-20°C (-4°F) – -11°C (-12.2°F)	14 minutes or more
-10°C (14°F) – -1°C (30.2°F)	10 minutes or more
0°C (32°F) – 9°C (48.2°F)	7 minutes or more
Other than the above	— (Go to "8.CHECK CVT FLUID TEMPERATURE SENSOR")

8. Stop the vehicle.
9. Check the first trip DTC.

⊗ With GST

1. Turn ignition switch OFF and cool the engine.
2. Start the engine and wait for at least 2 minutes.
3. Drive the vehicle and maintain the following conditions for 20 minutes or more.

Selector lever : "D" position
Accelerator pedal position : 1.0/8 or more
Vehicle speed : 10 km/h (7 MPH) or more

4. Stop the vehicle.
- CAUTION:**
Never turn ignition switch OFF
5. Check the first trip DTC.

Is "P0711" detected?

YES >> Go to [TM-109, "Diagnosis Procedure"](#).
NO >> GO TO 8.

8.CHECK CVT FLUID TEMPERATURE SENSOR

1. Turn ignition switch OFF.
2. Disconnect CVT unit connector.
3. Check resistance between CVT unit connector terminals.

CVT unit Terminal	Condition	Resistance (Approx.)
12 – 18	CVT fluid temperature: 20°C (68°F)	6.5 kΩ
	CVT fluid temperature: 50°C (122°F)	2.2 kΩ
	CVT fluid temperature: 80°C (176°F)	0.87 kΩ

Is the inspection result normal?

YES-1 >> To check malfunction symptom before repair: Refer to [GI-41, "Intermittent Incident"](#).
YES-2 >> Confirmation after repair: INSPECTION END
NO >> There is a malfunction of CVT fluid temperature sensor. Replace transaxle assembly. Refer to [TM-212, "Removal and Installation"](#).

Diagnosis Procedure

INFOID:0000000012436464

1.CHECK CVT FLUID TEMPERATURE SENSOR

1. Turn ignition switch OFF.
2. Disconnect CVT unit connector.
3. Check resistance between CVT unit connector terminals.

P0711 TRANSMISSION FLUID TEMPERATURE SENSOR A

< DTC/CIRCUIT DIAGNOSIS >

[CVT: RE0F10H]

CVT unit		Condition	Resistance (Approx.)
Connector	Terminal		
F209	12 – 18	CVT fluid temperature: 20°C (68°F)	6.5 kΩ
		CVT fluid temperature: 50°C (122°F)	2.2 kΩ
		CVT fluid temperature: 80°C (176°F)	0.87 kΩ

Is the inspection result normal?

YES >> GO TO 2.

NO >> Replace transaxle assembly. Refer to [TM-212, "Removal and Installation"](#)

2. CHECK CIRCUIT BETWEEN TCM AND CVT UNIT (CVT FLUID TEMPERATURE SENSOR) (PART 1)

1. Disconnect the TCM connector.
2. Check continuity between TCM harness connector terminals and CVT unit harness connector terminals.

TCM		CVT unit		Continuity
Connector	Terminal	Connector	Terminal	
F89	11	F43	18	Existed
	12		12	

Is the inspection result normal?

YES >> GO TO 3.

NO >> Repair or replace damaged parts.

3. CHECK CIRCUIT BETWEEN TCM AND CVT UNIT (CVT FLUID TEMPERATURE SENSOR) (PART 2)

Check continuity between TCM harness connector terminals and ground.

TCM		—	Continuity
Connector	Terminal		
F89	11	Ground	Not existed
	12		

Is the inspection result normal?

YES >> Check intermittent incident. Refer to [GI-41, "Intermittent Incident"](#).

NO >> Repair or replace damaged parts.

P0712 TRANSMISSION FLUID TEMPERATURE SENSOR A

< DTC/CIRCUIT DIAGNOSIS >

[CVT: RE0F10H]

P0712 TRANSMISSION FLUID TEMPERATURE SENSOR A

DTC Description

INFOID:000000012436465

DTC DETECTION LOGIC

DTC	CONSULT screen terms (Trouble diagnosis content)	DTC detection condition	
P0712	FLUID TEMP SENSOR A (Transmission Fluid Temperature Sensor A Circuit Low)	Diagnosis condition	TCM power supply voltage: More than 11 V
		Signal	CVT fluid temperature sensor signal
		Threshold	Fluid temperature sensor detection voltage: 0.15 V or less
		Diagnosis delay time	Maintained for 5 seconds

POSSIBLE CAUSE

- Harness or connector (CVT fluid temperature sensor circuit is shorted to ground)
- CVT fluid temperature sensor

FAIL-SAFE

- Engine coolant temperature when engine start: Temp. $\geq 10^{\circ}\text{C}$ (50°F)
 - Start is slow
 - Acceleration is slow
- Engine coolant temperature when engine start: -35°C (-31°F) \leq Temp. $< 10^{\circ}\text{C}$ (50°F)
 - Selector shock is large
 - Start is slow
 - Acceleration is slow
- Engine coolant temperature when engine start: Temp. $< -35^{\circ}\text{C}$ (-31°F)
 - Selector shock is large
 - Start is slow
 - Acceleration is slow

DTC CONFIRMATION PROCEDURE

1. PREPARATION BEFORE WORK

If another "DTC CONFIRMATION PROCEDURE" occurs just before, turn ignition switch OFF and wait for at least 10 seconds, then perform the next test.

>> GO TO 2.

2. PERFORM DTC CONFIRMATION PROCEDURE

1. Start the engine and wait for 10 seconds or more.
2. Check the first trip DTC.

Is "P0712" detected?

- YES >> Go to [TM-111, "Diagnosis Procedure"](#).
- NO-1 >> To check malfunction symptom before repair: Refer to [GI-41, "Intermittent Incident"](#).
- NO-2 >> Confirmation after repair: INSPECTION END

Diagnosis Procedure

INFOID:000000012436466

1. CHECK CIRCUIT BETWEEN TCM AND CVT UNIT

1. Turn ignition switch OFF.
2. Disconnect TCM connector and CVT unit connector.
3. Check continuity between TCM harness connector terminal and ground.

TCM		—	Continuity
Connector	Terminal		
F89	12	Ground	Not existed

P0712 TRANSMISSION FLUID TEMPERATURE SENSOR A

< DTC/CIRCUIT DIAGNOSIS >

[CVT: RE0F10H]

Is the inspection result normal?

YES >> GO TO 2.

NO >> Repair or replace malfunctioning part.

2. CHECK TERMINAL CODE ASSEMBLY

Check continuity between CVT unit connector terminal and ground

CVT unit		—	Continuity
Connector	Terminal		
F209	12	Ground	Not existed

Is the inspection result normal?

YES >> GO TO 3.

NO >> Replace transaxle assembly. Refer to [TM-212, "Removal and Installation"](#).

3. CHECK CVT FLUID TEMPERATURE SENSOR

Check resistance between CVT unit connector terminals.

CVT unit		Condition	Resistance (Approx.)
Connector	Terminal		
F209	12 – 18	CVT fluid temperature: 20°C (68°F)	6.5 kΩ
		CVT fluid temperature: 50°C (122°F)	2.2 kΩ
		CVT fluid temperature: 80°C (176°F)	0.87 kΩ

Is the inspection result normal?

YES >> Check intermittent incident. Refer to [GI-41, "Intermittent Incident"](#).

NO >> Replace transaxle assembly. Refer to [TM-212, "Removal and Installation"](#).

P0713 TRANSMISSION FLUID TEMPERATURE SENSOR A

< DTC/CIRCUIT DIAGNOSIS >

[CVT: RE0F10H]

P0713 TRANSMISSION FLUID TEMPERATURE SENSOR A

DTC Description

INFOID:000000012436467

DTC DETECTION LOGIC

DTC	CONSULT screen terms (Trouble diagnosis content)	DTC detection condition	
P0713	FLUID TEMP SENSOR A (Transmission Fluid Temperature Sensor A Circuit High)	Diagnosis condition	When all of the following conditions are satisfied: <ul style="list-style-type: none">• TCM power supply voltage: More than 11 V• Vehicle speed: More than 10 km/h (7 MPH)
		Signal	CVT fluid temperature sensor signal
		Threshold	Fluid temperature sensor detection voltage: 2.48 V or more
		Diagnosis delay time	Maintained for 5 seconds

POSSIBLE CAUSE

- Harness or connector (CVT fluid temperature sensor circuit is open or shorted to power supply)
- CVT fluid temperature sensor

FAIL-SAFE

- Engine coolant temperature when engine start: Temp. $\geq 10^{\circ}\text{C}$ (50°F)
 - Start is slow
 - Acceleration is slow
- Engine coolant temperature when engine start: -35°C (-31°F) \leq Temp. $< 10^{\circ}\text{C}$ (50°F)
 - Selector shock is large
 - Start is slow
 - Acceleration is slow
- Engine coolant temperature when engine start: Temp. $< -35^{\circ}\text{C}$ (-31°F)
 - Selector shock is large
 - Start is slow
 - Acceleration is slow

DTC CONFIRMATION PROCEDURE

1. PREPARATION BEFORE WORK

If another "DTC CONFIRMATION PROCEDURE" occurs just before, turn ignition switch OFF and wait for at least 10 seconds, then perform the next test.

>> GO TO 2.

2. PERFORM DTC CONFIRMATION PROCEDURE

1. Start the engine.
2. Maintain the following condition for 10 seconds or more.

Vehicle speed : 20 km/h (12 MPH) or more

3. Stop the vehicle.
4. Check the first trip DTC.

Is "P0713" detected?

YES >> Go to [TM-113, "Diagnosis Procedure"](#).

NO-1 >> To check malfunction symptom before repair: Refer to [GI-41, "Intermittent Incident"](#).

NO-2 >> Confirmation after repair: INSPECTION END

Diagnosis Procedure

INFOID:000000012436468

1. CHECK CIRCUIT BETWEEN TCM AND CVT UNIT (PART 1)

1. Turn ignition switch OFF.

P0713 TRANSMISSION FLUID TEMPERATURE SENSOR A

< DTC/CIRCUIT DIAGNOSIS >

[CVT: RE0F10H]

2. Disconnect TCM connector and CVT unit connector.
3. Check continuity between TCM harness connector terminals and CVT unit harness connector terminals.

TCM		CVT unit		Continuity
Connector	Terminal	Connector	Terminal	
F89	11	F43	18	Existed
	12		12	

Is the inspection result normal?

YES >> GO TO 2.

NO >> Repair or replace malfunctioning parts.

2. CHECK CIRCUIT BETWEEN TCM AND CVT UNIT (PART 2)

1. Turn ignition switch ON.
2. Check voltage between TCM harness connector terminal and ground.

+		-	Voltage (Approx.)
TCM			
Connector	Terminal		
F89	12	Ground	0 V

Is the inspection result normal?

YES >> GO TO 3.

NO >> Repair or replace malfunctioning parts.

3. CHECK CVT FLUID TEMPERATURE SENSOR

1. Turn ignition switch OFF.
2. Check resistance between CVT unit connector terminals.

CVT unit		Condition	Resistance (Approx.)
Connector	Terminal		
F209	12 – 18	CVT fluid temperature: 20°C (68°F)	6.5 kΩ
		CVT fluid temperature: 50°C (122°F)	2.2 kΩ
		CVT fluid temperature: 80°C (176°F)	0.87 kΩ

Is the inspection result normal?

YES >> Check intermittent incident. Refer to [GI-41. "Intermittent Incident"](#).

NO >> Replace transaxle assembly. Refer to [TM-212. "Removal and Installation"](#).

P0715 INPUT SPEED SENSOR A

< DTC/CIRCUIT DIAGNOSIS >

[CVT: RE0F10H]

P0715 INPUT SPEED SENSOR A

DTC Description

INFOID:000000012436469

DTC DETECTION LOGIC

DTC	CONSULT screen terms (Trouble diagnosis content)	DTC detection condition	
P0715	INPUT SPEED SENSOR A (Input/Turbine Speed Sensor A Circuit)	Diagnosis condition	When any of 1, 2 or 3 is satisfied: <ol style="list-style-type: none"> 1. When all of the following conditions are satisfied and this state is maintained for 5 seconds: <ul style="list-style-type: none"> - Primary pulley speed: Less than 150 rpm - Secondary pulley speed: 500 rpm or more 2. When all of the following conditions are satisfied and this state is maintained for 0.5 seconds: <ul style="list-style-type: none"> - 10-msec-ago primary pulley speed: 1,000 rpm or more - Now primary pulley speed: 0 rpm 3. When all of the following conditions are satisfied and this state is maintained for 5 seconds: <ul style="list-style-type: none"> - Range: D or L - Engine speed: 450 rpm or more - Input speed: 300 rpm or more - Primary pulley speed: 300 rpm or more - Secondary pulley speed: 300 rpm or more - Differences between engine speed and primary pulley speed: More than 1,000 rpm - Differences between primary pulley speed and input speed: More than 1,000 rpm - Differences between engine speed and input speed: 1,000 rpm or less - Lock-up command is being given (except for slip lock-up) - DTC other than the applicable DTC is not detected.
		Signal	—
		Threshold	When the following conditions are satisfied: <ul style="list-style-type: none"> • TCM power supply voltage: More than 11 V • After range change completion, it spends 2 seconds or more.
		Diagnosis delay time	—

POSSIBLE CAUSE

- Harness or connector (Primary speed sensor circuit is open or shorted)
- Primary speed sensor

FAIL-SAFE

- Start is slow
- Acceleration is slow
- Lock-up is not performed
- Manual mode is not activated

DTC CONFIRMATION PROCEDURE

CAUTION:

Be careful of the driving speed.

P0715 INPUT SPEED SENSOR A

< DTC/CIRCUIT DIAGNOSIS >

[CVT: RE0F10H]

1. PREPARATION BEFORE WORK

If another "DTC CONFIRMATION PROCEDURE" occurs just before, turn ignition switch OFF and wait for at least 10 seconds, then perform the next test.

>> GO TO 2.

2. CHECK DTC DETECTION

1. Start the engine.
2. Drive the vehicle.
3. Maintain the following conditions for 10 seconds or more.

Selector lever : "D" POSITION
Engine speed : 1,200 rpm or more
Vehicle speed : 40 km/h (25 MPH) or more

4. Stop the vehicle.
5. Check the first trip DTC.

Is "P0715" detected?

YES >> Go to [TM-116, "Diagnosis Procedure"](#).

NO-1 >> To check malfunction symptom before repair: Refer to [GI-41, "Intermittent Incident"](#).

NO-2 >> Confirmation after repair: INSPECTION END

Diagnosis Procedure

INFOID:0000000012436470

1. CHECK PRIMARY SPEED SENSOR POWER CIRCUIT

1. Turn ignition switch OFF.
2. Disconnect primary speed sensor connector.
3. Turn ignition switch ON.
4. Check voltage between primary speed sensor harness connector terminal and ground.

+		-	Voltage
Connector	Terminal		
F84	3	Ground	10 – 16 V

Is the inspection result normal?

YES >> GO TO 2.

NO >> GO TO 6.

2. CHECK PRIMARY SPEED SENSOR GROUND CIRCUIT

Check continuity between primary speed sensor harness connector terminal and ground.

Primary speed sensor		—	Continuity
Connector	Terminal		
F84	1	Ground	Existed

Is the inspection result normal?

YES >> GO TO 3.

NO >> Repair or replace malfunctioning parts.

3. CHECK CIRCUIT BETWEEN PRIMARY SPEED SENSOR AND TCM (PART 1)

1. Turn ignition switch OFF.
2. Disconnect TCM connector.
3. Check continuity between primary speed sensor harness connector terminal and TCM harness connector terminal.

P0715 INPUT SPEED SENSOR A

< DTC/CIRCUIT DIAGNOSIS >

[CVT: RE0F10H]

Primary speed sensor		TCM		Continuity
Connector	Terminal	Connector	Terminal	
F84	2	F89	35	Existed

Is the inspection result normal?

- YES >> GO TO 4.
- NO >> Repair or replace malfunctioning parts.

4.CHECK CIRCUIT BETWEEN PRIMARY SPEED SENSOR AND TCM (PART 2)

Check continuity between primary speed sensor harness connector terminal and ground.

Primary speed sensor		—	Continuity
Connector	Terminal		
F84	2	Ground	Not existed

Is the inspection result normal?

- YES >> GO TO 5.
- NO >> Repair or replace malfunctioning parts.

5.CHECK TCM INPUT SIGNALS

1. Connect all of disconnected connectors.
2. Lift the vehicle.
3. Start the engine.
4. Check frequency of primary speed sensor.

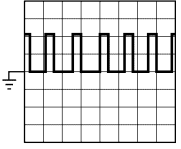
+		-	Condition	Frequency (Approx.)
TCM				
Connector	Terminal			
F89	35	Ground	<ul style="list-style-type: none"> • Selector lever: "M1" position • Vehicle speed: 20 km/h (12 MPH) 	<p>600 Hz</p> <p>1mSec/div</p>  <p>5V/div</p> <p>JSDIA3770GB</p>

Is the inspection result normal?

- YES >> Check intermittent incident. Refer to [GI-41, "Intermittent Incident"](#).
- NO >> Replace primary speed sensor. Refer to [TM-202, "Removal and Installation"](#).

6.DETECT MALFUNCTIONING ITEMS

Check the following items:

- Harness open circuit or short circuit between ignition switch and IPDM E/R. Refer to [PG-40, "Wiring Diagram - IGNITION POWER SUPPLY -"](#).
- Harness open circuit or short circuit between IPDM E/R connector terminal 61 and primary speed sensor connector terminal 3.
- 10A fuse (No.43, located in the IPDM E/R). Refer to [PG-91, "Fuse, Connector and Terminal Arrangement"](#).
- IPDM E/R

Is the check result normal?

- YES >> Check intermittent incident. Refer to [GI-41, "Intermittent Incident"](#).
- NO >> Repair or replace malfunctioning parts.

P0717 INPUT SPEED SENSOR A

< DTC/CIRCUIT DIAGNOSIS >

[CVT: RE0F10H]

P0717 INPUT SPEED SENSOR A

DTC Description

INFOID:000000012436471

DTC DETECTION LOGIC

DTC	CONSULT screen terms (Trouble diagnosis content)	DTC detection condition	
P0717	INPUT SPEED SENSOR A (Input/Turbine Speed Sensor "A" Circuit No Signal)	Diagnosis condition	When any of 1, 2 or 3 is satisfied: 1. When all of the following conditions are satisfied and this state is maintained for 5 seconds: - Primary pulley speed: 500 rpm or more - Input speed: Less than 150 rpm - Range: Other than P, N - P0715 is not detected 2. When all of the following conditions are satisfied and this state is maintained for 0.5 seconds: - 10-msec-ago input speed: 1,000 rpm or more - Now input speed: 0 rpm 3. When all of the following conditions are satisfied and this state is maintained for 5 seconds: - Range: D or L - Engine speed: 450 rpm or more - Input speed: 300 rpm or more - Primary pulley speed: 300 rpm or more - Secondary pulley speed: 300 rpm or more - Differences between engine speed and primary pulley speed: 1,000 rpm or less - Differences between primary pulley speed and input speed: More than 1,000 rpm - Differences between engine speed and input speed: More than 1,000 rpm - Lock-up command is being given (except for slip lock-up) - DTC other than the applicable DTC is not detected.
		Signal	—
		Threshold	When the following conditions are satisfied: • TCM power supply voltage: More than 11 V • After range change completion, it spends 2 seconds or more.
		Diagnosis delay time	—

POSSIBLE CAUSE

- Harness or connector (Input speed sensor circuit is open or shorted)
- Input speed sensor

FAIL-SAFE

- Start is slow
- Acceleration is slow
- Lock-up is not performed

DTC CONFIRMATION PROCEDURE

CAUTION:

Always drive vehicle at a safe speed.

1. PREPARATION BEFORE WORK

P0717 INPUT SPEED SENSOR A

< DTC/CIRCUIT DIAGNOSIS >

[CVT: RE0F10H]

If another "DTC CONFIRMATION PROCEDURE" occurs just before, turn ignition switch OFF and wait for at least 10 seconds, then perform the next test.

>> GO TO 2.

2.CHECK DTC DETECTION

With CONSULT

1. Start the engine.
2. Drive the vehicle.
3. Maintain the following conditions for 10 seconds or more.

Selector lever : "D" position
Engine speed : 1,200 rpm or more
Vehicle speed : 40 km/h (25 MPH) or more

4. Stop the vehicle.
5. Check the first trip DTC.

Is "P0717" detected?

YES >> Go to [TM-119, "Diagnosis Procedure"](#).

NO-1 >> To check malfunction symptom before repair: Refer to [GI-41, "Intermittent Incident"](#).

NO-2 >> Confirmation after repair: INSPECTION END

Diagnosis Procedure

INFOID:000000012436472

1.CHECK INPUT SPEED SENSOR POWER CIRCUIT

1. Turn ignition switch OFF.
2. Disconnect input speed sensor connector.
3. Turn ignition switch ON.
4. Check voltage between input speed sensor harness connector terminal and ground.

+		-	Voltage
Connector	Terminal		
F85	3	Ground	10 – 16 V

Is the inspection result normal?

YES >> GO TO 2.

NO >> GO TO 6.

2.CHECK INPUT SPEED SENSOR GROUND CIRCUIT

Check continuity between input speed sensor harness connector terminal and ground.

Input speed sensor		—	Continuity
Connector	Terminal		
F85	1	Ground	Existed

Is the inspection result normal?

YES >> GO TO 3.

NO >> Repair or replace malfunctioning parts.

3.CHECK CIRCUIT BETWEEN INPUT SPEED SENSOR AND TCM (PART 1)

1. Turn ignition switch OFF.
2. Disconnect TCM connector.
3. Check continuity between input speed sensor harness connector terminal and TCM harness connector terminal.

P0717 INPUT SPEED SENSOR A

< DTC/CIRCUIT DIAGNOSIS >

[CVT: RE0F10H]

Input speed sensor		TCM		Continuity
Connector	Terminal	Connector	Terminal	
F85	2	F89	24	Existed

Is the inspection result normal?

- YES >> GO TO 4.
- NO >> Repair or replace malfunctioning parts.

4. CHECK CIRCUIT BETWEEN INPUT SPEED SENSOR AND TCM (PART 2)

Check continuity between input speed sensor harness connector terminal and ground.

Input speed sensor		—	Continuity
Connector	Terminal		
F85	2	Ground	Not existed

Is the inspection result normal?

- YES >> GO TO 5.
- NO >> Repair or replace malfunctioning parts.

5. CHECK TCM INPUT SIGNALS

1. Connect all of disconnected connectors.
2. Lift the vehicle.
3. Start the engine.
4. Check frequency of input speed sensor.

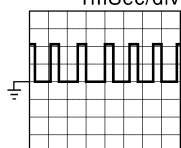
+		-	Condition	Frequency (Approx.)
TCM				
Connector	Terminal			
F89	24	Ground	<ul style="list-style-type: none"> • Selector lever: "M1" position • Vehicle speed: 20 km/h (12 MPH) 	<p>800 Hz</p> <p>1mSec/div</p>  <p>5V/div JSDIA3770GB</p>

Is the inspection result normal?

- YES >> Check intermittent incident. Refer to [GI-41, "Intermittent Incident"](#).
- NO >> Replace input speed sensor. Refer to [TM-201, "Removal and Installation"](#).

6. DETECT MALFUNCTIONING ITEMS

Check the following items:

- Harness open circuit or short circuit between ignition switch and IPDM E/R. Refer to [PG-40, "Wiring Diagram - IGNITION POWER SUPPLY -"](#).
- Harness open circuit or short circuit between IPDM E/R connector terminal 61 and input speed sensor connector terminal 3.
- 10A fuse (No.43, located in the IPDM E/R). Refer to [PG-91, "Fuse, Connector and Terminal Arrangement"](#).
- IPDM E/R

Is the check result normal?

- YES >> Check intermittent incident. Refer to [GI-41, "Intermittent Incident"](#).
- NO >> Repair or replace malfunctioning parts.

P0740 TORQUE CONVERTER

< DTC/CIRCUIT DIAGNOSIS >

[CVT: RE0F10H]

P0740 TORQUE CONVERTER

DTC Description

INFOID:0000000012436473

DTC DETECTION LOGIC

DTC	CONSULT screen terms (Trouble diagnosis content)	DTC detection condition	
P0740	TORQUE CONVERTER (Torque Converter Clutch Circuit/Open)	Diagnosis condition	When all of the following conditions are satisfied: • TCM power supply voltage: More than 11 V • P0743 is not detected
		Signal	—
		Threshold	TCM judges that solenoid valve circuit is open
		Diagnosis delay time	Maintained for 5 seconds

POSSIBLE CAUSE

- Harness or connector (Torque converter clutch solenoid valve circuit is open or shorted to power supply)
- Torque converter clutch solenoid valve

FAIL-SAFE

- Start is slow
- Acceleration is slow
- Lock-up is not performed

DTC CONFIRMATION PROCEDURE

CAUTION:

Be careful of the driving speed.

1. PREPARATION BEFORE WORK

If another "DTC CONFIRMATION PROCEDURE" occurs just before, turn ignition switch OFF and wait for at least 10 seconds, then perform the next test.

>> GO TO 2.

2. PREPARATION BEFORE OPERATION

With CONSULT

1. Start the engine.
2. Select "Data Monitor" in "TRANSMISSION".
3. Select "FLUID TEMP".
4. Confirm that the CVT fluid temperature is in the following range.

FLUID TEMP : 20°C (68°F) or more

With GST

1. Start the engine.
2. Set the CVT fluid to 20°C (68°F) or more.

NOTE:

When the ambient temperature is 20°C (68°F), the CVT fluid usually increases to 50 to 80°C (122 to 176°F) with driving in an urban area for approximately 10 minutes.

Is the CVT fluid 20°C (68°F) or more?

YES >> GO TO 3.

- NO >> 1. Warm the transaxle.
2. GO TO 3.

3. CHECK DTC DETECTION

1. Drive the vehicle.
2. Maintain the following conditions for 10 seconds or more.

P0740 TORQUE CONVERTER

< DTC/CIRCUIT DIAGNOSIS >

[CVT: RE0F10H]

Selector lever : "D" position
Vehicle speed : 40 km/h (25 MPH) or more

3. Stop the vehicle.
4. Check the first trip DTC.

Is "P0740" detected?

- YES >> Go to [TM-122, "Diagnosis Procedure"](#).
NO-1 >> To check malfunction symptom before repair: Refer to [GI-41, "Intermittent Incident"](#).
NO-2 >> Confirmation after repair: INSPECTION END

Diagnosis Procedure

INFOID:000000012436474

1. CHECK CIRCUIT BETWEEN TCM AND CVT UNIT

1. Turn ignition switch OFF.
2. Disconnect TCM connector and CVT unit connector.
3. Check continuity between TCM harness connector terminal and CVT unit harness connector terminal.

TCM		CVT unit		Continuity
Connector	Terminal	Connector	Terminal	
F89	38	F43	5	Existed

Is the inspection result normal?

- YES >> GO TO 2.
NO >> Repair or replace malfunctioning parts.

2. CHECK TORQUE CONVERTER CLUTCH SOLENOID VALVE CIRCUIT

Check resistance between CVT unit harness connector terminal and ground.

CVT unit		—	Condition	Resistance
Connector	Terminal			
F209	5	Ground	CVT fluid temperature: 20°C (68°F)	5.5 – 7.0 Ω
			CVT fluid temperature: 50°C (122°F)	6.0 – 8.0 Ω
			CVT fluid temperature: 80°C (176°F)	6.5 – 8.5 Ω

Is the inspection result normal?

- YES >> Check intermittent incident. Refer to [GI-41, "Intermittent Incident"](#).
NO >> There is malfunction of torque converter clutch solenoid valve circuit. Replace transaxle assembly. Refer to [TM-212, "Removal and Installation"](#).

P0743 TORQUE CONVERTER

< DTC/CIRCUIT DIAGNOSIS >

[CVT: RE0F10H]

P0743 TORQUE CONVERTER

DTC Description

INFOID:000000012436475

DTC DETECTION LOGIC

DTC	CONSULT screen terms (Trouble diagnosis content)	DTC detection condition	
		Diagnosis condition	TCM power supply voltage: More than 11 V
P0743	TORQUE CONVERTER (Torque Converter Clutch Circuit Electrical)	Signal	—
		Threshold	TCM judges that solenoid valve circuit is shorted to ground
		Diagnosis delay time	Maintained for 1 second

POSSIBLE CAUSE

- Harness or connector (Torque converter clutch solenoid valve circuit is shorted to ground)
- Torque converter clutch solenoid valve

FAIL-SAFE

- Start is slow
- Acceleration is slow
- Lock-up is not performed

DTC CONFIRMATION PROCEDURE

CAUTION:

Be careful of the driving speed.

1. PREPARATION BEFORE WORK

If another "DTC CONFIRMATION PROCEDURE" occurs just before, turn ignition switch OFF and wait for at least 10 seconds, then perform the next test.

>> GO TO 2.

2. PREPARATION BEFORE OPERATION

With CONSULT

1. Start the engine.
2. Select "Data Monitor" in "TRANSMISSION".
3. Select "FLUID TEMP".
4. Confirm that the CVT fluid temperature is in the following range.

FLUID TEMP : 20°C (68°F) or more

With GST

1. Start the engine.
2. Set the CVT fluid to 20°C (68°F) or more.

NOTE:

When the ambient temperature is 20°C (68°F), the CVT fluid usually increases to 50 to 80°C (122 to 176°F) with driving in an urban area for approximately 10 minutes.

Is the CVT fluid 20°C (68°F) or more?

YES >> GO TO 3.

NO >> 1. Warm the transaxle.
2. GO TO 3.

3. CHECK DTC DETECTION

1. Drive the vehicle.
2. Maintain the following conditions for 10 seconds or more.

Selector lever : "D" position

Vehicle speed : 40 km/h (25 MPH) or more

P0743 TORQUE CONVERTER

[CVT: RE0F10H]

< DTC/CIRCUIT DIAGNOSIS >

3. Stop the vehicle.
4. Check the first trip DTC.

Is "P0743" detected?

- YES >> Go to [TM-124, "Diagnosis Procedure"](#).
NO-1 >> To check malfunction symptom before repair: Refer to [GI-41, "Intermittent Incident"](#).
NO-2 >> Confirmation after repair: INSPECTION END

Diagnosis Procedure

INFOID:000000012436476

1. CHECK CIRCUIT BETWEEN TCM AND CVT UNIT

1. Turn ignition switch OFF.
2. Disconnect TCM connector and CVT unit connector.
3. Check continuity between TCM harness connector terminal and ground.

TCM		—	Continuity
Connector	Terminal		
F89	38	Ground	Not existed

Is the inspection result normal?

- YES >> GO TO 2.
NO >> Repair or replace malfunctioning parts.

2. CHECK TORQUE CONVERTER CLUTCH SOLENOID VALVE CIRCUIT

Check resistance between CVT unit harness connector terminal and ground.

CVT unit		—	Condition	Resistance
Connector	Terminal			
F209	5	Ground	CVT fluid temperature: 20°C (68°F)	5.5 – 7.0 Ω
			CVT fluid temperature: 50°C (122°F)	6.0 – 8.0 Ω
			CVT fluid temperature: 80°C (176°F)	6.5 – 8.5 Ω

Is the inspection result normal?

- YES >> Check intermittent incident. Refer to [GI-41, "Intermittent Incident"](#).
NO >> There is malfunction of torque converter clutch solenoid valve circuit. Replace transaxle assembly. Refer to [TM-212, "Removal and Installation"](#).

P0744 TORQUE CONVERTER

< DTC/CIRCUIT DIAGNOSIS >

[CVT: RE0F10H]

P0744 TORQUE CONVERTER

DTC Description

INFOID:000000012436477

DTC DETECTION LOGIC

DTC	CONSULT screen terms (Trouble diagnosis content)	DTC detection condition	
P0744	TORQUE CONVERTER (Torque converter clutch circuit intermittent)	Diagnosis condition	When all of the following conditions are satisfied: <ul style="list-style-type: none">• TCM power supply voltage: More than 11 V• P0717 is not detected.• CAN communication is normal• Torque converter slip speed: (40+vehicle speed/2) rpm
		Signal	—
		Threshold	LU pressure: More than 0.2 MPa
		Diagnosis delay time	Maintained for 30 seconds

POSSIBLE CAUSE

- Torque converter clutch solenoid valve
- Control valve assembly
- Torque converter

FAIL-SAFE

- Start is slow
- Acceleration is slow
- Lock-up is not performed

DTC CONFIRMATION PROCEDURE

CAUTION:

Be careful of the driving speed.

1. PREPARATION BEFORE WORK

If another "DTC CONFIRMATION PROCEDURE" occurs just before, turn ignition switch OFF and wait for at least 10 seconds, then perform the next test.

>> GO TO 2.

2. PREPARATION BEFORE OPERATION

With CONSULT

1. Start the engine.
2. Select "Data Monitor" in "TRANSMISSION".
3. Select "FLUID TEMP".
4. Confirm that the CVT fluid temperature is in the following range.

FLUID TEMP : 20°C (68°F) or more

With GST

1. Start the engine.
2. Set the CVT fluid to 20°C (68°F) or more.

NOTE:

When the ambient temperature is 20°C (68°F), the CVT fluid usually increases to 50 to 80°C (122 to 176°F) with driving in an urban area for approximately 10 minutes.

Is the CVT fluid 20°C (68°F) or more?

- YES >> GO TO 3.
NO >> 1. Warm the transaxle.
2. GO TO 3.

3. CHECK DTC DETECTION

P0744 TORQUE CONVERTER

[CVT: RE0F10H]

< DTC/CIRCUIT DIAGNOSIS >

1. Drive the vehicle.
2. Maintain the following conditions for 30 seconds or more.

Selector lever : "D" position
Accelerator pedal position : 0.5/8 or more
Vehicle speed : 40 km/h (25 MPH) or more

3. Stop the vehicle.
4. Check the first trip DTC.

Is "P0744" detected?

- YES >> Go to [TM-126. "Diagnosis Procedure"](#).
NO-1 >> To check malfunction symptom before repair: Refer to [GI-41. "Intermittent Incident"](#).
NO-2 >> Confirmation after repair: INSPECTION END

Diagnosis Procedure

INFOID:000000012436478

1. CHECK INTERMITTENT INCIDENT

Refer to [GI-41. "Intermittent Incident"](#).

Is the inspection result normal?

- YES >> Replace transaxle assembly. Refer to [TM-212. "Removal and Installation"](#).
NO >> Repair or replace the malfunction items.

P0746 PRESSURE CONTROL SOLENOID A

< DTC/CIRCUIT DIAGNOSIS >

[CVT: RE0F10H]

P0746 PRESSURE CONTROL SOLENOID A

DTC Description

INFOID:000000012436479

DTC DETECTION LOGIC

DTC	CONSULT screen terms (Trouble diagnosis content)	DTC detection condition		
P0746	PC SOLENOID A (Pressure Control Solenoid A Performance/Stuck Off)	1	Diagnosis condition	When all of the following conditions are satisfied: <ul style="list-style-type: none"> • Engine speed: More than 600 rpm • Primary pulley speed: More than 450 rpm • Idle is not being detected. • Acceleration/deceleration speed: -0.49 m/s^2 (-0.05 G) or more • The primary pulley speed experienced 300 rpm or more and the secondary pulley speed experienced 250 rpm or more at least once. • Secondary pulley speed: More than 150 rpm • TCM power supply voltage: More than 11 V
			Signal	—
			Threshold	The following condition is detected twice or more (1 second or more later after detection of the first) in the same DC <ul style="list-style-type: none"> • Status with the shifting ratio of the primary pulley speed/secondary pulley ratio exceeding 2.825 is 0.2 sec or more continuously
			Diagnosis delay time	—
		2	Diagnosis condition	When all of the following conditions are satisfied: <ul style="list-style-type: none"> • Engine speed: More than 600 rpm • Primary pulley speed: More than 450 rpm • Idle is not being detected. • Acceleration/deceleration speed: -0.49 m/s^2 (-0.05 G) or more • The primary pulley speed experienced 300 rpm or more and the secondary pulley speed experienced 250 rpm or more at least once. • Secondary pulley speed: More than 150 rpm • TCM power supply voltage: More than 11 V
			Signal	—
			Threshold	The following condition is detected twice or more (1 second or more later after detection of the first) in the same DC <ul style="list-style-type: none"> • Status with the shifting ratio of the primary pulley speed/secondary pulley ratio exceeding 3.625 is 0.1 sec or more continuously.
			Diagnosis delay time	—

NOTE:

DC stands for "DRIVING CYCLE" and indicates a series of driving cycle of "Ignition switch OFF → ON → driving → OFF".

POSSIBLE CAUSE

- Line pressure solenoid valve
- Control valve assembly

FAIL-SAFE

- Selector shock is large
- Start is slow
- Acceleration is slow
- Lock-up is not performed

DTC CONFIRMATION PROCEDURE

P0746 PRESSURE CONTROL SOLENOID A

< DTC/CIRCUIT DIAGNOSIS >

[CVT: RE0F10H]

CAUTION:

Be careful of the driving speed.

1. PREPARATION BEFORE WORK

If another "DTC CONFIRMATION PROCEDURE" occurs just before, turn ignition switch OFF and wait for at least 10 seconds, then perform the next test.

>> GO TO 2.

2. CHECK DTC DETECTION

1. Start the engine.
2. Drive the vehicle.
3. Maintain the following conditions for 10 seconds or more.

Selector lever	: "D" position
Accelerator pedal position	: 0.5/8 or more
Vehicle speed	: 40 km/h (25 MPH) or more

4. Stop the vehicle.
5. Check the first trip DTC.

Is "P0746" detected?

- YES >> Go to [TM-128, "Diagnosis Procedure"](#).
NO-1 >> To check malfunction symptom before repair: Refer to [GI-41, "Intermittent Incident"](#).
NO-2 >> Confirmation after repair: INSPECTION END

Diagnosis Procedure

INFOID:0000000012436480

1. CHECK INTERMITTENT INCIDENT

Refer to [GI-41, "Intermittent Incident"](#).

Is the inspection result normal?

- YES >> Replace transaxle assembly. Refer to [TM-212, "Removal and Installation"](#).
NO >> Repair or replace the malfunction items.

P0776 PRESSURE CONTROL SOLENOID B

< DTC/CIRCUIT DIAGNOSIS >

[CVT: RE0F10H]

P0776 PRESSURE CONTROL SOLENOID B

DTC Description

INFOID:000000012436481

DTC DETECTION LOGIC

DTC	CONSULT screen terms (Trouble diagnosis content)	DTC detection condition		
P0776	PC SOLENOID B (Pressure Control Solenoid "B" Performance/Stuck Off)	1	Diagnosis condition	When all of the following conditions are satisfied: <ul style="list-style-type: none"> • DTC other than the applicable DTC is not detected. • Engine speed: More than 625 rpm • Selector lever: Other than P/N position • CVT fluid temperature: More than -20°C (-4°F) • TCM power supply: More than 11 V • The difference between instruction pressure of secondary pressure and 10-msec-ago instruction secondary pressure is 0 MPa or more • Instruction pressure of secondary pressure: 0 MPa or more • Instruction pressure of secondary pressure - secondary pressure: More than 1.2 MPa
			Signal	—
			Threshold	When all of the following conditions are satisfied and this state is maintained for 1.52 seconds: <ul style="list-style-type: none"> • DTC other than the applicable DTC is not detected. • CVT fluid temperature: More than -20°C (-4°F) • Selector lever: Other than P/N position • Instruction pressure of secondary pressure - secondary pressure: 0.25 MPa or more
			Diagnosis delay time	Maintained for 10 seconds or more
		2	Diagnosis condition	When all of the following conditions are satisfied: <ul style="list-style-type: none"> • DTC other than the applicable DTC is not detected. • CVT fluid temperature: More than -20°C (-4°F) • Selector lever: Other than P/N position • TCM power supply: More than 11 V • The difference between instruction pressure of secondary pressure and 10-msec-ago instruction secondary pressure is 0 MPa or more • Secondary pressure - instruction pressure of secondary pressure: More than 1.2 MPa
			Signal	—
			Threshold	When all of the following conditions are satisfied and this state is maintained for 5.5 seconds: <ul style="list-style-type: none"> • DTC other than the applicable DTC is not detected. • CVT fluid temperature: More than -20°C (-4°F) • Selector lever: Other than P/N position • Secondary pressure - instruction pressure of secondary pressure: 1.2 MPa or more
			Diagnosis delay time	Maintained for 10 seconds or more

POSSIBLE CAUSE

Secondary pressure solenoid valve

FAIL-SAFE

- When a malfunction occurs on the low oil pressure side
 - Selector shock is large
 - Start is slow
 - Acceleration is slow
 - Lock-up is not performed
 - Vehicle speed is not increased
- When a malfunction occurs on the high oil pressure side

P0776 PRESSURE CONTROL SOLENOID B

< DTC/CIRCUIT DIAGNOSIS >

[CVT: RE0F10H]

- Selector shock is large
- Start is slow
- Acceleration is slow
- Lock-up is not performed

DTC CONFIRMATION PROCEDURE

CAUTION:

Always drive vehicle at a safe speed.

1. PREPARATION BEFORE WORK

If another "DTC CONFIRMATION PROCEDURE" occurs just before, turn ignition switch OFF and wait for at least 10 seconds, then perform the next test.

>> GO TO 2.

2. CHECK DTC DETECTION

1. Start the engine.
2. Drive the vehicle.
3. Maintain the following condition for 20 seconds or more.

Selector lever	: "D" position
Vehicle speed	: 40 km/h (25 MPH) or more
Accelerator pedal position	: 1.0/8 or more

4. Stop the vehicle.
5. Check the first trip DTC.

Is "P0776" detected?

YES >> Go to [TM-130, "Diagnosis Procedure"](#).

NO-1 >> To check malfunction symptom before repair: Refer to [GI-41, "Intermittent Incident"](#).

NO-2 >> Confirmation after repair: INSPECTION END

Diagnosis Procedure

INFOID:000000012436482

1. CHECK INTERMITTENT INCIDENT

Refer to [GI-41, "Intermittent Incident"](#).

Is the inspection result normal?

YES >> Replace transaxle assembly. Refer to [TM-212, "Removal and Installation"](#).

NO >> Repair or replace the malfunction items.

P0778 PRESSURE CONTROL SOLENOID B

< DTC/CIRCUIT DIAGNOSIS >

[CVT: RE0F10H]

P0778 PRESSURE CONTROL SOLENOID B

DTC Description

INFOID:000000012436483

DTC DETECTION LOGIC

DTC	CONSULT screen terms (Trouble diagnosis content)	DTC detection condition	
		Diagnosis condition	TCM power supply voltage: More than 11 V
P0778	PC SOLENOID B (Pressure Control Solenoid "B" Electrical)	Signal	—
		Threshold	TCM judges that solenoid valve circuit is shorted to ground
		Diagnosis delay time	Maintained for 1 second

POSSIBLE CAUSE

- Harness or connector (Secondary pressure solenoid valve circuit is shorted to ground)
- Secondary pressure solenoid valve

FAIL-SAFE

- Selector shock is large
- Start is slow
- Acceleration is slow
- Lock-up is not performed

DTC CONFIRMATION PROCEDURE

CAUTION:

Always drive vehicle at a safe speed.

1. PREPARATION BEFORE WORK

If another "DTC CONFIRMATION PROCEDURE" occurs just before, turn ignition switch OFF and wait for at least 10 seconds, then perform the next test.

>> GO TO 2.

2. CHECK DTC DETECTION

1. Start the engine and wait for 5 seconds or more.
2. Check the first trip DTC.

Is "P0778" detected?

YES >> Go to [TM-131, "Diagnosis Procedure"](#).

NO-1 >> To check malfunction symptom before repair: Refer to [GI-41, "Intermittent Incident"](#).

NO-2 >> Confirmation after repair: INSPECTION END

Diagnosis Procedure

INFOID:000000012436484

1. CHECK CIRCUIT BETWEEN TCM AND CVT UNIT

1. Turn ignition switch OFF.
2. Disconnect TCM connector and CVT unit connector.
3. Check continuity between TCM harness connector terminal and ground.

TCM		—	Continuity
Connector	Terminal		
F89	39	Ground	Not existed

Is the inspection result normal?

YES >> GO TO 2.

NO >> Repair or replace damaged parts.

2. CHECK SECONDARY PRESSURE SOLENOID VALVE CIRCUIT

P0778 PRESSURE CONTROL SOLENOID B

< DTC/CIRCUIT DIAGNOSIS >

[CVT: RE0F10H]

Check resistance between CVT unit harness connector terminal and ground.

CVT unit		—	Condition	Resistance
Connector	Terminal			
F209	3	Ground	CVT fluid temperature: 20°C (68°F)	5.5 – 7.0 Ω
			CVT fluid temperature: 50°C (122°F)	6.0 – 8.0 Ω
			CVT fluid temperature: 80°C (176°F)	6.5 – 8.5 Ω

Is the inspection result normal?

- YES >> Check intermittent incident. Refer to [GI-41, "Intermittent Incident"](#).
- NO >> There is malfunction of secondary pressure solenoid valve circuit. Replace transaxle assembly.
Refer to [TM-212, "Removal and Installation"](#).

P0779 PRESSURE CONTROL SOLENOID B

< DTC/CIRCUIT DIAGNOSIS >

[CVT: RE0F10H]

P0779 PRESSURE CONTROL SOLENOID B

DTC Description

INFOID:000000012436485

DTC DETECTION LOGIC

DTC	CONSULT screen terms (Trouble diagnosis content)	DTC detection condition	
P0779	PC SOLENOID B (Pressure control solenoid B Intermittent)	Diagnosis condition	When all of the following conditions are satisfied: • TCM power supply voltage: More than 11 V • P0778 is not detected
		Signal	—
		Threshold	TCM judges that solenoid valve circuit is open or shorted to power supply
		Diagnosis delay time	Maintained for 1 second

POSSIBLE CAUSE

- Harness or connector (Secondary pressure solenoid valve circuit open or shorted to power supply)
- Secondary pressure solenoid valve

FAIL-SAFE

- Selector shock is large
- Start is slow
- Acceleration is slow
- Lock-up is not performed

DTC CONFIRMATION PROCEDURE

1. PREPARATION BEFORE WORK

If another "DTC CONFIRMATION PROCEDURE" occurs just before, turn ignition switch OFF and wait for at least 10 seconds, then perform the next test.

>> GO TO 2.

2. CHECK DTC DETECTION

1. Start the engine.
2. Drive the vehicle.
3. Maintain the following conditions for 5 seconds or more.

Selector lever : "D" position

Vehicle speed : 40 km/h (25 MPH) or more

4. Stop the vehicle.
5. Check the first trip DTC.

Is "P0779" detected?

YES >> Go to [TM-133, "Diagnosis Procedure"](#).

NO-1 >> To check malfunction symptom before repair: Refer to [GI-41, "Intermittent Incident"](#).

NO-2 >> Confirmation after repair: INSPECTION END

Diagnosis Procedure

INFOID:000000012436486

1. CHECK CIRCUIT BETWEEN TCM AND CVT UNIT

1. Turn ignition switch OFF.
2. Disconnect TCM connector and CVT unit connector.
3. Check continuity between TCM harness connector terminal and CVT unit harness connector terminal.

P0779 PRESSURE CONTROL SOLENOID B

< DTC/CIRCUIT DIAGNOSIS >

[CVT: RE0F10H]

TCM		CVT unit		Continuity
Connector	Terminal	Connector	Terminal	
F89	39	F43	3	Existed

Is the inspection result normal?

YES >> GO TO 2.

NO >> Repair or replace damaged parts.

2.CHECK SECONDARY PRESSURE SOLENOID VALVE CIRCUIT

Check resistance between CVT unit harness connector terminal and ground.

CVT unit		—	Condition	Resistance
Connector	Terminal			
F209	3	Ground	CVT fluid temperature: 20°C (68°F)	5.5 – 7.0 Ω
			CVT fluid temperature: 50°C (122°F)	6.0 – 8.0 Ω
			CVT fluid temperature: 80°C (176°F)	6.5 – 8.5 Ω

Is the inspection result normal?

YES >> Check intermittent incident. Refer to [GI-41, "Intermittent Incident"](#).

NO >> There is malfunction of secondary pressure solenoid valve circuit. Replace transaxle assembly.
Refer to [TM-212, "Removal and Installation"](#).

P0826 UP AND DOWN SHIFT SW

< DTC/CIRCUIT DIAGNOSIS >

[CVT: RE0F10H]

P0826 UP AND DOWN SHIFT SW

DTC Description

INFOID:000000012436487

DTC DETECTION LOGIC

DTC	CONSULT screen terms (Trouble diagnosis content)	DTC detection condition	
P0826	UP/DOWN SHIFT SWITCH (Up and Down Shift Switch Circuit)	Diagnosis condition	Engine is started
		Signal	—
		Threshold	TCM monitors manual mode, non-manual mode, up or down switch signal, and detects as irregular when impossible input pattern occurs
		Diagnosis delay time	1 second or more

POSSIBLE CAUSE

- Manual mode switch
- Paddle shifter
- Harness or connectors
(Manual mode switch circuit are open or shorted.)
- Harness or connectors
(Paddle shifter circuit are open or shorted.)

FAIL-SAFE

Manual mode is not activated

DTC CONFIRMATION PROCEDURE

1. PREPARATION BEFORE WORK

If another "DTC CONFIRMATION PROCEDURE" occurs just before, turn ignition switch OFF and wait for at least 10 seconds, then perform the next test.

>> GO TO 2.

2. CHECK DTC DETECTION (PART 1)

Ⓜ With CONSULT

1. Start the engine.
2. Shift the selector lever to "D" position and wait for 1 second or more.
3. Select "Self Diagnostic Results" in "TRANSMISSION".

Is "P0826" detected?

- YES >> Go to [TM-136, "Diagnosis Procedure"](#).
NO >> GO TO 3.

3. CHECK DTC DETECTION (PART 2)

Ⓜ With CONSULT

1. Shift the selector lever to manual shift gate and wait for 1 second or more.
2. Select "Self Diagnostic Results" in "TRANSMISSION".

Is "P0826" detected?

- YES >> Go to [TM-136, "Diagnosis Procedure"](#).
NO >> GO TO 4.

4. CHECK DTC DETECTION (PART 3)

Ⓜ With CONSULT

1. Shift the selector lever to "UP side (+ side)" and wait for 1 second or more.
2. Select "Self Diagnostic Results" in "TRANSMISSION".

Is "P0826" detected?

- YES >> Go to [TM-136, "Diagnosis Procedure"](#).

P0826 UP AND DOWN SHIFT SW

< DTC/CIRCUIT DIAGNOSIS >

[CVT: RE0F10H]

NO >> GO TO 5.

5.CHECK DTC DETECTION (PART 4)

Ⓟ With CONSULT

- Shift the selector lever to "DOWN side (- side)" and wait for 1 second or more.
- Select "Self Diagnostic Results" in "TRANSMISSION".

Is "P0826" detected?

- YES >> Go to [TM-136, "Diagnosis Procedure"](#).
- NO-1 >> To check malfunction symptom before repair: Refer to [GI-41, "Intermittent Incident"](#).
- NO-2 >> Confirmation after repair: INSPECTION END

Diagnosis Procedure

INFOID:000000012436488

1.CHECK DTC (COMBINATION METER)

Ⓟ With CONSULT

- Turn ignition switch ON.
- Select "Self Diagnostic Results" in "METER/M&A".

Is any DTC detected?

- YES >> Check DTC detected item. Refer to [MWI-29, "DTC Index"](#).
- NO >> GO TO 2.

2.CHECK MANUAL MODE SWITCH SIGNALS

Ⓟ With CONSULT

- Turn ignition switch ON.
- Select "Data Monitor" in "TRANSMISSION".
- Check the On/Off operations of each monitor item.

Item name	Monitor item	Condition	Status
Manual mode switch	MMODE	Manual shift gate position	On
		Other than the above	Off
	NONMMODE	Manual shift gate position	Off
		Other than the above	On
	UPLVR	Selector lever: UP (+ side)	On
		Other than the above	Off
DOWNLVR	Selector lever: DOWN (- side)	On	
	Other than the above	Off	
Paddle shifter*	STRDWNSW	Pressed paddle shifter (shift-down)	On
		Released paddle shifter	Off
	STRUPSW	Pressed paddle shifter (shift-up)	On
		Released paddle shifter	Off

*: With paddle shifter

ⓧ Without CONSULT

Drive vehicle in the manual mode, and confirm that the actual gear position and the meter's indication of the position mutually coincide when the selector lever and paddle shifter* are shifted to the "+" (up)" or "-" (down)" side [1st ⇔ 7th gear].

Is the inspection result normal?

- YES >> Check intermittent incident. Refer to [GI-41, "Intermittent Incident"](#).
- NO-1 (Manual mode switch is abnormal)>>GO TO 3.
- NO-2 (Paddle shifter is abnormal)>>GO TO 8.

3.CHECK MANUAL MODE SWITCH POWER SUPPLY CIRCUIT

- Turn ignition switch OFF.
- Disconnect CVT shift selector connector.
- Turn ignition switch ON.

P0826 UP AND DOWN SHIFT SW

< DTC/CIRCUIT DIAGNOSIS >

[CVT: RE0F10H]

4. Check voltage between CVT shift selector harness connector terminal and ground.

+		-	Condition	Voltage (Approx.)
CVT shift selector				
Connector	Terminal			
M78	7	Ground	Ignition switch: ON	12 V
			Ignition switch: OFF	0 V
	8		Ignition switch: ON	12 V
			Ignition switch: OFF	0 V
	9		Ignition switch: ON	12 V
			Ignition switch: OFF	0 V
	10		Ignition switch: ON	12 V
			Ignition switch: OFF	0 V

Is the inspection result normal?

- YES >> GO TO 4.
- NO >> GO TO 5.

4. CHECK MANUAL MODE SWITCH

1. Turn ignition switch OFF.
2. Check manual mode switch. Refer to [TM-139, "Component Inspection \(Manual Mode Switch\)"](#).

Is the inspection result normal?

- YES >> GO TO 7.
- NO >> Repair or replace damaged parts.

5. CHECK CIRCUIT BETWEEN CVT SHIFT SELECTOR AND COMBINATION METER (PART 1)

1. Turn ignition switch OFF.
2. Disconnect combination meter connector.
3. Check continuity between CVT shift selector harness connector terminals and combination meter harness connector terminals.

CVT shift selector		Combination meter		Continuity
Connector	Terminal	Connector	Terminal	
M78	7	M24	30	Existed
	8		33	
	9		32	
	10		31	

Is the inspection result normal?

- YES >> GO TO 6.
- NO >> Repair or replace damaged parts.

6. CHECK CIRCUIT BETWEEN CVT SHIFT SELECTOR AND COMBINATION METER (PART 2)

Check continuity between CVT shift selector harness connector terminals and ground.

CVT shift selector		—	Continuity
Connector	Terminal		
M78	7	Ground	Not existed
	8		
	9		
	10		

Is the inspection result normal?

P0826 UP AND DOWN SHIFT SW

[CVT: RE0F10H]

< DTC/CIRCUIT DIAGNOSIS >

- YES >> Check intermittent incident. Refer to [GI-41, "Intermittent Incident"](#).
NO >> Repair or replace damaged parts.

7.CHECK GROUND CIRCUIT

Check continuity between CVT shift selector harness connector terminal and ground.

CVT shift selector		—	Continuity
Connector	Terminal		
M78	11	Ground	Existed

Is the inspection result normal?

- YES >> Check intermittent incident. Refer to [GI-41, "Intermittent Incident"](#).
NO >> Repair or replace damaged parts.

8.CHECK PADDLE SHIFTER

1. Turn ignition switch OFF.
2. Disconnect paddle shifter connector.
3. Turn ignition switch ON.
4. Check voltage between paddle shifter side harness connector terminals.

Paddle shifter			Voltage (Approx.)
Connector	Terminal		
M82	3	1	12 V
M83	3	1	

Is the inspection result normal?

- YES >> GO TO 9.
NO >> GO TO 11.

9.CHECK PADDLE SHIFTER

Check paddle shifter. Refer to [TM-140, "Component Inspection \(Paddle Shifter\)"](#).

Is the inspection result normal?

- YES >> GO TO 10.
NO >> Repair or replace damaged parts.

10.CHECK GROUND CIRCUIT

Check continuity between paddle shifter vehicle side harness connector terminal and ground.

Paddle shifter		Ground	Continuity
Connector	Terminal		
M82	1		Existed
M83	1		

Is the inspection result normal?

- YES >> GO TO 11.
NO >> Repair or replace damaged parts.

11.CHECK POWER SOURCE CIRCUIT

Check voltage between paddle shifter vehicle side harness connector terminal and ground.

Paddle shifter		Ground	Voltage (Approx.)
Connector	Terminal		
M82	3		0 V
M83	3		

Is the inspection result normal?

P0826 UP AND DOWN SHIFT SW

< DTC/CIRCUIT DIAGNOSIS >

[CVT: RE0F10H]

- YES >> GO TO 12.
 NO >> Repair or replace damaged parts.

12.CHECK HARNESS BETWEEN PADDLE SHIFTER AND COMBINATION METER (PART 1)

1. Disconnect combination meter connector.
2. Check continuity between paddle shifter vehicle side harness connector terminals and combination meter vehicle side harness connector terminals.

Paddle shifter		Combination meter		Continuity
Connector	Terminal	Connector	Terminal	
M82	3	M24	34	Existed
M83	3		35	

Is the inspection result normal?

- YES >> GO TO 13.
 NO >> Repair or replace damaged parts.

13.CHECK HARNESS BETWEEN PADDLE SHIFTER AND COMBINATION METER (PART 2)

Check continuity between paddle shifter vehicle side harness connector terminals and ground.

Paddle shifter		Ground	Continuity
Connector	Terminal		
M82	3		Not existed
M83	3		

Is the inspection result normal?

- YES >> GO TO 14.
 NO >> Repair or replace damaged parts.

14.DETECT MALFUNCTIONING ITEMS

Check TCM connector pin terminals for damage or loose connection with harness connector.

Is the inspection result normal?

- YES >> Replace TCM. Refer to [TM-191, "Removal and Installation"](#).
 NO >> Repair or replace damaged parts.

Component Inspection (Manual Mode Switch)

INFOID:0000000012436489

1.MANUAL MODE SWITCH

Check continuity between CVT shift selector connector terminals.

CVT shift selector	Condition	Continuity
Terminal		
7 – 11	Manual shift gate position (neutral)	Existed
	Other than the above	Not existed
8 – 11	Selector lever: DOWN (– side)	Existed
	Other than the above	Not existed
9 – 11	Selector lever: UP (+ side)	Existed
	Other than the above	Not existed
10 – 11	Manual shift gate position	Not existed
	Other than the above	Existed

Is the inspection result normal?

- YES >> INSPECTION END
 NO >> Replace the CVT shift selector assembly due to malfunction in manual mode switch. Refer to [TM-185, "Removal and Installation"](#).

P0826 UP AND DOWN SHIFT SW

< DTC/CIRCUIT DIAGNOSIS >

[CVT: RE0F10H]

Component Inspection (Paddle Shifter)

INFOID:000000012512324

1. CHECK PADDLE SHIFTER

Check continuity between paddle shifter connector terminals.

Paddle shifter		Condition	Continuity
Terminal			
1	3	Pressed paddle shifter (shift-up)	Existed
		Released paddle shifter	Not existed
1	3	Pressed paddle shifter (shift-down)	Existed
		Released paddle shifter	Not existed

Is the inspection result normal?

YES >> INSPECTION END

NO >> Repair or replace damaged parts.

P0841 TRANSMISSION FLUID PRESSURE SEN/SW A

< DTC/CIRCUIT DIAGNOSIS >

[CVT: RE0F10H]

P0841 TRANSMISSION FLUID PRESSURE SEN/SW A

DTC Description

INFOID:000000012436490

DTC DETECTION LOGIC

DTC	CONSULT screen terms (Trouble diagnosis content)	DTC detection condition	
P0841	FLUID PRESS SEN/SW A (Transmission Fluid Pressure Sensor/ Switch "A" Circuit Range/Performance)	Diagnosis condition	When all of the following conditions are satisfied: <ul style="list-style-type: none"> • TCM power supply voltage: More than 11 V • DTC other than the applicable DTC is not detected. • Primary pulley speed: 300 rpm or more • Secondary pulley speed: 250 rpm or more • Target speed for shifting: Less than 0.1 seconds • Pulley ratio: 0.5 – 1.0
		Signal	—
		Threshold	Primary pulley pressure is outside the specified value
		Diagnosis delay time	Maintained for 5 seconds

POSSIBLE CAUSE

- Harness or connector (Secondary pressure sensor circuit is open or shorted)
- Harness or connector (Primary pressure sensor circuit is open or shorted)
- Secondary pressure sensor

FAIL-SAFE

Not changed from normal driving

DTC CONFIRMATION PROCEDURE

CAUTION:

Always drive vehicle at a safe speed.

1. PREPARATION BEFORE WORK

If another "DTC CONFIRMATION PROCEDURE" occurs just before, turn ignition switch OFF and wait for at least 10 seconds, then perform the next test.

>> GO TO 2.

2. CHECK DTC DETECTION

1. Start the engine.
2. Drive the vehicle.
3. Maintain the following condition for 10 seconds or more.

Selector lever : "D" position

Vehicle speed : Constant speed of 40 km/h (25 MPH)

CAUTION:

Also keep the accelerator pedal position constant.

4. Stop the vehicle.
5. Check the first trip DTC.

Is "P0841" detected?

YES >> Go to [TM-142. "Diagnosis Procedure"](#).

NO-1 >> To check malfunction symptom before repair: Refer to [GI-41. "Intermittent Incident"](#).

NO-2 >> Confirmation after repair: INSPECTION END

P0841 TRANSMISSION FLUID PRESSURE SEN/SW A

< DTC/CIRCUIT DIAGNOSIS >

[CVT: RE0F10H]

Diagnosis Procedure

INFOID:000000012436491

1. CHECK INTERMITTENT INCIDENT

Refer to [GI-41, "Intermittent Incident"](#).

Is the inspection result normal?

- YES >> Replace the transaxle assembly. Refer to [TM-212, "Removal and Installation"](#).
- NO >> Repair or replace damaged parts.

P0847 TRANSMISSION FLUID PRESSURE SEN/SW B

< DTC/CIRCUIT DIAGNOSIS >

[CVT: RE0F10H]

P0847 TRANSMISSION FLUID PRESSURE SEN/SW B

DTC Description

INFOID:000000012436492

DTC DETECTION LOGIC

DTC	CONSULT screen terms (Trouble diagnosis content)	DTC detection condition	
P0847	FLUID PRESS SEN/SW B (Transmission Fluid Pressure Sensor/ Switch B Circuit Low)	Diagnosis condition	When all of the following conditions are satisfied: <ul style="list-style-type: none">• CVT fluid temperature: More than -20°C (-4°F)• TCM power supply voltage: 11 V or more
		Signal	—
		Threshold	Secondary pressure sensor voltage: 0.09 V or less
		Diagnosis delay time	Maintained for 5 seconds

POSSIBLE CAUSE

- Harness or connector (Secondary pressure sensor circuit is open or shorted to ground)
- Secondary pressure sensor
- Control valve assembly

FAIL-SAFE

Not changed from normal driving

DTC CONFIRMATION PROCEDURE

1. PREPARATION BEFORE WORK

If another "DTC CONFIRMATION PROCEDURE" occurs just before, turn ignition switch OFF and wait for at least 10 seconds, then perform the next test.

>> GO TO 2.

2. CHECK DTC DETECTION

With CONSULT

1. Start the engine.
2. Select "Data Monitor" in "TRANSMISSION".
3. Select "FLUID TEMP".
4. Maintain the following conditions for 10 seconds or more.

FLUID TEMP : -20°C (-4°F)

5. Check the first trip DTC.

With GST

1. Start the engine and wait for at least 10 seconds.

CAUTION:

When the ambient temperature is less than -20°C (-4°F) and the engine is cold, warm up the engine for approximately 5 minutes.

2. Check the first trip DTC.

Is "P0847" detected?

YES >> Go to [TM-143, "Diagnosis Procedure"](#).

NO-1 >> To check malfunction symptom before repair: Refer to [GI-41, "Intermittent Incident"](#).

NO-2 >> Confirmation after repair: INSPECTION END

Diagnosis Procedure

INFOID:000000012436493

1. CHECK TCM INPUT SIGNALS

1. Turn ignition switch OFF.

P0847 TRANSMISSION FLUID PRESSURE SEN/SW B

< DTC/CIRCUIT DIAGNOSIS >

[CVT: RE0F10H]

2. Start the engine.
3. Check voltage between TCM harness connector terminals.

+		-	Condition	Voltage
TCM				
Connector	Terminal			
F89	16	Ground	<ul style="list-style-type: none">• Selector lever: "N" position• At idle	1.2 – 1.3 V

Is the inspection result normal?

YES >> Check intermittent incident. Refer to [GI-41. "Intermittent Incident"](#).

NO >> GO TO 2.

2. CHECK CIRCUIT BETWEEN TCM AND CVT UNIT (PART 1)

1. Turn ignition switch OFF.
2. Disconnect TCM connector and CVT unit connector.
3. Check continuity between TCM harness connector terminals and CVT unit harness connector terminals.

TCM		CVT unit		Continuity
Connector	Terminal	Connector	Terminal	
F89	11	F43	18	Existed
	16		14	
	26		22	

Is the inspection result normal?

YES >> GO TO 3.

NO >> Repair or replace malfunctioning parts.

3. CHECK CIRCUIT BETWEEN TCM AND CVT UNIT (PART 2)

Check continuity between TCM harness connector terminals and ground.

TCM		—	Continuity
Connector	Terminal		
F89	16	Ground	Not existed
	26		

Is the inspection result normal?

YES >> There is malfunction of secondary pressure sensor circuit. Replace transaxle assembly. Refer to [TM-212. "Removal and Installation"](#).

NO >> Repair or replace malfunctioning parts.

P0848 TRANSMISSION FLUID PRESSURE SEN/SW B

< DTC/CIRCUIT DIAGNOSIS >

[CVT: RE0F10H]

P0848 TRANSMISSION FLUID PRESSURE SEN/SW B

DTC Description

INFOID:000000012436494

DTC DETECTION LOGIC

DTC	CONSULT screen terms (Trouble diagnosis content)	DTC detection condition	
P0848	FLUID PRESS SEN/SW B (Transmission Fluid Pressure Sensor/ Switch B Circuit Low)	Diagnosis condition	When all of the following conditions are satisfied: <ul style="list-style-type: none"> • CVT fluid temperature: More than -20°C (-4°F) • TCM power supply voltage: More than 11 V • Instruction secondary pressure: 5.7 MPa or less
		Signal	—
		Threshold	Secondary pressure sensor voltage: 4.7 V or more
		Diagnosis delay time	Maintained for 5 seconds

POSSIBLE CAUSE

- Harness or connector (Secondary pressure sensor circuit is shorted to power supply)
- Secondary pressure sensor
- Control valve assembly

FAIL-SAFE

Not changed from normal driving

DTC CONFIRMATION PROCEDURE

1. PREPARATION BEFORE WORK

If another "DTC CONFIRMATION PROCEDURE" occurs just before, the ignition switch OFF and wait for at least 10 seconds, then perform the next test.

>> GO TO 2.

2. CHECK DTC DETECTION

With CONSULT

1. Start the engine.
2. Select "Data Monitor" in "TRANSMISSION".
3. Select "FLUID TEMP".
4. Maintain the following conditions for 10 seconds or more.

FLUID TEMP : More than -20°C (-4°F)

5. Check the first trip DTC.

With GST

1. Start the engine and wait for at least 10 seconds.

CAUTION:

When the ambient temperature is less than -20°C (-4°F) and the engine is cold, warm up the engine for approximately 5 minutes.

2. Check the first trip DTC.

Is "P0848" detected?

YES >> Go to [TM-146, "Diagnosis Procedure"](#).

NO-1 >> To check malfunction symptom before repair: Refer to [GI-41, "Intermittent Incident"](#).

NO-2 >> Confirmation after repair: INSPECTION END

P0848 TRANSMISSION FLUID PRESSURE SEN/SW B

< DTC/CIRCUIT DIAGNOSIS >

[CVT: RE0F10H]

INFOID:000000012436495

Diagnosis Procedure

1. CHECK TCM INPUT SIGNALS

1. Turn ignition switch OFF.
2. Start the engine.
3. Check voltage between TCM harness connector terminals.

+		-	Condition	Voltage
TCM				
Connector	Terminal			
F89	16	Ground	<ul style="list-style-type: none">• Selector lever: "N" position• At idle	1.2 – 1.3 V

Is the inspection result normal?

YES >> Check intermittent incident. Refer to [GI-41, "Intermittent Incident"](#).

NO >> GO TO 2.

2. CHECK SECONDARY PRESSURE SENSOR POWER CIRCUIT

1. Turn ignition switch OFF.
2. Connect TCM connector.
3. Disconnect CVT unit connector.
4. Turn ignition switch ON.
5. Check voltage between CVT unit harness connector terminal and ground.

+		-	Voltage (Approx.)
CVT unit			
Connector	Terminal		
F43	22	Ground	5.0 V

Is the inspection result normal?

YES >> GO TO 3.

NO >> Repair or replace malfunctioning parts.

3. CHECK SECONDARY PRESSURE SENSOR SIGNAL CIRCUIT

Check voltage between CVT unit harness connector terminal and ground.

+		-	Voltage (Approx.)
CVT unit			
Connector	Terminal		
F43	14	Ground	0 V

Is the inspection result normal?

YES >> There is malfunction of secondary pressure sensor circuit. Replace transaxle assembly. Refer to [TM-212, "Removal and Installation"](#).

NO >> Repair or replace malfunctioning parts.

P084C TRANSMISSION FLUID PRESSURE SEN/SW H

< DTC/CIRCUIT DIAGNOSIS >

[CVT: RE0F10H]

P084C TRANSMISSION FLUID PRESSURE SEN/SW H

DTC Description

INFOID:000000012436496

DTC DETECTION LOGIC

DTC	CONSULT screen terms (Trouble diagnosis content)	DTC detection condition	
P084C	FLUID PRESS SEN/SW H (Transmission Fluid Pressure Sensor/ Switch H Circuit Low)	Diagnosis condition	When all of the following conditions are satisfied: • CVT fluid temperature: More than -20°C (-4°F) • TCM power supply voltage: More than 11 V
		Signal	—
		Threshold	Primary pressure sensor voltage: 0.09 V or less
		Diagnosis delay time	Maintained for 5 seconds

POSSIBLE CAUSE

- Harness or connector (Primary pressure sensor circuit is open or shorted to ground)
- Primary pressure sensor
- Control valve assembly

FAIL-SAFE

Not changed from normal driving

DTC CONFIRMATION PROCEDURE

1. PREPARATION BEFORE WORK

If another "DTC CONFIRMATION PROCEDURE" occurs just before, turn ignition switch OFF and wait for at least 10 seconds, then perform the next test.

>> GO TO 2.

2. CHECK DTC DETECTION

Ⓜ With CONSULT

1. Start the engine.
2. Select "Data Monitor" in "TRANSMISSION".
3. Select "FLUID TEMP".
4. Maintain the following conditions for 10 seconds or more.

FLUID TEMP : More than -20°C (-4°F)

5. Check the first trip DTC.

Ⓜ With GST

1. Start the engine and wait for at least 10 seconds.

CAUTION:

When the ambient temperature is less than -20°C (-4°F) and the engine is cold, warm up the engine for approximately 5 minutes.

2. Check the first trip DTC.

Is "P084C" detected?

YES >> Go to [TM-146, "Diagnosis Procedure"](#).

NO-1 >> To check malfunction symptom before repair: Refer to [GI-41, "Intermittent Incident"](#).

NO-2 >> Confirmation after repair: INSPECTION END

Diagnosis Procedure

INFOID:000000012436497

1. CHECK TCM INPUT SIGNALS

1. Turn ignition switch OFF.

P084C TRANSMISSION FLUID PRESSURE SEN/SW H

< DTC/CIRCUIT DIAGNOSIS >

[CVT: RE0F10H]

2. Start the engine.
3. Check voltage between TCM harness connector terminals.

+		-	Condition	Voltage
TCM				
Connector	Terminal			
F89	17	Ground	<ul style="list-style-type: none"> • Selector lever: "N" position • At idle 	0.9 V

Is the inspection result normal?

YES >> Check intermittent incident. Refer to [GI-41. "Intermittent Incident"](#).

NO >> GO TO 2.

2. CHECK CIRCUIT BETWEEN TCM AND CVT UNIT (PART 1)

1. Turn ignition switch OFF.
2. Disconnect TCM connector and CVT unit connector.
3. Check continuity between TCM harness connector terminals and CVT unit harness connector terminals.

TCM		CVT unit		Continuity
Connector	Terminal	Connector	Terminal	
F89	11	F43	18	Existed
	17		13	
	26		22	

Is the inspection result normal?

YES >> GO TO 3.

NO >> Repair or replace malfunctioning parts.

3. CHECK CIRCUIT BETWEEN TCM AND CVT UNIT (PART 2)

Check continuity between TCM harness connector terminals and ground.

TCM		—	Continuity
Connector	Terminal		
F89	17	Ground	Not existed
	26		

Is the inspection result normal?

YES >> There is malfunction of primary pressure sensor circuit. Replace transaxle assembly. Refer to [TM-212. "Removal and Installation"](#).

NO >> Repair or replace malfunctioning parts.

P084D TRANSMISSION FLUID PRESSURE SEN/SW H

< DTC/CIRCUIT DIAGNOSIS >

[CVT: RE0F10H]

P084D TRANSMISSION FLUID PRESSURE SEN/SW H

DTC Description

INFOID:000000012436498

DTC DETECTION LOGIC

DTC	CONSULT screen terms (Trouble diagnosis content)	DTC detection condition	
P084D	FLUID PRESS SEN/SW H (Transmission Fluid Pressure Sensor/ Switch "H" Circuit High)	Diagnosis condition	When all of the following conditions are satisfied: • CVT fluid temperature: More than -20°C (-4°F) • TCM power supply voltage: More than 11 V
		Signal	—
		Threshold	Primary pressure sensor voltage: 4.7 V or more
		Diagnosis delay time	Maintained for 5 seconds

POSSIBLE CAUSE

- Harness or connector (Primary pressure sensor circuit is open or shorted to ground)
- Primary pressure sensor
- Control valve assembly

FAIL-SAFE

Not changed from normal driving

DTC CONFIRMATION PROCEDURE

1. PREPARATION BEFORE WORK

If another "DTC CONFIRMATION PROCEDURE" occurs just before, turn ignition switch OFF and wait for at least 10 seconds, then perform the next test.

>> GO TO 2.

2. CHECK DTC DETECTION

Ⓜ With CONSULT

1. Start the engine.
2. Select "Data Monitor" in "TRANSMISSION".
3. Select "FLUID TEMP".
4. Maintain the following conditions for 10 seconds or more.

FLUID TEMP : More than -20°C (-4°F)

5. Check the first trip DTC.

Ⓜ With GST

1. Start the engine and wait for at least 10 seconds.

CAUTION:

When the ambient temperature is less than -20°C (-4°F) and the engine is cold, warm up the engine for approximately 5 minutes.

2. Check the first trip DTC.

Is "P084D" detected?

YES >> Go to [TM-149, "Diagnosis Procedure"](#).

NO-1 >> To check malfunction symptom before repair: Refer to [GI-41, "Intermittent Incident"](#).

NO-2 >> Confirmation after repair: INSPECTION END

Diagnosis Procedure

INFOID:000000012436499

1. CHECK TCM INPUT SIGNALS

1. Turn ignition switch OFF.

P084D TRANSMISSION FLUID PRESSURE SEN/SW H

< DTC/CIRCUIT DIAGNOSIS >

[CVT: RE0F10H]

2. Start the engine.
3. Check voltage between TCM harness connector terminals.

+		-	Condition	Voltage
TCM				
Connector	Terminal			
F89	17	Ground	<ul style="list-style-type: none">• Selector lever: "N" position• At idle	0.9 V

Is the inspection result normal?

YES >> Check intermittent incident. Refer to [GI-41. "Intermittent Incident"](#).

NO >> GO TO 2.

2. CHECK PRIMARY PRESSURE SENSOR POWER CIRCUIT

1. Turn ignition switch OFF.
2. Connect TCM connector.
3. Disconnect CVT unit connector.
4. Check voltage between CVT unit harness connector terminal and ground.

+		-	Voltage (Approx.)
CVT unit			
Connector	Terminal		
F43	22	Ground	5.0 V

Is the inspection result normal?

YES >> GO TO 3.

NO >> Repair or replace malfunctioning parts.

3. CHECK PRIMARY PRESSURE SENSOR SIGNAL CIRCUIT

Check voltage between CVT unit harness connector terminal and ground.

+		-	Voltage (Approx.)
CVT unit			
Connector	Terminal		
F43	13	Ground	0 V

Is the inspection result normal?

YES >> There is malfunction of primary pressure sensor circuit. Replace transaxle assembly. Refer to [TM-212. "Removal and Installation"](#).

NO >> Repair or replace malfunctioning parts.

P0863 TCM COMMUNICATION

< DTC/CIRCUIT DIAGNOSIS >

[CVT: RE0F10H]

P0863 TCM COMMUNICATION

DTC Description

INFOID:000000012436500

DTC DETECTION LOGIC

DTC	CONSULT screen terms (Trouble diagnosis content)	DTC detection condition	
		Diagnosis condition	Engine is started
P0863	CONTROL UNIT (CAN) (TCM Communication Circuit)	Signal	—
		Threshold	An error is detected at the initial CAN diagnosis of TCM
		Diagnosis delay time	Within 1 second

POSSIBLE CAUSE

TCM

FAIL-SAFE

- Selector shock is large
- Start is slow
- Acceleration is slow
- Lock-up is not performed

DTC CONFIRMATION PROCEDURE

1. PREPARATION BEFORE WORK

If another "DTC CONFIRMATION PROCEDURE" occurs just before, turn ignition switch OFF and wait for at least 10 seconds, then perform the next test.

>> GO TO 2.

2. CHECK DTC DETECTION

1. Start the engine.
2. Check the DTC.

Is "P0863" detected?

YES >> Go to [TM-151, "Diagnosis Procedure"](#).

NO-1 >> To check malfunction symptom before repair: Refer to [GI-41, "Intermittent Incident"](#).

NO-2 >> Confirmation after repair: INSPECTION END

Diagnosis Procedure

INFOID:000000012436501

1. CHECK INTERMITTENT INCIDENT

Refer to [GI-41, "Intermittent Incident"](#).

Is the inspection result normal?

YES >> Replace TCM. Refer to [TM-191, "Removal and Installation"](#).

NO >> Repair or replace malfunctioning parts.

P0890 TCM

DTC Description

INFOID:000000012436502

DTC DETECTION LOGIC

DTC	CONSULT screen terms (Trouble diagnosis content)	DTC detection condition	
		Diagnosis condition	TCM power supply voltage: More than 11 V
P0890	TCM (Transmission Control Module Power Relay Sense Circuit Low)	Signal	—
		Threshold	Battery voltage: Less than 8.4 V
		Diagnosis delay time	Maintained for 1 second

POSSIBLE CAUSE

- Harness or connector [TCM power supply (back-up) circuit is open or shorted]
- TCM

FAIL-SAFE

- Selector shock is large
- Start is slow
- Acceleration is slow
- Lock-up is not performed
- Vehicle speed is not increased

DTC CONFIRMATION PROCEDURE

1. PREPARATION BEFORE WORK

If another "DTC CONFIRMATION PROCEDURE" occurs just before, turn ignition switch OFF and wait for at least 10 seconds, then perform the next test.

>> GO TO 2.

2. CHECK DTC DETECTION

1. Start the engine and wait for 5 seconds or more.
2. Check the DTC.

Is "P0890" detected?

- YES >> Go to [TM-152, "Diagnosis Procedure"](#).
- NO-1 >> To check malfunction symptom before repair: Refer to [GI-41, "Intermittent Incident"](#).
- NO-2 >> Confirmation after repair: INSPECTION END

Diagnosis Procedure

INFOID:000000012436503

1. CHECK TCM BATTERY POWER SUPPLY (BACK-UP) CIRCUIT

1. Turn ignition switch OFF.
2. Disconnect TCM connector.
3. Check voltage between TCM harness connector terminals and ground.

TCM		-	Voltage
Connector	Terminal		
F89	45	Ground	10 – 16 V
	46		

Is the inspection result normal?

- YES >> GO TO 3.
- NO >> GO TO 2.

2. DETECT MALFUNCTIONING ITEMS

P0890 TCM

< DTC/CIRCUIT DIAGNOSIS >

[CVT: RE0F10H]

Check the following items:

- Open or short circuit of harness between battery positive terminal and TCM connector terminals 45, and 46. A
- 10A fuse [No.60, located in the fuse, fusible link and relay box]. Refer to [PG-89, "Terminal Arrangement"](#).

Is the inspection result normal?

- YES >> Check intermittent incident. Refer to [GI-41, "Intermittent Incident"](#). B
- NO >> Repair or replace malfunctioning parts.

3.CHECK INTERMITTENT INCIDENT

Refer to [GI-41, "Intermittent Incident"](#). C

Is the inspection result normal?

- YES >> Replace the TCM. Refer to [TM-191, "Removal and Installation"](#). TM
- NO >> Repair or replace malfunctioning parts.

E

F

G

H

I

J

K

L

M

N

O

P

P0962 PRESSURE CONTROL SOLENOID A

< DTC/CIRCUIT DIAGNOSIS >

[CVT: RE0F10H]

P0962 PRESSURE CONTROL SOLENOID A

DTC Description

INFOID:000000012436504

DTC DETECTION LOGIC

DTC	CONSULT screen terms (Trouble diagnosis content)	DTC detection condition	
P0962	PC SOLENOID A (Pressure Control Solenoid A Control Circuit Low)	Diagnosis condition	TCM power supply voltage: More than 11 V
		Signal	—
		Threshold	TCM judges that solenoid valve circuit is shorted to ground
		Diagnosis delay time	Maintained for 1 second

POSSIBLE CAUSE

- Harness or connector (Line pressure solenoid valve circuit is shorted to ground)
- Line pressure solenoid valve

FAIL-SAFE

- Selector shock is large
- Start is slow
- Acceleration is slow
- Lock-up is not performed

DTC CONFIRMATION PROCEDURE

1. PREPARATION BEFORE WORK

If another "DTC CONFIRMATION PROCEDURE" occurs just before, turn ignition switch OFF and wait for at least 10 seconds, then perform the next test.

>> GO TO 2.

2. CHECK DTC DETECTION

1. Start the engine and wait for 5 seconds or more.
2. Check the first trip DTC.

Is "P0962" detected?

- YES >> Go to [TM-154, "Diagnosis Procedure"](#).
NO-1 >> To check malfunction symptom before repair: Refer to [GI-41, "Intermittent Incident"](#).
NO-2 >> Confirmation after repair: INSPECTION END

Diagnosis Procedure

INFOID:000000012436505

1. CHECK CIRCUIT BETWEEN TCM AND CVT UNIT

1. Turn ignition switch OFF.
2. Disconnect TCM connector and CVT unit connector.
3. Check continuity between TCM harness connector terminal and ground.

TCM		—	Continuity
Connector	Terminal		
F89	30	Ground	Not existed

Is the inspection result normal?

- YES >> GO TO 2.
NO >> Repair or replace damaged parts.

2. CHECK LINE PRESSURE SOLENOID VALVE CIRCUIT

Check resistance between CVT unit harness connector terminal and ground.

P0962 PRESSURE CONTROL SOLENOID A

< DTC/CIRCUIT DIAGNOSIS >

[CVT: RE0F10H]

CVT unit		—	Condition	Resistance
Connector	Terminal			
F209	1	Ground	CVT fluid temperature: 20°C (68°F)	5.5 – 7.0 Ω
			CVT fluid temperature: 50°C (122°F)	6.0 – 8.0 Ω
			CVT fluid temperature: 80°C (176°F)	6.5 – 8.5 Ω

Is the inspection result normal?

YES >> Check intermittent incident. Refer to [GI-41. "Intermittent Incident"](#).

NO >> There is malfunction of line pressure solenoid valve circuit. Replace transaxle assembly. Refer to [TM-212. "Removal and Installation"](#).

A
B
C
TM
E
F
G
H
I
J
K
L
M
N
O
P

P0963 PRESSURE CONTROL SOLENOID A

< DTC/CIRCUIT DIAGNOSIS >

[CVT: RE0F10H]

P0963 PRESSURE CONTROL SOLENOID A

DTC Description

INFOID:000000012436506

DTC DETECTION LOGIC

DTC	CONSULT screen terms (Trouble diagnosis content)	DTC detection condition	
P0963	PC SOLENOID A (Pressure Control Solenoid A Control Circuit High)	Diagnosis condition	When all of the following conditions are satisfied: • TCM power supply voltage: More than 11 V • P0962 is not detected
		Signal	—
		Threshold	TCM judges that solenoid valve circuit is open
		Diagnosis delay time	Maintained for 1 second

POSSIBLE CAUSE

- Harness or connector (Line pressure solenoid valve circuit is open or shorted to power supply)
- Line pressure solenoid valve

FAIL-SAFE

- Selector shock is large
- Start is slow
- Acceleration is slow
- Lock-up is not performed

DTC CONFIRMATION PROCEDURE

1. PREPARATION BEFORE WORK

If another "DTC CONFIRMATION PROCEDURE" occurs just before, turn ignition switch OFF and wait for at least 10 seconds, then perform the next test.

>> GO TO 2.

2. CHECK DTC DETECTION

1. Start the engine and wait for 5 seconds or more.
2. Check the first trip DTC.

Is "P0963" detected?

YES >> Go to [TM-156. "Diagnosis Procedure"](#).

NO-1 >> To check malfunction symptom before repair: Refer to [GI-41. "Intermittent Incident"](#).

NO-2 >> Confirmation after repair: INSPECTION END

Diagnosis Procedure

INFOID:000000012436507

1. CHECK CIRCUIT BETWEEN TCM AND CVT UNIT

1. Turn ignition switch OFF.
2. Disconnect TCM connector and CVT unit connector.
3. Check continuity between TCM harness connector terminal and ground.

TCM		CVT unit		Continuity
Connector	Terminal	Connector	Terminal	
F89	30	F43	1	Existed

Is the inspection result normal?

YES >> GO TO 2.

NO >> Repair or replace damaged parts.

P0963 PRESSURE CONTROL SOLENOID A

< DTC/CIRCUIT DIAGNOSIS >

[CVT: RE0F10H]

2. CHECK LINE PRESSURE SOLENOID VALVE CIRCUIT

Check resistance between CVT unit harness connector terminal and ground.

CVT unit		—	Condition	Resistance
Connector	Terminal			
F209	1	Ground	CVT fluid temperature: 20°C (68°F)	5.5 – 7.0 Ω
			CVT fluid temperature: 50°C (122°F)	6.0 – 8.0 Ω
			CVT fluid temperature: 80°C (176°F)	6.5 – 8.5 Ω

Is the inspection result normal?

YES >> Check intermittent incident. Refer to [GI-41, "Intermittent Incident"](#).

NO >> There is malfunction of line pressure solenoid valve circuit. Replace transaxle assembly. Refer to [TM-212, "Removal and Installation"](#).

A
B
C
TM
E
F
G
H
I
J
K
L
M
N
O
P

P0965 PRESSURE CONTROL SOLENOID B

< DTC/CIRCUIT DIAGNOSIS >

[CVT: RE0F10H]

P0965 PRESSURE CONTROL SOLENOID B

DTC Description

INFOID:000000012436508

DTC DETECTION LOGIC

DTC	CONSULT screen terms (Trouble diagnosis content)	DTC detection condition		
P0965	PC SOLENOID B (Pressure Control Solenoid B Control Circuit Range Performance)	1	Diagnosis condition	When all of the following conditions are satisfied: <ul style="list-style-type: none"> • DTC other than the applicable DTC is not detected. • Engine speed: More than 625 rpm • Selector lever: Other than P/N position • CVT fluid temperature: More than -20°C (-4°F) • TCM power supply: More than 11 V • The difference between instruction pressure of primary pressure and 10-msec-ago instruction primary pressure is 0 MPa or more • Instruction pressure of primary pressure: 0.86 MPa or more • Instruction pressure of primary pressure - primary pressure: More than 1.2 MPa
			Signal	—
			Threshold	When all of the following conditions are satisfied and this state is maintained for 1 second: <ul style="list-style-type: none"> • DTC other than the applicable DTC is not detected. • CVT fluid temperature: More than -20°C (-4°F) • Selector lever: Other than P/N position • Engine speed: More than 625 rpm • Instruction pressure of primary pressure: More than 2 MPa • Primary pressure: 0.4 MPa or less
			Diagnosis delay time	Maintained for 10 seconds
		2	Diagnosis condition	When all of the following conditions are satisfied: <ul style="list-style-type: none"> • DTC other than the applicable DTC is not detected. • CVT fluid temperature: More than -20°C (-4°F) • Selector lever: Other than P/N position • TCM power supply: More than 11 V • The difference between instruction pressure of primary pressure and 10-msec-ago instruction primary pressure is 0 MPa or more • Primary pressure - instruction pressure of primary pressure: More than 1.2 MPa
			Signal	—
			Threshold	When all of the following conditions are satisfied and this state is maintained for 5.5 seconds: <ul style="list-style-type: none"> • DTC other than the applicable DTC is not detected. • CVT fluid temperature: More than -20°C (-4°F) • Selector lever: Other than P/N position • Primary pressure - instruction pressure of primary pressure: 1.2 MPa or more
			Diagnosis delay time	Maintained for 10 seconds

POSSIBLE CAUSE

- Harness or connector (Primary pressure solenoid valve circuit is open or shorted)
- Primary pressure solenoid valve

FAIL-SAFE

- When a malfunction occurs on the low oil pressure side

P0965 PRESSURE CONTROL SOLENOID B

< DTC/CIRCUIT DIAGNOSIS >

[CVT: RE0F10H]

- Selector shock is large
- Start is slow
- Acceleration is slow
- Lock-up is not performed
- When a malfunction occurs on the high oil pressure side
- Selector shock is large
- Lock-up is not performed

A

B

DTC CONFIRMATION PROCEDURE

C

1. PREPARATION BEFORE WORK

If another "DTC CONFIRMATION PROCEDURE" occurs just before, turn ignition switch OFF and wait for at least 10 seconds, then perform the next test.

TM

>> GO TO 2.

2. CHECK DTC DETECTION

E

1. Start the engine.
2. Drive the vehicle.
3. Maintain the following conditions for 20 seconds or more.

F

Vehicle speed : 40 km/h (25 MPH) or more

G

4. Stop the vehicle.
5. Check the first trip DTC.

Is "P0965" detected?

H

YES >> Go to [TM-159, "Diagnosis Procedure"](#).

NO-1 >> To check malfunction symptom before repair: Refer to [GI-41, "Intermittent Incident"](#).

NO-2 >> Confirmation after repair: INSPECTION END

I

Diagnosis Procedure

INFOID:000000012436509

1. CHECK INTERMITTENT INCIDENT

J

Refer to [GI-41, "Intermittent Incident"](#).

Is the inspection result normal?

K

YES >> Replace transaxle assembly. Refer to [TM-212, "Removal and Installation"](#).

NO >> Repair or replace malfunctioning parts.

L

M

N

O

P

P0966 PRESSURE CONTROL SOLENOID B

< DTC/CIRCUIT DIAGNOSIS >

[CVT: RE0F10H]

P0966 PRESSURE CONTROL SOLENOID B

DTC Description

INFOID:000000012436510

DTC DETECTION LOGIC

DTC	CONSULT screen terms (Trouble diagnosis content)	DTC detection condition	
P0966	PC SOLENOID B (Pressure Control Solenoid B Control Circuit Low)	Diagnosis condition	TCM power supply voltage: More than 11 V
		Signal	—
		Threshold	TCM judges that solenoid valve circuit is shorted to ground
		Diagnosis delay time	Maintained for 1 second

POSSIBLE CAUSE

- Harness or connector (Primary pressure solenoid valve circuit shorted to ground)
- Primary pressure solenoid valve

FAIL-SAFE

- Selector shock is large
- Start is slow
- Acceleration is slow
- Lock-up is not performed

DTC CONFIRMATION PROCEDURE

1. PREPARATION BEFORE WORK

If another "DTC CONFIRMATION PROCEDURE" occurs just before, turn ignition switch OFF and wait for at least 10 seconds, then perform the next test.

>> GO TO 2.

2. CHECK DTC DETECTION

1. Start the engine and wait for 5 seconds or more.
2. Check the first trip DTC.

Is "P0966" detected?

YES >> Go to [TM-160, "Diagnosis Procedure"](#).

NO-1 >> To check malfunction symptom before repair: Refer to [GI-41, "Intermittent Incident"](#).

NO-2 >> Confirmation after repair: INSPECTION END

Diagnosis Procedure

INFOID:000000012436511

1. CHECK CIRCUIT BETWEEN TCM AND CVT UNIT

1. Turn ignition switch OFF.
2. Disconnect TCM connector and CVT unit connector.
3. Check continuity between TCM harness connector terminal and ground.

TCM		—	Continuity
Connector	Terminal		
F89	40	Ground	Not existed

Is the inspection result normal?

YES >> GO TO 2.

NO >> Repair or replace damaged parts.

2. CHECK PRIMARY PRESSURE SOLENOID VALVE CIRCUIT

Check resistance between CVT unit harness connector terminal and ground.

P0966 PRESSURE CONTROL SOLENOID B

< DTC/CIRCUIT DIAGNOSIS >

[CVT: RE0F10H]

CVT unit		—	Condition	Resistance
Connector	Terminal			
F209	2	Ground	CVT fluid temperature: 20°C (68°F)	5.5 – 7.0 Ω
			CVT fluid temperature: 50°C (122°F)	6.0 – 8.0 Ω
			CVT fluid temperature: 80°C (176°F)	6.5 – 8.5 Ω

Is the inspection result normal?

- YES >> Check intermittent incident. Refer to [GI-41. "Intermittent Incident"](#).
- NO >> There is malfunction of primary pressure solenoid valve circuit. Replace transaxle assembly. Refer to [TM-212. "Removal and Installation"](#).

A
B
C
TM
E
F
G
H
I
J
K
L
M
N
O
P

P0967 PRESSURE CONTROL SOLENOID B

< DTC/CIRCUIT DIAGNOSIS >

[CVT: RE0F10H]

P0967 PRESSURE CONTROL SOLENOID B

DTC Description

INFOID:000000012436512

DTC DETECTION LOGIC

DTC	CONSULT screen terms (Trouble diagnosis content)	DTC detection condition	
P0967	PC SOLENOID B (Pressure Control Solenoid B Control Circuit High)	Diagnosis condition	When all of the following conditions are satisfied: <ul style="list-style-type: none">• TCM power supply voltage: More than 11 V• P0966 is not detected
		Signal	—
		Threshold	TCM judges that solenoid valve circuit is open
		Diagnosis delay time	Maintained for 1 second

POSSIBLE CAUSE

- Harness or connector (Primary pressure solenoid valve circuit open or shorted to power supply)
- Primary pressure solenoid valve

FAIL-SAFE

- Selector shock is large
- Start is slow
- Acceleration is slow
- Lock-up is not performed

DTC CONFIRMATION PROCEDURE

1. PREPARATION BEFORE WORK

If another "DTC CONFIRMATION PROCEDURE" occurs just before, turn ignition switch OFF and wait for at least 10 seconds, then perform the next test.

>> GO TO 2.

2. CHECK DTC DETECTION

1. Start the engine and wait for 5 seconds or more.
2. Check the first trip DTC.

Is "P0967" detected?

YES >> Go to [TM-162, "Diagnosis Procedure"](#).

NO-1 >> To check malfunction symptom before repair: Refer to [GI-41, "Intermittent Incident"](#).

NO-2 >> Confirmation after repair: INSPECTION END

Diagnosis Procedure

INFOID:000000012436513

1. CHECK CIRCUIT BETWEEN TCM AND CVT UNIT

1. Turn ignition switch OFF.
2. Disconnect TCM connector and CVT unit connector.
3. Check continuity between TCM harness connector terminal and ground.

TCM		CVT unit		Continuity
Connector	Terminal	Connector	Terminal	
F89	40	F43	2	Existed

Is the inspection result normal?

YES >> GO TO 2.

NO >> Repair or replace damaged parts.

P0967 PRESSURE CONTROL SOLENOID B

< DTC/CIRCUIT DIAGNOSIS >

[CVT: RE0F10H]

2. CHECK PRIMARY PRESSURE SOLENOID VALVE CIRCUIT

Check resistance between CVT unit harness connector terminal and ground.

CVT unit		—	Condition	Resistance
Connector	Terminal			
F209	2	Ground	CVT fluid temperature: 20°C (68°F)	5.5 – 7.0 Ω
			CVT fluid temperature: 50°C (122°F)	6.0 – 8.0 Ω
			CVT fluid temperature: 80°C (176°F)	6.5 – 8.5 Ω

Is the inspection result normal?

YES >> Check intermittent incident. Refer to [GI-41, "Intermittent Incident"](#).

NO >> There is malfunction of primary pressure solenoid valve circuit. Replace transaxle assembly. Refer to [TM-212, "Removal and Installation"](#).

A
B
C
TM
E
F
G
H
I
J
K
L
M
N
O
P

P2765 INPUT SPEED SENSOR B

< DTC/CIRCUIT DIAGNOSIS >

[CVT: RE0F10H]

P2765 INPUT SPEED SENSOR B

DTC Description

INFOID:000000012436514

DTC DETECTION LOGIC

DTC	CONSULT screen terms (Trouble diagnosis content)	DTC detection condition	
P2765	INPUT SPEED SENSOR B (Input/Turbine Speed Sensor B Circuit)	Diagnosis condition	When any of 1, 2 or 3 is satisfied: <ol style="list-style-type: none"> 1. When all of the following conditions are satisfied and this state is maintained for 5 seconds: <ul style="list-style-type: none"> - Secondary pulley speed: Less than 149 rpm - Primary pulley speed: 1,000 rpm or more 2. When all of the following conditions are satisfied and this state is maintained for 0.5 seconds: <ul style="list-style-type: none"> - 10-msec-ago secondary pulley speed: 1000 rpm or more - Now secondary pulley speed: 0 rpm 3. When all of the following conditions are satisfied and this state is maintained for 5 seconds: <ul style="list-style-type: none"> - Range: D or L - Engine speed: 450 rpm or more - Primary pulley speed: 300 rpm or more - Secondary pulley speed: 300 rpm or more - Input speed: 300 rpm or more - The difference between engine speed and primary pulley speed is 1,000 rpm or less - The difference between engine speed and input speed is 1,000 rpm or less - The difference between primary pulley speed and input speed is 1,000 rpm or less - Lock-up command is being given (except for slip lock-up) - DTC other than the applicable DTC is not detected. - When any of following items are satisfied: <ul style="list-style-type: none"> • Primary pulley speed/secondary pulley speed: More than 2.9 • Primary pulley speed/secondary pulley speed: Less than 0.3
		Signal	—
		Threshold	When all of the following conditions are satisfied: <ul style="list-style-type: none"> • TCM power supply voltage: More than 11 V • After range change completion, it spends 2 seconds or more.
		Diagnosis delay time	Maintained for 5 seconds

POSSIBLE CAUSE

- Harness or connector (Output speed sensor circuit is open or shorted)
- Output speed sensor

FAIL-SAFE

- Start is slow

P2765 INPUT SPEED SENSOR B

[CVT: RE0F10H]

< DTC/CIRCUIT DIAGNOSIS >

- Acceleration is slow
- Lock-up is not performed
- Manual mode is not activated

DTC CONFIRMATION PROCEDURE

CAUTION:

Be careful of the driving speed.

1. PREPARATION BEFORE WORK

If another "DTC CONFIRMATION PROCEDURE" occurs just before, turn ignition switch OFF and wait for at least 10 seconds, then perform the next test.

>> GO TO 2.

2. CHECK DTC DETECTION

1. Start the engine.
2. Drive the vehicle.
3. Maintain the following conditions for 10 seconds or more.

Selector lever : "D" position
 Engine speed : 1,200 rpm or more
 Vehicle speed : 55 km/h (34 MPH) or more

4. Stop the vehicle.
5. Check the first trip DTC.

Is "P2765" detected?

- YES >> Go to [TM-165, "Diagnosis Procedure"](#).
 NO-1 >> To check malfunction symptom before repair: Refer to [GI-41, "Intermittent Incident"](#).
 NO-2 >> Confirmation after repair: INSPECTION END

Diagnosis Procedure

INFOID:000000012436515

1. CHECK OUTPUT SPEED SENSOR POWER CIRCUIT

1. Turn ignition switch OFF.
2. Disconnect output speed sensor connector.
3. Turn ignition switch ON.
4. Check voltage between output speed sensor harness connector terminal and ground.

+		-	Voltage
Output speed sensor			
Connector	Terminal		
F23	3	Ground	10 – 16 V

Is the inspection result normal?

- YES >> GO TO 2.
 NO >> GO TO 6.

2. CHECK OUTPUT SPEED SENSOR GROUND CIRCUIT

Check continuity between output speed sensor harness connector terminal and ground.

Output speed sensor		—	Continuity
Connector	Terminal		
F23	1	Ground	Existed

Is the inspection result normal?

- YES >> GO TO 3.
 NO >> Repair or replace malfunctioning parts.

P2765 INPUT SPEED SENSOR B

< DTC/CIRCUIT DIAGNOSIS >

[CVT: RE0F10H]

3. CHECK CIRCUIT BETWEEN OUTPUT SPEED SENSOR AND TCM (PART 1)

1. Turn ignition switch OFF.
2. Disconnect TCM connector.
3. Check continuity between output speed sensor harness connector terminal and TCM harness connector terminal.

Output speed sensor		TCM		Continuity
Connector	Terminal	Connector	Terminal	
F23	2	F89	34	Existed

Is the inspection result normal?

- YES >> GO TO 4.
 NO >> Repair or replace malfunctioning parts.

4. CHECK CIRCUIT BETWEEN OUTPUT SPEED SENSOR AND TCM (PART 2)

Check continuity between output speed sensor harness connector terminal and ground.

Output speed sensor		—	Continuity
Connector	Terminal		
F23	2	Ground	Not existed

Is the inspection result normal?

- YES >> GO TO 5.
 NO >> Repair or replace malfunctioning parts.

5. CHECK TCM INPUT SIGNALS

1. Connect all of disconnected connectors.
2. Lift the vehicle.
3. Start the engine.
4. Check frequency of output speed sensor.

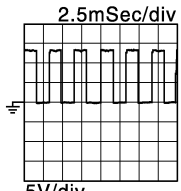
+		-	Condition	Frequency (Approx.)
TCM				
Connector	Terminal			
F89	34	Ground	<ul style="list-style-type: none"> Selector lever: "M1" position Vehicle speed: 20 km/h (12 MPH) 	<p>200 Hz</p> <p>2.5mSec/div</p>  <p>5V/div</p> <p style="text-align: right; font-size: small;">JSDIA1897GB</p>

Is the inspection result normal?

- YES >> Check intermittent incident. Refer to [GI-41, "Intermittent Incident"](#).
 NO >> Replace output speed sensor. Refer to [TM-203, "Removal and Installation"](#).

6. DETECT MALFUNCTIONING ITEMS

Check the following items:

- Harness open circuit or short circuit between ignition switch and IPDM E/R. Refer to [PG-40, "Wiring Diagram - IGNITION POWER SUPPLY -"](#).
- Harness open circuit or short circuit between IPDM E/R connector terminal 61 and output speed sensor connector terminal 3.
- 10A fuse (No.43, located in the IPDM E/R). Refer to [PG-91, "Fuse, Connector and Terminal Arrangement"](#).
- IPDM E/R

Is the check result normal?

- YES >> Check intermittent incident. Refer to [GI-41, "Intermittent Incident"](#).

P2765 INPUT SPEED SENSOR B

< DTC/CIRCUIT DIAGNOSIS >

[CVT: RE0F10H]

NO >> Repair or replace malfunctioning parts.

A

B

C

TM

E

F

G

H

I

J

K

L

M

N

O

P

P2813 SELECT SOLENOID

< DTC/CIRCUIT DIAGNOSIS >

[CVT: RE0F10H]

P2813 SELECT SOLENOID

DTC Description

INFOID:000000012436516

DTC DETECTION LOGIC

DTC	CONSULT screen terms (Trouble diagnosis content)	DTC detection condition		
P2813	SELECT SOLENOID (Select solenoid)	1	Diagnosis condition	—
			Signal	—
			Threshold	When all the following conditions are established <ul style="list-style-type: none"> • DTC other than the applicable DTC is not detected. • Throttle position: More than 6.27 deg. • Vehicle speed: Less than 3 km/h (1 MPH) • CVT fluid temperature: More than 20°C (68°F) • Selector lever: Other than P, N • Turbine speed when performed N → D, N (P) → R: More than 500 rpm • TCM power supply voltage: More than 11 V - Detection time <ul style="list-style-type: none"> • N → D: 0.4 seconds • N → R: 0.3 seconds • P → R: 0.3 seconds
			Diagnosis delay time	Three times in 1DC
		2	Diagnosis condition	—
			Signal	—
			Threshold	When all of the following conditions are satisfied: <ul style="list-style-type: none"> • Selector lever: Other than P, N • Vehicle speed: Less than 3 km/h (1 MPH) • Differences between primary pulley speed and secondary speed: Less than 120 rpm • Clutch instructions pressure: 0.95 MPa or more • Differences between turbine speed and input speed: Less than 200 rpm • Turbine speed – speed: More than 450 rpm • DTC other than the applicable DTC is not detected. • TCM power supply voltage: More than 11 V
			Diagnosis delay time	The counting of time continues while all of the following conditions are satisfied and stops when the conditions become unsatisfied (the count is maintained). When accumulated time reaches 30 seconds (Clutch is judged as engaged and the count is reset.)

NOTE:

DC stands for “DRIVING CYCLE” and indicates a series of driving cycle of “Ignition switch OFF → ON → driving → OFF”.

POSSIBLE CAUSE

Select solenoid valve

FAIL-SAFE

- When a malfunction occurs on the low oil pressure side
 - Selector shock is large
 - Start is slow
 - Acceleration is slow
 - Vehicle speed is not increased
- When a malfunction occurs on the high oil pressure side
 - Selector shock is large

P2813 SELECT SOLENOID

< DTC/CIRCUIT DIAGNOSIS >

[CVT: RE0F10H]

DTC CONFIRMATION PROCEDURE

CAUTION:

Be careful of the driving speed.

1. PREPARATION BEFORE WORK

If another "DTC CONFIRMATION PROCEDURE" occurs just before, turn ignition switch OFF and wait for at least 10 seconds, then perform the next test.

>> GO TO 2.

2. CHECK DTC DETECTION 1

1. Start the engine.
2. Maintain the following conditions. (Keep 30 seconds or more after the selector lever shifted.)

Selector lever : N → D, N → R, P → R

3. Check the first trip DTC.

Is "P2813" detected?

YES >> Go to [TM-169, "Diagnosis Procedure"](#).

NO-1 >> To check malfunction symptom before repair: Refer to [GI-41, "Intermittent Incident"](#).

NO-2 >> Confirmation after repair: INSPECTION END

Diagnosis Procedure

INFOID:000000012436517

1. CHECK INTERMITTENT INCIDENT

Refer to [GI-41, "Intermittent Incident"](#).

Is the inspection result normal?

YES >> Replace transaxle assembly. Refer to [TM-212, "Removal and Installation"](#).

NO >> Repair or replace malfunctioning parts.

P2814 SELECT SOLENOID

< DTC/CIRCUIT DIAGNOSIS >

[CVT: RE0F10H]

P2814 SELECT SOLENOID

DTC Description

INFOID:000000012436518

DTC DETECTION LOGIC

DTC	CONSULT screen terms (Trouble diagnosis content)	DTC detection condition	
P2814	SELECT SOLENOID (Select solenoid)	Diagnosis condition	TCM power supply voltage: 11 V or more
		Signal	—
		Threshold	TCM judges that solenoid valve circuit is shorted to ground
		Diagnosis delay time	Maintained for 1 second

POSSIBLE CAUSE

- Harness or connector (Select solenoid valve circuit shorted to ground)
- Select solenoid valve

FAIL-SAFE

Selector shock is large

DTC CONFIRMATION PROCEDURE

CAUTION:

Be careful of the driving speed.

1. PREPARATION BEFORE WORK

If another "DTC CONFIRMATION PROCEDURE" occurs just before, turn ignition switch OFF and wait for at least 10 seconds, then perform the next test.

>> GO TO 2.

2. CHECK DTC DETECTION

1. Start the engine.
2. Maintain the following conditions. (Keep 5 seconds or more after the selector lever shifted.)

Selector lever : N → D, N → R, P → R

3. Check the first trip DTC.

Is "P2814" detected?

- YES >> Go to [TM-170, "Diagnosis Procedure"](#).
- NO-1 >> To check malfunction symptom before repair: Refer to [GI-41, "Intermittent Incident"](#).
- NO-2 >> Confirmation after repair: INSPECTION END

Diagnosis Procedure

INFOID:000000012436519

1. CHECK CIRCUIT BETWEEN TCM AND CVT UNIT

1. Turn ignition switch OFF.
2. Disconnect TCM connector and CVT unit connector.
3. Check continuity between TCM harness connector terminal and ground.

TCM		—	Continuity
Connector	Terminal		
F89	37	Ground	Not existed

Is the inspection result normal?

- YES >> GO TO 2.
- NO >> Repair or replace damaged parts.

P2814 SELECT SOLENOID

< DTC/CIRCUIT DIAGNOSIS >

[CVT: RE0F10H]

2. CHECK SELECT SOLENOID VALVE CIRCUIT

Check resistance between CVT unit harness connector terminal and ground.

CVT unit		—	Condition	Resistance
Connector	Terminal			
F209	4	Ground	CVT fluid temperature: 20°C (68°F)	5.5 – 7.0 Ω
			CVT fluid temperature: 50°C (122°F)	6.0 – 8.0 Ω
			CVT fluid temperature: 80°C (176°F)	6.5 – 8.5 Ω

Is the inspection result normal?

YES >> Check intermittent incident. Refer to [GI-41. "Intermittent Incident"](#).

NO >> There is malfunction of select solenoid valve circuit. Replace transaxle assembly. Refer to [TM-212. "Removal and Installation"](#).

A
B
C
TM
E
F
G
H
I
J
K
L
M
N
O
P

P2815 SELECT SOLENOID

< DTC/CIRCUIT DIAGNOSIS >

[CVT: RE0F10H]

P2815 SELECT SOLENOID

DTC Description

INFOID:000000012436520

DTC DETECTION LOGIC

DTC	CONSULT screen terms (Trouble diagnosis content)	DTC detection condition	
P2815	SELECT SOLENOID (Select solenoid)	Diagnosis condition	When all of the following conditions are satisfied: <ul style="list-style-type: none">• TCM power supply voltage: More than 11 V• P2814 is not detected
		Signal	—
		Threshold	TCM judges that solenoid valve circuit is open
		Diagnosis delay time	Maintained for 1 second

POSSIBLE CAUSE

- Harness or connector (Select solenoid valve circuit open or shorted to power supply)
- Select solenoid valve

FAIL-SAFE

Selector shock is large

DTC CONFIRMATION PROCEDURE

1. PREPARATION BEFORE WORK

If another "DTC CONFIRMATION PROCEDURE" occurs just before, turn ignition switch OFF and wait for at least 10 seconds, then perform the next test.

>> GO TO 2.

2. CHECK DTC DETECTION

1. Start the engine.
2. Maintain the following conditions. (Keep 5 seconds or more after the selector lever shifted.)

Selector lever : N → D, N → R, P → R

3. Check the first trip DTC.

Is "P2815" detected?

YES >> Go to [TM-172, "Diagnosis Procedure"](#).

NO-1 >> To check malfunction symptom before repair: Refer to [GI-41, "Intermittent Incident"](#).

NO-2 >> Confirmation after repair: INSPECTION END

Diagnosis Procedure

INFOID:000000012436521

1. CHECK CIRCUIT BETWEEN TCM AND CVT UNIT

1. Turn ignition switch OFF.
2. Disconnect TCM connector and CVT unit connector.
3. Check continuity between TCM harness connector terminal and ground.

TCM		CVT unit		Continuity
Connector	Terminal	Connector	Terminal	
F89	37	F43	4	Existed

Is the inspection result normal?

YES >> GO TO 2.

NO >> Repair or replace damaged parts.

P2815 SELECT SOLENOID

< DTC/CIRCUIT DIAGNOSIS >

[CVT: RE0F10H]

2. CHECK SELECT SOLENOID VALVE CIRCUIT

Check resistance between CVT unit harness connector terminal and ground.

CVT unit		—	Condition	Resistance
Connector	Terminal			
F209	4	Ground	CVT fluid temperature: 20°C (68°F)	5.5 – 7.0 Ω
			CVT fluid temperature: 50°C (122°F)	6.0 – 8.0 Ω
			CVT fluid temperature: 80°C (176°F)	6.5 – 8.5 Ω

Is the inspection result normal?

YES >> Check intermittent incident. Refer to [GI-41. "Intermittent Incident"](#).

NO >> There is malfunction of select solenoid valve circuit. Replace transaxle assembly. Refer to [TM-212. "Removal and Installation"](#).

A
B
C
TM
E
F
G
H
I
J
K
L
M
N
O
P

MAIN POWER SUPPLY AND GROUND CIRCUIT

< DTC/CIRCUIT DIAGNOSIS >

[CVT: RE0F10H]

MAIN POWER SUPPLY AND GROUND CIRCUIT

Diagnosis Procedure

INFOID:000000011973006

1. CHECK TCM POWER CIRCUIT (PART 1)

1. Turn ignition switch OFF.
2. Disconnect TCM connector.
3. Check voltage between TCM harness connector terminals and ground.

+		-	Voltage
TCM			
Connector	Terminal	Ground	10 – 16 V
F89	45		
	46		

Is the inspection result normal?

- YES >> GO TO 2.
NO >> GO TO 4.

2. CHECK TCM POWER CIRCUIT (PART 2)

Check voltage between TCM harness connector terminals and ground.

+		-	Condition	Voltage			
TCM							
Connector	Terminal	Ground	Ignition switch ON	10 – 16 V			
F89	47				Ground	Ignition switch OFF	Approx. 0 V
						48	Ignition switch ON
	48						Ignition switch OFF

Is the inspection result normal?

- YES >> GO TO 3.
NO >> GO TO 5.

3. CHECK TCM GROUND CIRCUIT

Check continuity between TCM harness connector terminals and ground.

TCM		—	Continuity
Connector	Terminal		
F89	41	Ground	Existed
	42		

Is the inspection result normal?

- YES >> Check intermittent incident. Refer to [GI-41, "Intermittent Incident"](#).
NO >> Repair or replace malfunctioning parts.

4. DETECT MALFUNCTION ITEMS (PART 1)

Check the following items:

- Open or short circuit in harness between battery positive terminal and TCM connector terminal 45, and 46.
- 10A fuse (No.60, located in the fuse, fusible link and relay box). Refer to [PG-89, "Terminal Arrangement"](#).

Is the inspection result normal?

- YES >> Check intermittent incident. Refer to [GI-41, "Intermittent Incident"](#).
NO >> Repair or replace malfunctioning parts.

5. CHECK CIRCUIT BETWEEN IPDM E/R AND TCM (PART 1)

MAIN POWER SUPPLY AND GROUND CIRCUIT

< DTC/CIRCUIT DIAGNOSIS >

[CVT: RE0F10H]

1. Turn ignition switch OFF.
2. Disconnect IPDM E/R connector.
3. Check continuity between IPDM E/R harness connector terminal and TCM harness connector terminals.

IPDM E/R		TCM		Continuity
Connector	Terminal	Connector	Terminal	
F50	61	F89	47	Existed
			48	

Is the check result normal?

YES >> GO TO 6.

NO >> Repair or replace malfunctioning parts.

6. CHECK CIRCUIT BETWEEN IPDM E/R AND TCM (PART 2)

Check continuity between IPDM E/R harness connector terminal and ground.

IPDM E/R		—	Continuity
Connector	Terminal		
F50	61	Ground	Not existed

Is the check result normal?

YES >> GO TO 7.

NO >> Repair or replace malfunctioning parts.

7. DETECT MALFUNCTIONING ITEMS (PART 2)

Check the following items:

- Open or short circuit in harness between ignition switch and IPDM E/R. Refer to [PCS-23, "Wiring Diagram"](#).
- 10A fuse (No.43, located in the IPDM E/R). Refer to [PG-91, "Fuse, Connector and Terminal Arrangement"](#).
- IPDM E/R

Is the check result normal?

YES >> Check intermittent incident. Refer to [GI-41, "Intermittent Incident"](#).

NO >> Repair or replace malfunctioning parts.

A
B
C
TM
E
F
G
H
I
J
K
L
M
N
O
P

SHIFT POSITION INDICATOR CIRCUIT

< DTC/CIRCUIT DIAGNOSIS >

[CVT: RE0F10H]

SHIFT POSITION INDICATOR CIRCUIT

Component Parts Function Inspection

INFOID:000000011973007

1. CHECK SHIFT POSITION INDICATOR

1. Start the engine.
2. Shift selector lever.
3. Check that the selector lever position and the shift position indicator on the combination meter are identical.

Is the inspection result normal?

- YES >> INSPECTION END
NO >> Go to [TM-176, "Diagnosis Procedure"](#).

Diagnosis Procedure

INFOID:000000011973008

1. CHECK TCM INPUT/OUTPUT SIGNAL

Ⓟ With CONSULT

1. Start the engine.
2. Select "Data Monitor" in "TRANSMISSION".
3. Select "RANGE".
4. Shift selector lever.
5. Check that selector lever position, "RANGE" on CONSULT screen, and shift position indicator display on combination meter are identical.

Is the check result normal?

- YES >> INSPECTION END
NO-1 ("RANGE" is changed but is not displayed on shift position indicator.)>>Check "Self Diagnostic Result" in "TRANSMISSION".
NO-2 ("RANGE" and shift position indicator are different.)>>Check "Self Diagnostic Result" in "TRANSMISSION".
NO-3 (Specific "RANGE" is not displayed on shift position indicator.)>>Check "Self Diagnostic Result" in "METER/M&A".

SHIFT LOCK SYSTEM

< DTC/CIRCUIT DIAGNOSIS >

[CVT: RE0F10H]

SHIFT LOCK SYSTEM

Component Function Check

INFOID:000000012260900

1. CHECK SHIFT LOCK OPERATION (PART 1)

1. Turn ignition ON.
2. Shift the selector lever to "P" (Park) position.
3. Attempt to shift the selector lever to any other position with the brake pedal released.

Can the selector lever be shifted to any other position?

- YES >> Refer to [TM-177, "Diagnosis Procedure"](#).
NO >> GO TO 2.

2. CHECK SHIFT LOCK OPERATION (PART 2)

Attempt to shift the selector lever to any other position with the brake pedal depressed.

Can the selector lever be shifted to any other position?

- YES >> Inspection End.
NO >> Refer to [TM-177, "Diagnosis Procedure"](#).

Diagnosis Procedure

INFOID:000000012260901

Regarding Wiring Diagram information, refer to [TM-70, "Wiring Diagram"](#).

1. CHECK POWER SOURCE

1. Turn ignition switch OFF.
2. Disconnect BCM connector M18.
3. Check voltage between BCM connector M18 terminal 27 and ground while pressing the brake pedal.

BCM		Ground	Condition	Voltage (Approx.)
Connector	Terminal		Brake pedal depressed	Battery voltage
M18	27			

Is the inspection result normal?

- YES >> GO TO 3.
NO >> GO TO 2.

2. CHECK STOP LAMPS

Do the stop lamps operate normally?

Is the inspection result normal?

- YES >> Check the following:
- Harness between fuse block (J/B) and BCM.
 - Fuse block (J/B).
- NO >> Refer to [TM-70, "Wiring Diagram"](#).

3. CHECK HARNESS BETWEEN BCM AND CVT SHIFT SELECTOR

1. Disconnect CVT shift selector connector.
2. Check continuity between BCM connector M80 terminal 108 and CVT shift selector connector M78 terminal 3.

BCM		CVT shift selector		Continuity
Connector	Terminal	Connector	Terminal	
M80	108	M78	3	Yes

3. Check continuity between BCM connector M80 terminal 108 and ground.

SHIFT LOCK SYSTEM

< DTC/CIRCUIT DIAGNOSIS >

[CVT: RE0F10H]

BCM		Ground	Continuity
Connector	Terminal		
M80	108		No

Is the inspection result normal?

- YES >> GO TO 4.
- NO >> Repair or replace harness or connector.

4.CHECK GROUND CIRCUIT (CVT SHIFT SELECTOR)

Check continuity between CVT shift selector connector M78 terminal 4 and ground.

CVT shift selector		Ground	Continuity
Connector	Terminal		
M78	4		Yes

Is the inspection result normal?

- YES >> Replace CVT shift selector. Refer to [TM-185, "Removal and Installation"](#).
- NO >> Repair or replace harness or connector.

Component Inspection (Shift Lock Solenoid)

INFOID:0000000012260902

1.CHECK SHIFT LOCK SOLENOID

Apply voltage to terminals of shift lock solenoid and park position switch (shift selector) connector and check that shift lock solenoid is activated.

CAUTION:

- Connect the fuse between the terminals when applying the voltage.
- Never cause shorting between terminals.

+ (fuse)	-	Condition	Status
Shift lock solenoid			
Terminals			
3	4	Apply 12 V between terminals 3 and 4 with the park position switch (shift selector) in the "P" (park) position.	Shift lock solenoid operates

Is the inspection result normal?

- YES >> Inspection End.
- NO >> Replace CVT shift selector. Refer to [TM-185, "Removal and Installation"](#).

Component Inspection (Park Position Switch)

INFOID:0000000012260903

1.CHECK PARK POSITION SWITCH (SHIFT SELECTOR)

Apply voltage to terminals of shift lock solenoid and park position switch (shift selector) connector and check that shift lock solenoid is activated.

CAUTION:

- Connect the fuse between the terminals when applying the voltage.
- Never cause shorting between terminals.

+ (fuse)	-	Condition	Status
Shift lock solenoid			
Terminals			
3	4	Apply 12 V between terminals 3 and 4 with the park position switch (shift selector) in the "P" (park) position.	Shift lock solenoid operates

Is the inspection result normal?

SHIFT LOCK SYSTEM

< DTC/CIRCUIT DIAGNOSIS >

[CVT: RE0F10H]

- YES >> Inspection End.
- NO >> Replace CVT shift selector. Refer to [TM-185. "Removal and Installation"](#).

Component Inspection (Stop Lamp Switch)

INFOID:0000000012260904

1. CHECK STOP LAMP SWITCH

Check the continuity between the stop lamp switch connector terminals.

Stop lamp switch		Condition	Continuity
Terminals			
1	2	Depressed brake pedal	Yes
		Released brake pedal	No

Is the inspection result normal?

- YES >> Inspection End.
- NO >> Replace stop lamp switch. Refer to [BR-20. "Exploded View"](#).

A
B
C
TM
E
F
G
H
I
J
K
L
M
N
O
P

CVT CONTROL SYSTEM

< SYMPTOM DIAGNOSIS >

[CVT: RE0F10H]

SYMPTOM DIAGNOSIS

CVT CONTROL SYSTEM

Symptom Table

INFOID:000000011973014

- The diagnosis item number indicates the order of check. Start checking in the order from 1.
- Perform diagnoses of symptom table 1 before symptom table 2.

Symptom Table 1

Symptom		Engine system											Stall test	CVT position	Power supply	Control valve	CVT fluid level and state	Ignition switch and starter
		EC-150	CAN communication line (U1000)	Transmission range switch (P0705, P0706)	Input speed sensor (P0717)	Primary speed sensor (P0715)	Output speed sensor (P2765)	CVT fluid temperature sensor (P0711, P0712, P0713)	Primary pressure sensor (P084C, P084D)	Secondary pressure sensor (P0841, P0847, P0848)	Torque converter clutch solenoid valve (P0740, P0743, P0744)	TM-58						
Shift Shock	Large shock (N→ D position)	1	4	7				3			6		2		8	5		
	Large shock (N→ R position)	1	4	7				3			6		2		8	5		
	Shock is too large for lock-up.	2	3								6		1		5	4		
Slips/Will Not Engage	Vehicle cannot be started from D position.	8	3		5	6	7	9	10	11		4	2	12	13	1		
	Vehicle cannot be started from R position.	8	3		5	6	7	9	10	11		4	2	12	13	1		
	Does not lock-up.	2	6	8	3	4	10	9	11	12	5	7			13	1		
	Does not hold lock-up condition.	2	6	8	3	4	10	9	11	12	5	7			13	1		
	Lock-up is not released.	2	6		3	4					5	7			8	1		
	With selector lever in D position, acceleration is extremely poor.	3	4	5	7	8	9	12	10	11		2	6	13	14	1		
	With selector lever in R position, acceleration is extremely poor.	3	4	5	7	8	9	12	10	11		2	6	13	14	1		
Slips at lock-up.	2	6	8	3	4	10	9	11	12	5	7			13	1			

CVT CONTROL SYSTEM

< SYMPTOM DIAGNOSIS >

[CVT: RE0F10H]

Symptom	Engine system												Stall test	CVT position	Power supply	Control valve	CVT fluid level and state	Ignition switch and starter
	CAN communication line (U1000)	Transmission range switch (P0705, P0706)	Input speed sensor (P0717)	Primary speed sensor (P0715)	Output speed sensor (P2765)	CVT fluid temperature sensor (P0711, P0712, P0713)	Primary pressure sensor (P084C, P084D)	Secondary pressure sensor (P0841, P0847, P0848)	Torque converter clutch solenoid valve (P0740, P0743, P0744)									
	<u>EC-150</u>												<u>TM-84</u>	<u>TM-85</u>	<u>TM-174</u>	<u>TM-195</u>	<u>TM-82</u>	<u>PG-40, STR-10, STR-14</u>
Other	No creep at all.	2	4	3	7	8	9	10	11	12			5	6	13	14	1	
	Vehicle cannot run in any position.	8		2	5	6	7	9	10	11			3	4	12	13	1	
	With selector lever in D position, driving is not possible.	8		2	5	6	7	9	10	11			3	4	12	13	1	
	With selector lever in R position, driving is not possible.	8		2	5	6	7	9	10	11			3	4	12	13	1	
	Judder occurs during lock-up.	2	6		3	4	5									8	1	
	Strange noise in D position.	2	3													4	1	
	Strange noise in R position.	2	3													4	1	
	Strange noise in N position.	2	3													4	1	
	Vehicle does not decelerate by engine brake.	7	3		4	5	6							2		8	1	
	Maximum speed low.	2	3		5	6	7		8	9	11		4			10	1	
	With selector lever in P position, vehicle does not enter parking condition or, with selector lever in another position, parking condition is not cancelled.			1											2			
	Vehicle runs with CVT in P position.			1											3	4	2	
	Vehicle runs with CVT in N position.			1											3	4	2	
	Engine stall.	2	6		3	4				8	9	5	7			10	1	
	Engine stalls when selector lever shifted N → D or R.	2	6		3	4										7	1	
	Engine speed does not return to idle.	2	4				3									5	1	
Engine does not start in N or P position.			3											2			1	

A
B
C
TM
E
F
G
H
I
J
K
L
M
N
O
P

CVT CONTROL SYSTEM

< SYMPTOM DIAGNOSIS >

[CVT: RE0F10H]

Symptom Table 2

Symptom		Torque converter	Transmission range switch	Oil pump	Forward clutch	Reverse brake	Planetary gear	Bearings	Parking mechanism	Stop lamp switch	Shift lock solenoid	CVT shift selector
		TM-215	TM-212						BR-12	TM-177	TM-185	
Shift Shock	Large shock (N→ D position)		2		1							
	Large shock (N→ R position)		2			1						
	Shock is too large for lock-up.	1										
Slips/Will Not Engage	Vehicle cannot be started from D position.		3	1	2							
	Vehicle cannot be started from R position.		4	1		2			3			
	Does not lock-up.	1	3	2								
	Does not hold lock-up condition.	1	3	2								
	Lock-up is not released.	1		2								
	With selector lever in D position, acceleration is extremely poor.	1	3		2							
	With selector lever in R position, acceleration is extremely poor.	1	4	2			3					
Slips at lock-up.	1		2									

CVT CONTROL SYSTEM

< SYMPTOM DIAGNOSIS >

[CVT: RE0F10H]

Symptom	Torque converter	Transmission range switch	Oil pump	Forward clutch	Reverse brake	Planetary gear	Bearings	Parking mechanism	Stop lamp switch	Shift lock solenoid	CVT shift selector	
	TM-215	TM-212							BR-12	TM-177	TM-185	
Other	No creep at all.	1	6	2	4	5	3					A
	Vehicle cannot run in all positions.	1		2	4	5	3		6			B
	With selector lever in D position, driving is not possible.	1		2	4		3		5			C
	With selector lever in R position, driving is not possible.	1		2		4	3		5			D
	Judder occurs during lock-up.	1										E
	Strange noise in D position.	1		2	4		3	5				F
	Strange noise in R position.	1		2		4	3					G
	Strange noise in N position.	1		2			3					H
	Maximum speed low.	1	5	2	4		3					I
	With selector lever in P position, vehicle does not enter parking condition or, with selector lever in another position, parking condition is not cancelled.								1			J
	Vehicle runs with CVT in P position.						2		1			K
	Vehicle runs with CVT in N position.				2	3	1					L
	Engine stall.	1										M
	Engine stalls when selector lever shifted N → D or R.	1										N
	When brake pedal is depressed with ignition switch ON, selector-lever cannot be shifted from P position to other position.									1	2	3
When brake pedal is not depressed with ignition switch ON, selector lever can be shifted from P position to other position.									1	2	3	P

PERIODIC MAINTENANCE

CVT FLUID

Inspection

INFOID:0000000011973015

FLUID LEAKAGE

- Check transaxle surrounding area (oil seal and plug etc.)for fluid leakage.
- If anything is found, repair or replace damaged parts and adjust CVT fluid level. Refer to [TM-82. "Adjustment"](#).

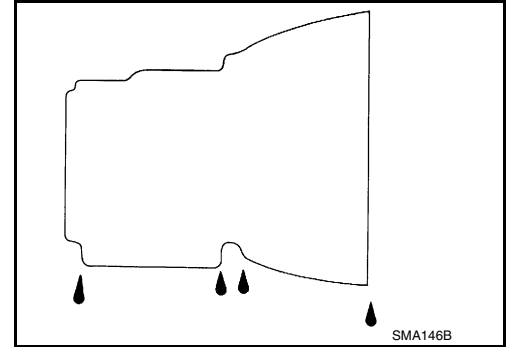

CVT SHIFT SELECTOR

< REMOVAL AND INSTALLATION >

[CVT: RE0F10H]

REMOVAL AND INSTALLATION

CVT SHIFT SELECTOR

Exploded View

INFOID:0000000011973016

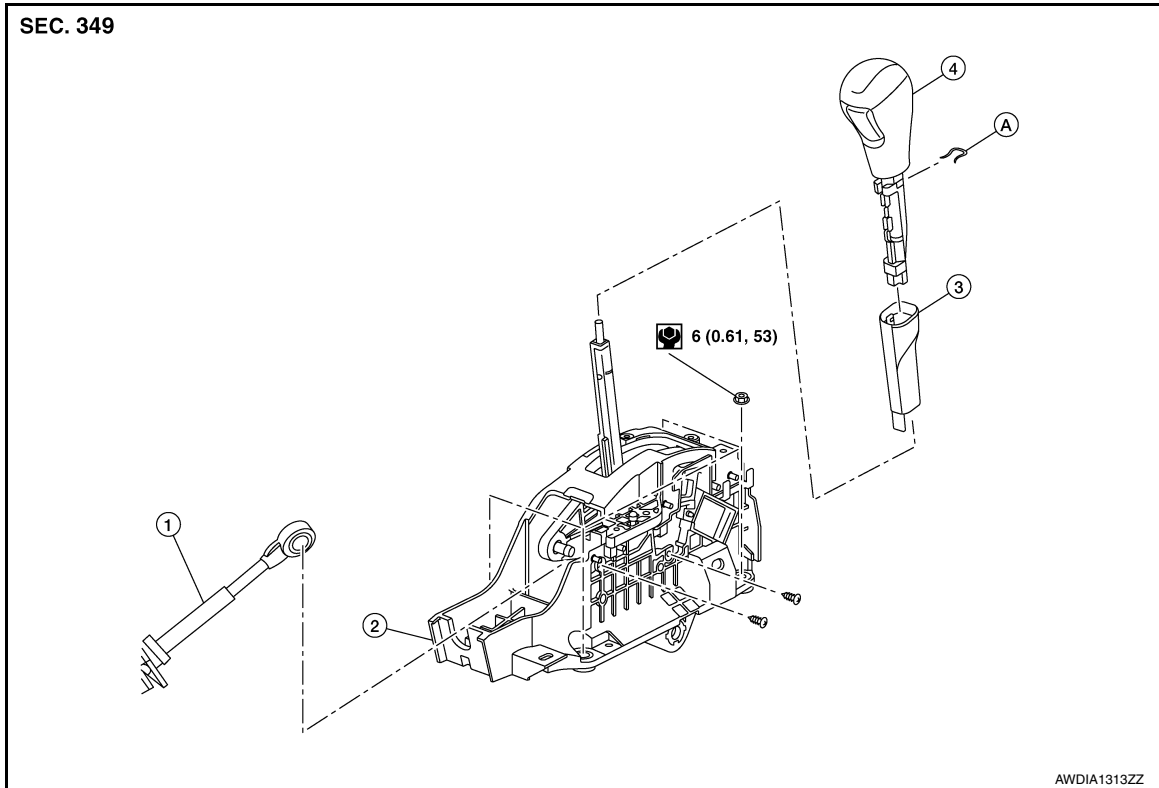

- 1. CVT Shift selector assembly
- 2. Control cable
- 3. Shift selector handle cover
- 4. Shift selector handle
- A. Shift selector handle clip

Removal and Installation

INFOID:0000000011973017

CAUTION:

Always apply the parking brake before removal and installation.

REMOVAL

1. Apply the parking brake.

CAUTION:

Make sure the vehicle cannot move with the parking brake applied.

2. Disconnect battery negative terminal. Refer to [PG-101. "Removal and Installation \(Battery\)"](#).
3. Remove shift lock override button cover (1) using suitable tool, and insert suitable tool into opening (A) to depress the shift lock override button. Move shift selector to "N" position while depressing shift lock override button.

↔: Front

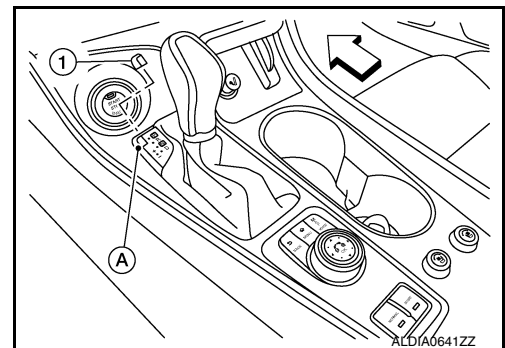

CVT SHIFT SELECTOR

[CVT: RE0F10H]

< REMOVAL AND INSTALLATION >

4. Remove the shift selector handle (1).
 - a. Release the shift selector handle cover (2) using a suitable tool from the base of the shift selector handle (1).
 - b. Remove the shift selector handle clip (A).
 - c. Pull upward and remove the shift selector handle (1).

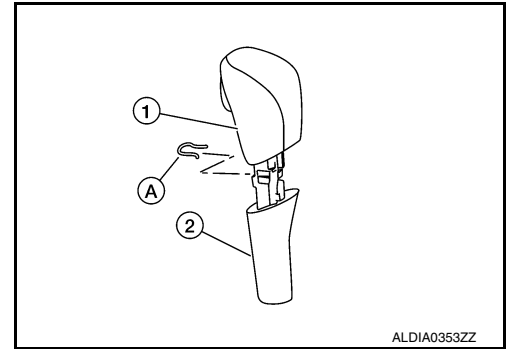

5. Remove the center console. Refer to [IP-20. "Removal and Installation"](#).
6. Release the harness clip, then disconnect the harness connector from shift selector.
7. Depress shift lock override button and move shift selector to "P" position.
8. Remove the control cable from the CVT shift selector assembly. Refer to [TM-187. "Removal and Installation"](#).
9. Remove the four CVT shift selector assembly nuts and the CVT shift selector assembly from the vehicle.

INSTALLATION

Installation is in the reverse order of removal.

- When installing control cable (1) to the shift selector assembly (2), check that control cable is fully pressed in until it stops with the ribbed surface (A) facing upward.

NOTE:

- Apply multi-purpose grease to control cable eye before installation.
- Adjust control cable as necessary. Refer to [TM-188. "Inspection and Adjustment"](#).

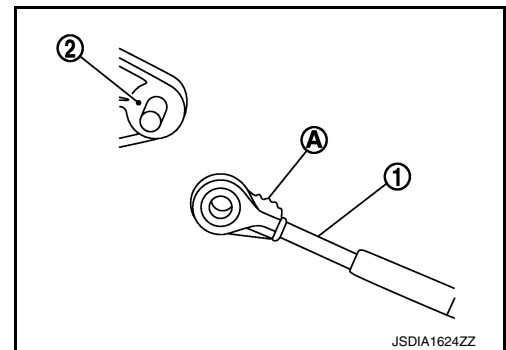

Inspection

INSPECTION AFTER INSTALLATION

Check the CVT shift selector position. Refer to [TM-85. "Inspection"](#).
If a malfunction is found, adjust the position. Refer to [TM-85. "Adjustment"](#).

INFOID:000000011973018

CONTROL CABLE

< REMOVAL AND INSTALLATION >

[CVT: RE0F10H]

CONTROL CABLE

Exploded View

INFOID:0000000011973019

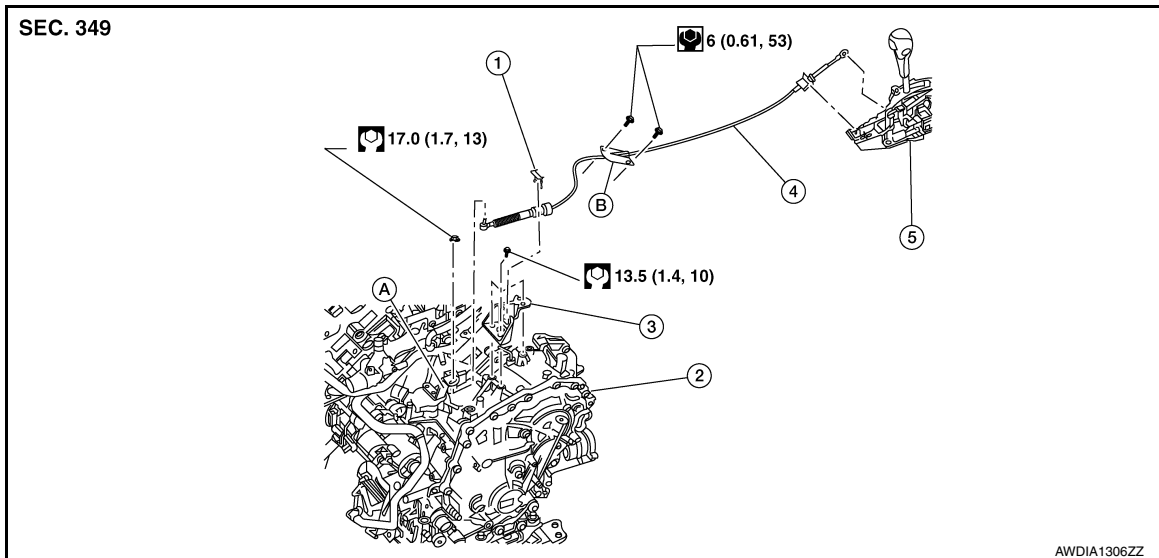

- | | | |
|---------------------|--------------------------------|-----------------|
| 1. Lock plate | 2. Transaxle assembly | 3. Bracket |
| 4. Control cable | 5. CVT shift selector assembly | A. Manual lever |
| B. Retainer grommet | | |

Removal and Installation

INFOID:0000000011973020

CAUTION:

Always apply the parking brake before performing removal and installation.

INSTALLATION

1. Apply the parking brake.

CAUTION:

Make sure the vehicle cannot move with the parking brake applied.

2. Remove the front air duct and air cleaner case assembly. Refer to [EM-26. "Removal and Installation"](#).
3. Remove the control cable nut (←), using suitable tool.
4. Remove control cable (2) from manual lever (A).
5. Remove the lock plate (3) from control cable (2).
6. Remove control cable (2) from bracket (1).

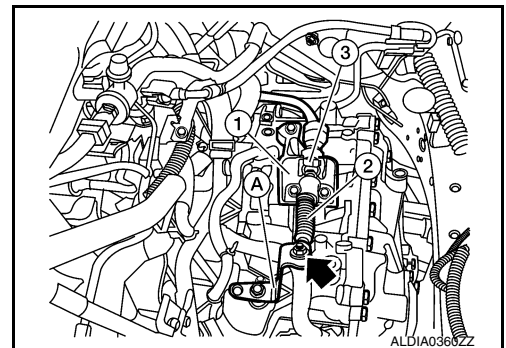

7. Remove center console. Refer to [IP-20. "Removal and Installation"](#).
8. Disconnect the around view monitor control unit harness connectors and remove the around view monitor control unit (if equipped). Refer to [AV-273. "Removal and Installation"](#).

CONTROL CABLE

< REMOVAL AND INSTALLATION >

[CVT: RE0F10H]

9. Remove control cable (1) from the CVT shift selector assembly (2).
(A): Ribbed surface

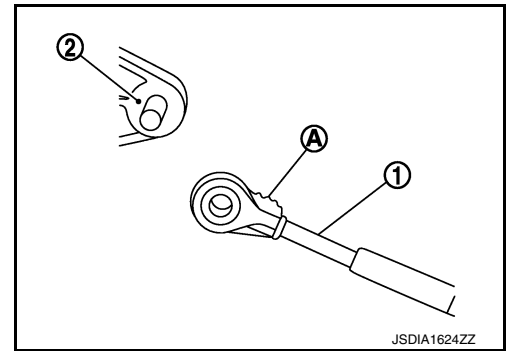

10. Pull back dash trim and remove two retainer grommet bolts.
11. Thread the control cable through the sheet metal and remove the control cable from the vehicle.

INSTALLATION

Installation is in the reverse order of removal.

- When installing control cable (1) to the CVT shift selector assembly (2), check that control cable is fully pressed in until it stops with the ribbed surface (A) facing upward.

NOTE:

- Apply multi-purpose grease to control cable eye before installation.
- Adjust control cable as necessary. Refer to [TM-188, "Inspection and Adjustment"](#).

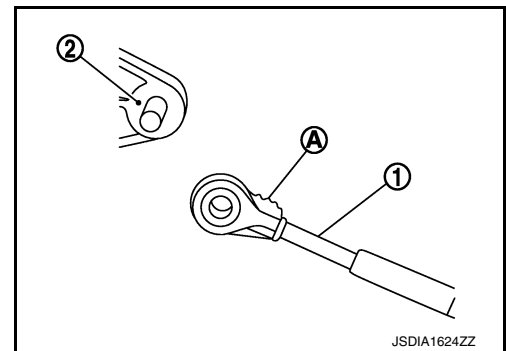

INFOID:000000011973021

Inspection and Adjustment

ADJUSTMENT AFTER INSTALLATION

Adjust the position. Refer to [TM-85, "Adjustment"](#).

INSPECTION AFTER ADJUSTMENT

Check the shift selector position after the adjustment. Refer to [TM-85, "Inspection"](#).

PADDLE SHIFTER

< REMOVAL AND INSTALLATION >

[CVT: RE0F10H]

PADDLE SHIFTER

Exploded View

INFOID:000000011973022

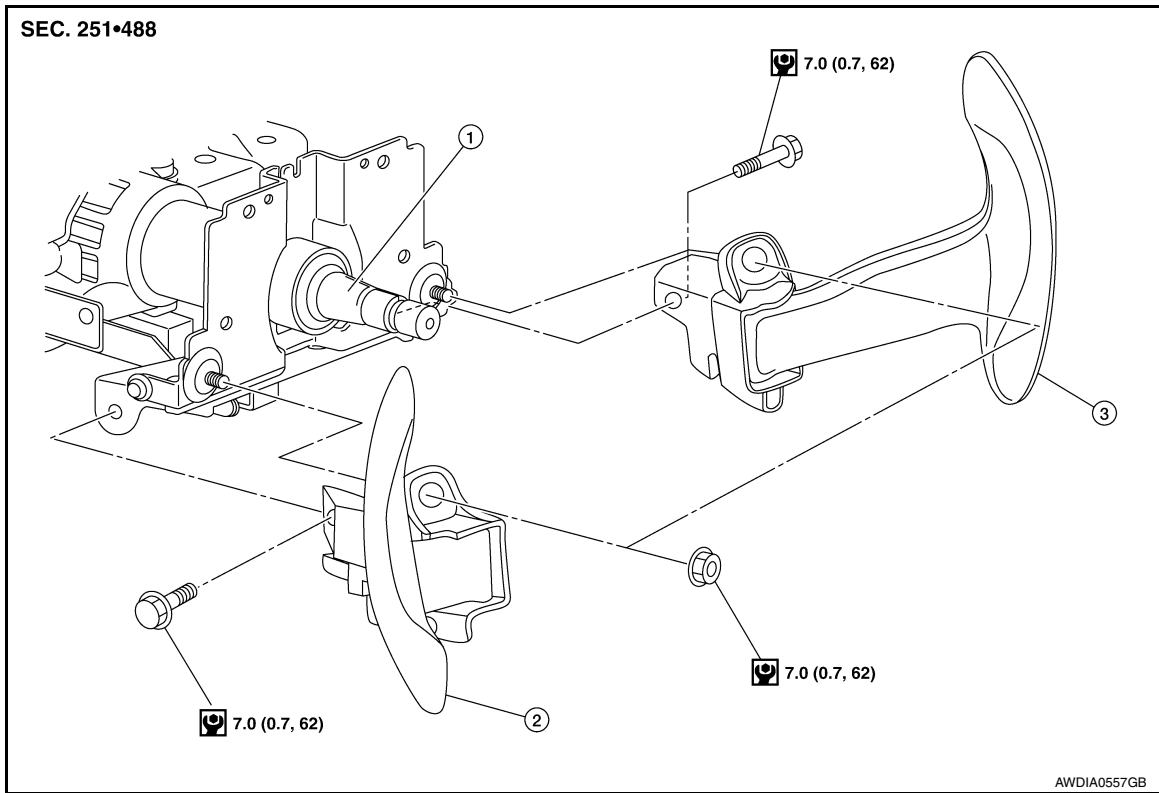

1. Steering column assembly 2. Paddle shifter (shift-down) 3. Paddle shifter (shift-up)

Removal and Installation

INFOID:000000011973023

REMOVAL

1. Park the vehicle on a level surface.
2. Remove the driver air bag module. Refer to [SR-12, "Removal and Installation"](#).
3. Remove the steering wheel. Refer to [ST-30, "Removal and Installation"](#).
4. Remove the column cover. Refer to [ST-32, "Removal and Installation"](#).

A
B
C
TM
E
F
G
H
I
J
K
L
M
N
O
P

PADDLE SHIFTER

[CVT: RE0F10H]

< REMOVAL AND INSTALLATION >

5. Remove the vehicle harness connector (C) and (D) from paddle shifter.
 - (A) : Side of paddle shifter (shift-down)
 - (B) : Side of paddle shifter (shift-up)
6. Remove the paddle shifter nuts and bolts (E) and nuts (F).
7. Remove the paddle shifter from the steering column assembly.

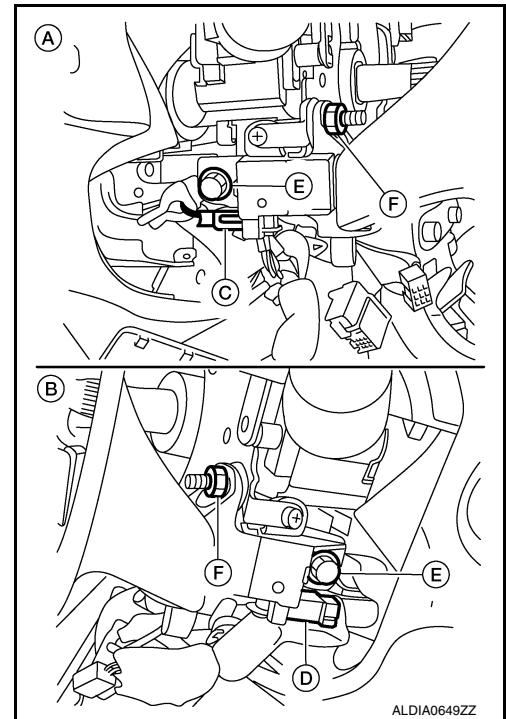

INSTALLATION

Installation is in the reverse order of removal.

TCM

Exploded View

INFOID:0000000011973024

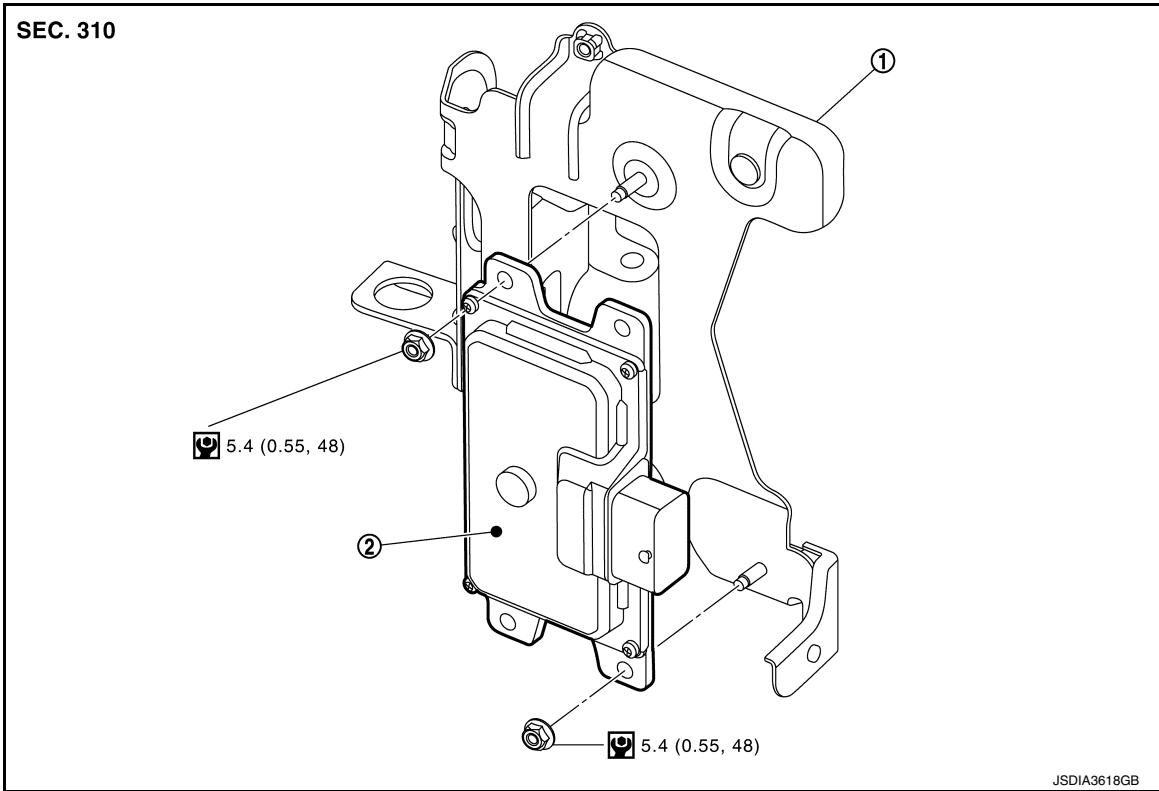

- 1. Bracket
- 2. TCM

Removal and Installation

INFOID:0000000011973025

CAUTION:

- Do not impact the TCM when removing or installing TCM.
- When replacing TCM, perform "ADDITIONAL SERVICE WHEN REPLACING TCM". Refer to [TM-76, "Description"](#).
- When replacing TCM and transaxle simultaneously, perform "ADDITIONAL SERVICE WHEN REPLACING TCM AND TRANSAXLE ASSEMBLY". Refer to [TM-79, "Description"](#).
- When replacing TCM, note the :CVTF DETERIORATION DATE" value displayed on CONSULT "CONFORM CVTF DETERIORATION" in MAINTANANCE BOOKLET, before starting the operation.

REMOVAL

1. Disconnect the battery negative terminal. Refer to [PG-101, "Removal and Installation \(Battery\)"](#).
2. Remove front air duct. Refer to [EM-26, "Removal and Installation"](#).
3. Disconnect the harness connector (A) from TCM (1).
4. Remove the TCM nuts and remove TCM (1) from bracket.

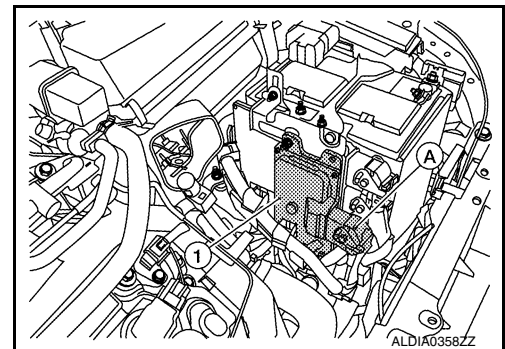

INSTALLATION

A
B
C
TM
E
F
G
H
I
J
K
L
M
N
O
P

TCM

< REMOVAL AND INSTALLATION >

[CVT: RE0F10H]

Installation is in the reverse order of removal.

Adjustment

INFOID:000000011973026

ADJUSTMENT AFTER INSTALLATION

Perform "ADDITIONAL SERVICE WHEN REPLACING TCM". Refer to [TM-76, "Description"](#).

AIR BREATHER HOSE

< REMOVAL AND INSTALLATION >

[CVT: RE0F10H]

AIR BREATHER HOSE

Exploded View

INFOID:000000012373746

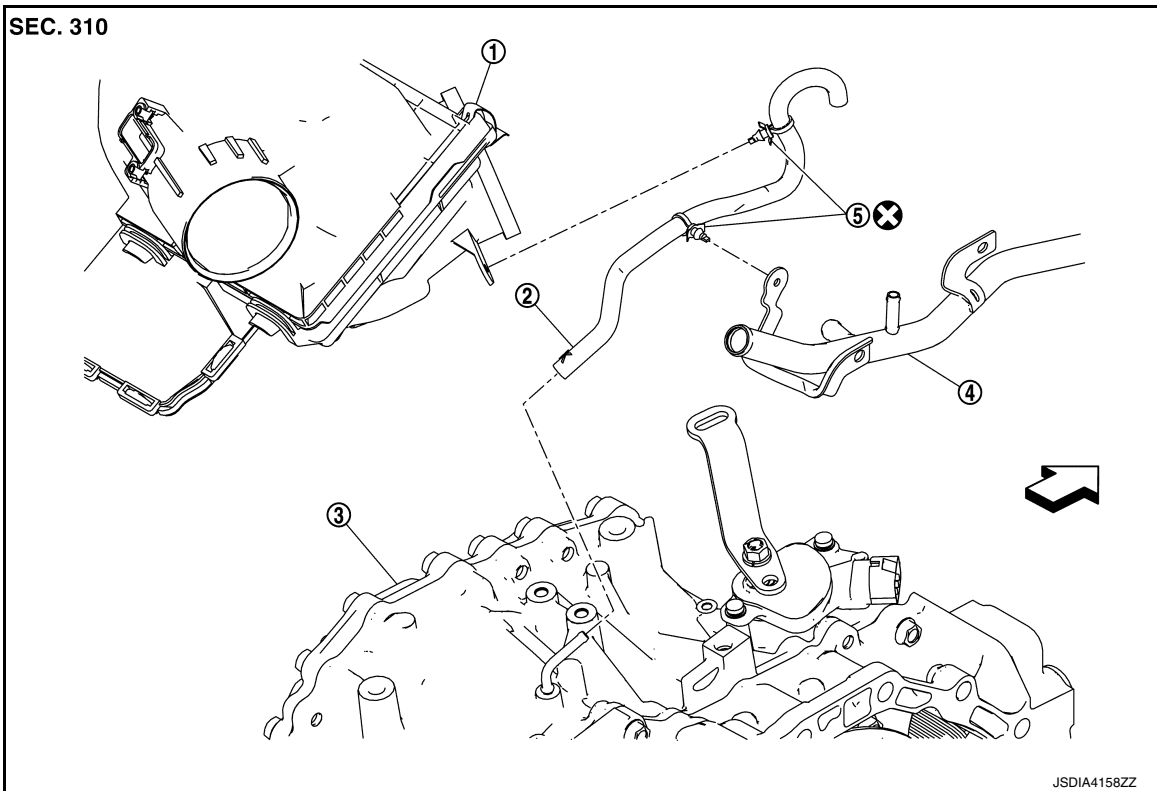

- 1. Air cleaner case
- 2. Air breather hose
- 3. Transaxle assembly
- 4. Heater pipe
- 5. Clip

← : Vehicle front

Removal and Installation

INFOID:000000011973027

REMOVAL

1. Remove the front air duct and air cleaner case cleaner. Refer to [EM-26. "Removal and Installation"](#).
2. Remove air breather hose (1) from transaxle assembly (2).

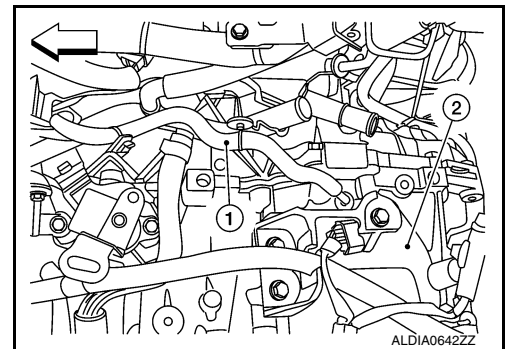

INSTALLATION

Installation is in the reverse order of removal.

CAUTION:

- Do not reuse clips.
- Check that air breather hose is not collapsed or blocked due to folding or bending when installed.

AIR BREATHER HOSE

< REMOVAL AND INSTALLATION >

[CVT: RE0F10H]

- Insert air breather hose (1) to air breather tube (2) all the way to the curve of the tube.
- Insert air breather hose to air breather tube so that the paint mark (A) is facing upward.

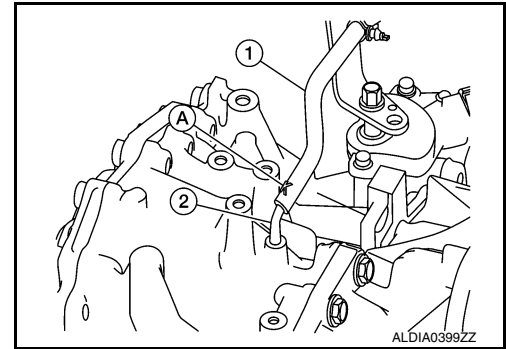

CONTROL VALVE

< REMOVAL AND INSTALLATION >

[CVT: RE0F10H]

CONTROL VALVE

Exploded View

INFOID:0000000011973028

COMPONENT PARTS LOCATION

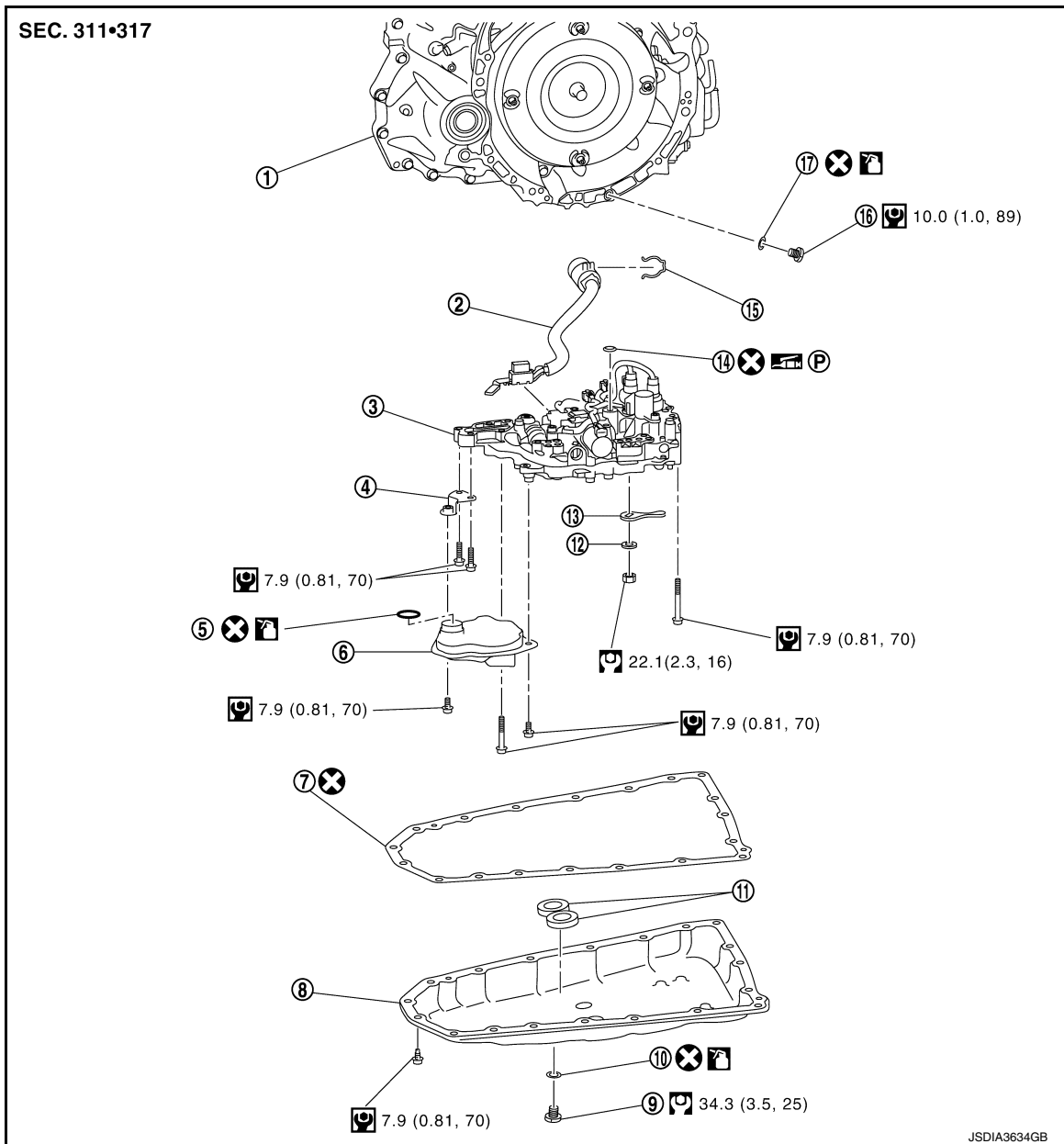

- | | | |
|-----------------------|---------------------------|--------------------------|
| 1. Transaxle assembly | 2. Terminal cord assembly | 3. Control valve |
| 4. Bracket | 5. O-ring | 6. Oil strainer assembly |
| 7. Oil pan gasket | 8. Oil pan | 9. Drain plug |
| 10. Drain plug gasket | 11. Magnet | 12. Spring washer |
| 13. Manual plate | 14. Lip seal | 15. Snap ring |
| 16. Overflow plug | 17. O-ring | |

Removal and Installation

INFOID:0000000011973029

REMOVAL

1. Disconnect battery negative terminal. Refer to [PG-101, "Removal and Installation \(Battery\)"](#).

CONTROL VALVE

[CVT: RE0F10H]

< REMOVAL AND INSTALLATION >

2. Remove engine under cover. Refer to [EXT-26. "Exploded View"](#)
3. Remove drain plug from oil pan and then drain the CVT fluid.
4. Remove drain plug gasket.
CAUTION:
Do not reuse drain plug gasket.
5. Remove the front fender side protector (LH). Refer to [EXT-28. "Exploded View"](#).
6. Disconnect the CVT unit harness connector.
7. Remove the snap ring (1) from the CVT unit harness connector (A).

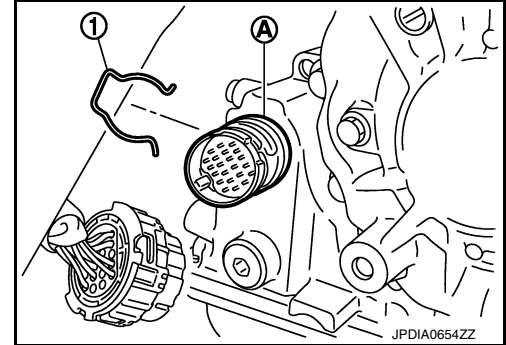

8. Press the CVT unit harness connector (A) into the transaxle case.
CAUTION:
Do not damage the CVT unit harness connector.
NOTE:
Clean around the harness connector to prevent foreign materials from entering into the transaxle case.

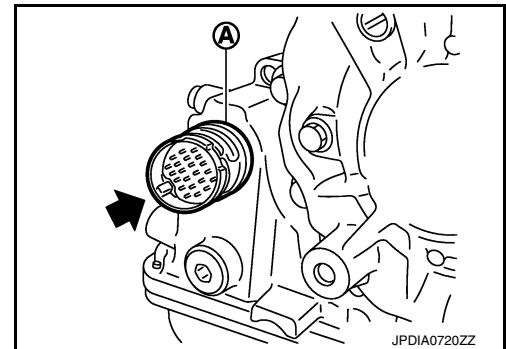

9. Remove the oil pan bolts, and then remove the oil pan and oil pan gasket.
CAUTION:
Do not reuse oil pan gasket.
10. Remove the magnets from the oil pan.
11. Remove the lock nut (1) and spring washer (2), and manual plate (3) from manual shaft (A).

⇐ : Front

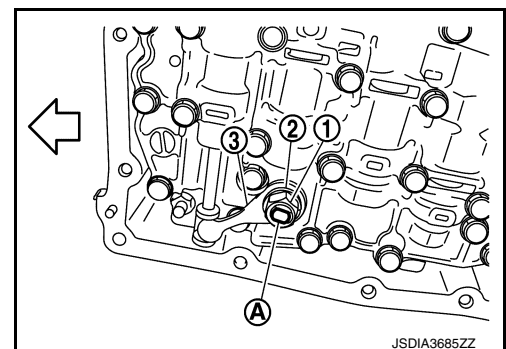

12. Remove CVT fluid temperature sensor bracket (1).

← : Bolt

⇐ : Front

13. Disconnect control valve harness connector (A).

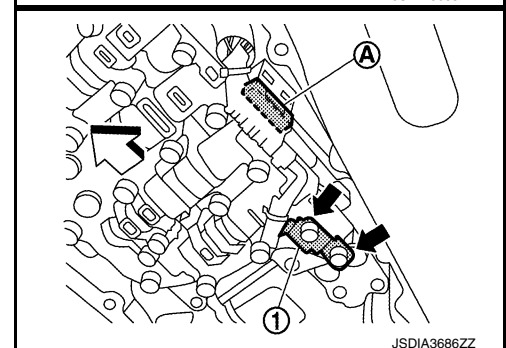

CONTROL VALVE

< REMOVAL AND INSTALLATION >

[CVT: RE0F10H]

14. Remove the oil strainer assembly bolts (A) and (B), and then remove the oil strainer assembly (1).

⇐ : Front

15. Remove O-ring from oil strainer assembly.

CAUTION:
Do not reuse O-ring.

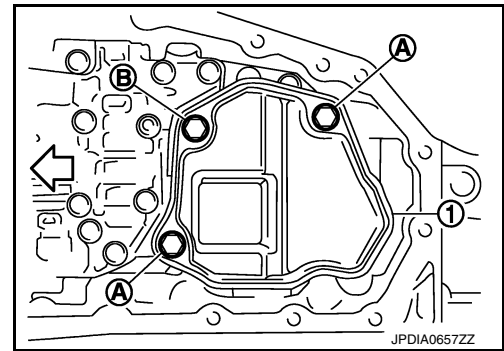

16. Remove the bracket (1).

← : Bolt

⇐ : Front

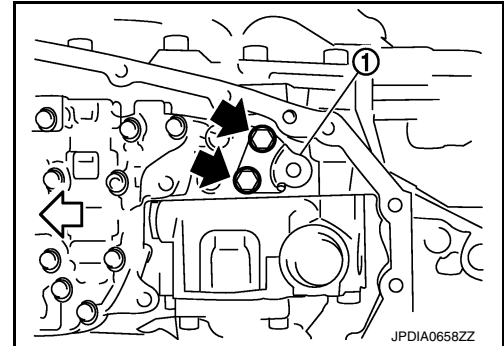

17. Remove the control valve bolts (A) and (B), and then remove the control valve from the transaxle case.

⇐ : Front

CAUTION:
Do not drop the control valve, ratio control valve and manual shaft.

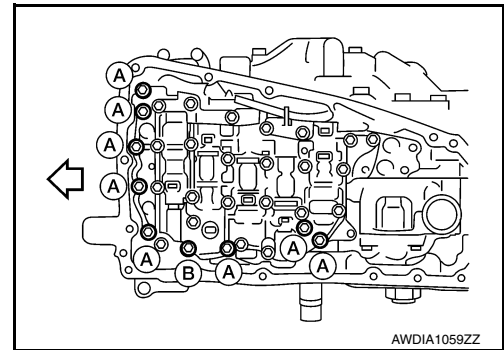

18. Remove terminal cord assembly (1) from inside the transaxle case.

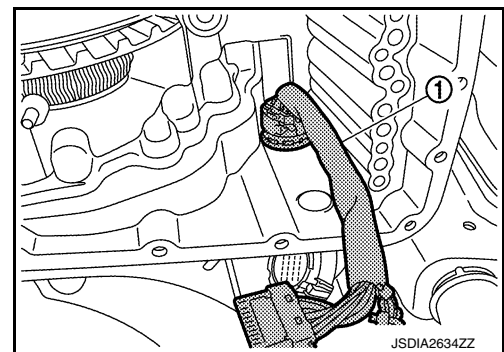

19. Remove the lip seal (1) from the transaxle case.

CAUTION:
Do not reuse lip seal.

⇐ : Front

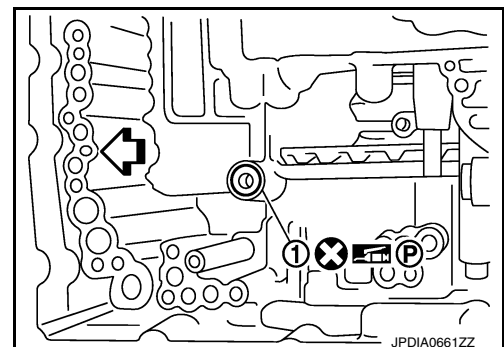

A
B
C
TM
E
F
G
H
I
J
K
L
M
N
O
P

CONTROL VALVE

< REMOVAL AND INSTALLATION >

[CVT: RE0F10H]

INSTALLATION

1. Install the lip seal (1) to the transaxle case.

CAUTION:

Do not reuse lip seal.

⇐ : Front

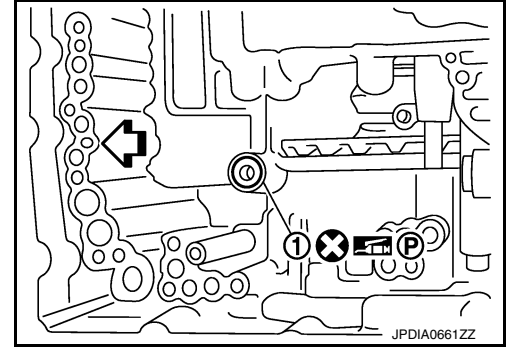

2. Install terminal cord assembly (1) to the transaxle case.

CAUTION:

Connect the CVT unit connector with the stopper facing up, and then press in until it clicks.

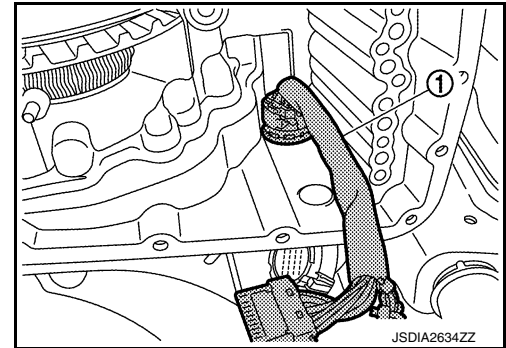

3. Install the control valve to the transaxle case.

CAUTION:

- Do not pinch the harness between the control valve and the transaxle case.
- Do not drop the control valve, ratio control valve and manual shaft.

4. Secure the control valve using the control valve bolts (A) and (B).

⇐ : Front

Bolt	Bolt length (mm)	Number of bolts
A	54	8
B	44	1

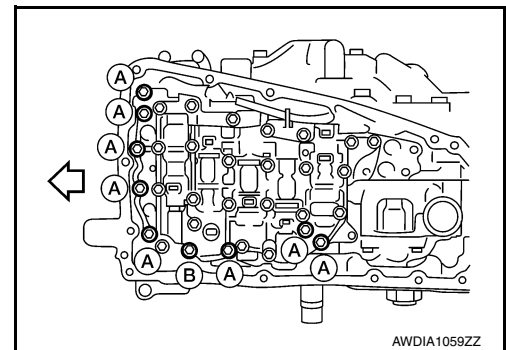

5. Connect the control valve harness connectors (A).

⇐ : Front

CAUTION:

- Do not pinch the harness between the control valve and the transaxle case.
- Securely insert the harness connector until it clicks and locks.

6. Install CVT fluid temperature sensor bracket (1).

← : Bolt

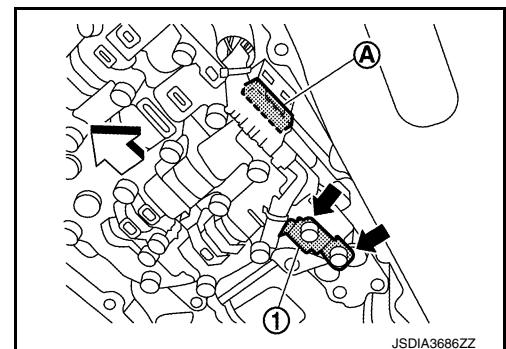

CONTROL VALVE

< REMOVAL AND INSTALLATION >

[CVT: RE0F10H]

7. Install the bracket (1).

← : Bolt
 ⇐ : Front

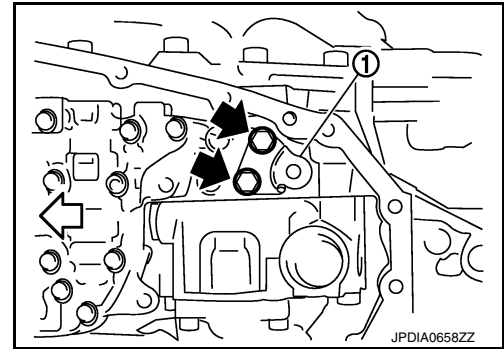

8. Install O-ring to oil strainer assembly.

CAUTION:

- Do not reuse O-ring.
- Apply CVT fluid NS-3 to O-ring.

9. Install the oil strainer assembly (1) using the oil strainer assembly bolts (A) and (B).

⇐ : Front

Bolt	Bolt length (mm)	Number of bolts
A	12	2
B	44	1

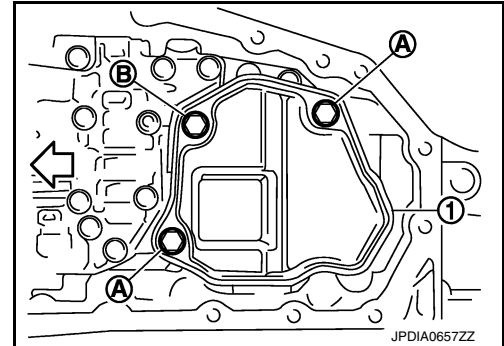

NOTE:

Remove the bracket and adjust the position again if the bolt hole positions are not aligned.

10. Install the manual plate (1) while aligning with the groove (A) of the manual valve.

CAUTION:

Assemble the manual plate while aligning its end with the cutout (⇐) of the manual valve.

(A) : Manual shaft
 ⇐ : Front

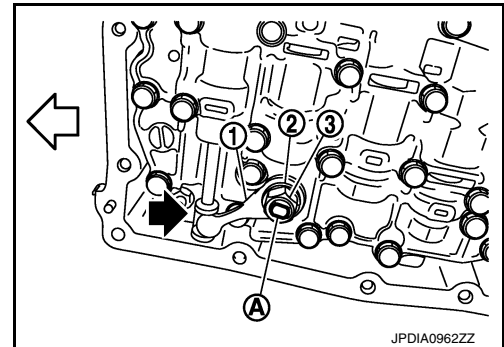

11. Install the spring washer (2) and the lock-nut (3), and then tighten to the specified torque.

12. Install the snap ring (1) to the CVT unit harness connector (A).

13. Connect the CVT unit harness connector.

14. install fender protector side cover (LH).

15. Install the magnet while aligning it with the convex side of oil pan.

CAUTION:

Completely clean the iron powder from the magnet area of oil pan and the magnet.

16. Install the oil pan to the transaxle case with the following procedure.

1. Install the oil pan gasket to the oil pan.

CAUTION:

- Completely wipe out any moisture, oil, and old gasket from the oil pan gasket surface and bolt hole of oil pan and transaxle case.
- Do not reuse oil pan gasket.

2. Install the oil pan assembly to the transaxle case, and then temporarily tighten the oil pan bolt.

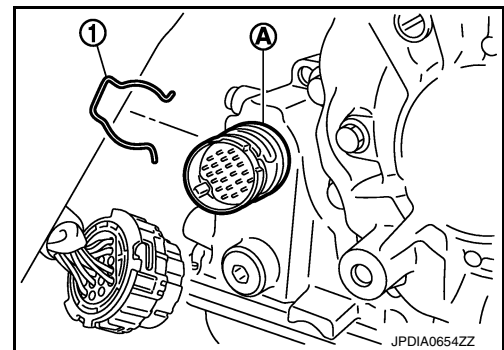

A
B
C
TM
E
F
G
H
I
J
K
L
M
N
O
P

CONTROL VALVE

[CVT: RE0F10H]

< REMOVAL AND INSTALLATION >

3. Tighten the oil pan bolts in the order shown to the specified torque.

← : Front

4. Tighten the oil pan bolts again clockwise from (1) shown to the specified torque.
17. Install drain plug gasket to drain plug.

CAUTION:

Do not reuse drain plug gasket.

18. Install drain plug to oil pan.
19. Install engine under cover. Refer to [EXT-26, "Exploded View"](#).
20. Connect battery negative terminal. Refer to [PG-101, "Removal and Installation \(Battery\)"](#).
21. Fill with CVT fluid to transaxle assembly. Refer to [TM-184, "Inspection"](#).

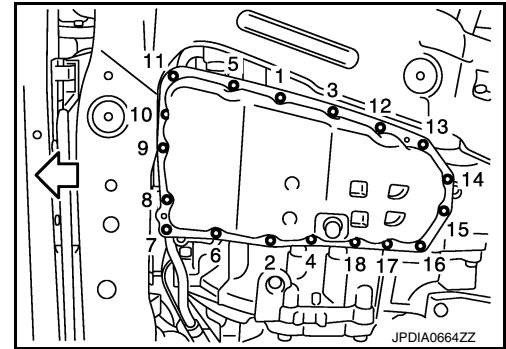

Inspection and Adjustment

INFOID:0000000011973030

INSPECTION AFTER REMOVAL

Check oil pan for foreign material.

- If a large amount of worn material is found, clutch plate may be worn.
 - If iron powder is found, bearings, gears, or clutch plates may be worn.
 - If aluminum powder is found, bushing may be worn, or chips or burrs of aluminum casting parts may enter.
- Check points where wear is found in all cases.

INSPECTION AFTER INSTALLATION

Check the CVT fluid level and leakage. Refer to [TM-184, "Inspection"](#).

ADJUSTMENT AFTER INSTALLATION

Perform "ADDITIONAL SERVICE WHEN REPLACING TRANSAXLE ASSEMBLY OR CONTROL VALVE ASSEMBLY". Refer to [TM-77, "Description"](#).

INPUT SPEED SENSOR

< REMOVAL AND INSTALLATION >

[CVT: RE0F10H]

INPUT SPEED SENSOR

Exploded View

INFOID:0000000011973031

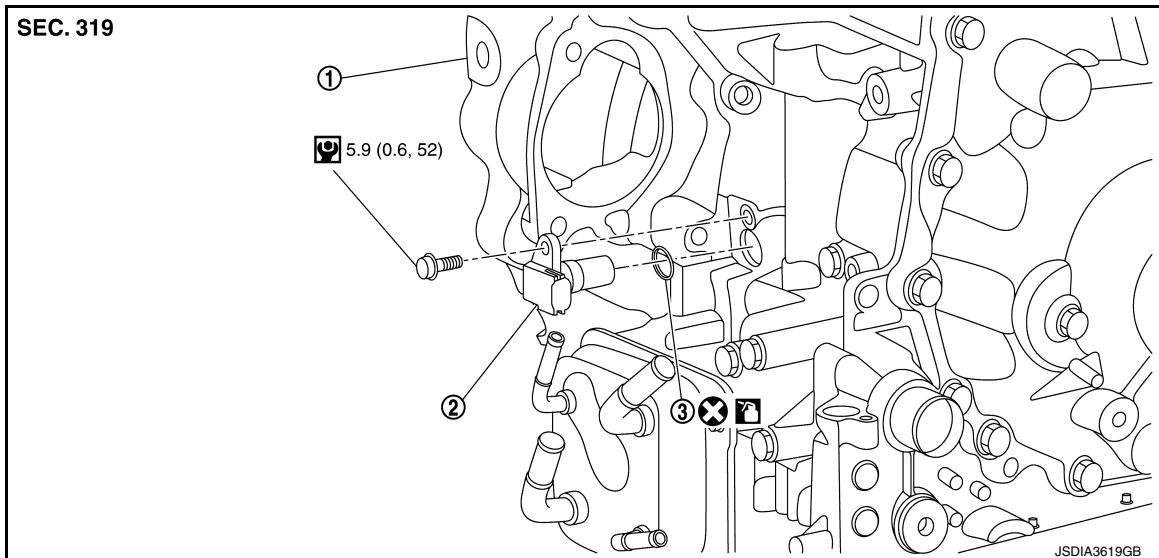

1. Transaxle assembly

2. Input speed sensor

3. O-ring

Removal and Installation

INFOID:0000000011973032

REMOVAL

1. Remove the battery tray and bracket. Refer to [PG-103, "Removal and Installation \(Battery Tray\)"](#).
2. Remove the starter motor. Refer to [STR-19, "Removal and Installation"](#).
3. Disconnect the harness connector from the input speed sensor (1).
4. Remove the input speed sensor bolt, then the input speed sensor (1).
5. Remove the O-ring (2) from the input speed sensor (1).

CAUTION:

Do not reuse O-ring.

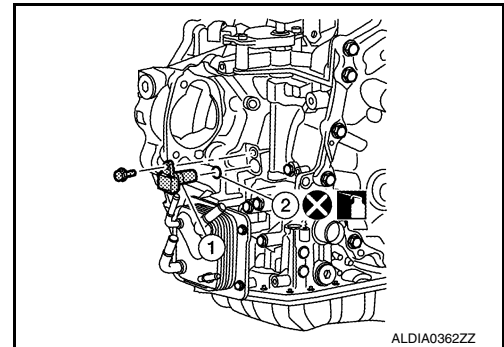

INSTALLATION

Installation is in the reverse order of removal.

CAUTION:

- Do not reuse O-ring.
- Apply Genuine NISSAN CVT Fluid NS-3 to the O-ring.
- Perform "ADDITIONAL SERVICE WHEN REPLACING ECM". Refer to [EC-156, "Description"](#)

Inspection and Adjustment

INFOID:0000000011973033

INSPECTION AFTER INSTALLATION

Check for CVT fluid leakage. Refer to [TM-184, "Inspection"](#).

ADJUSTMENT AFTER INSTALLATION

Adjust the CVT fluid level. Refer to [TM-82, "Adjustment"](#).

PRIMARY SPEED SENSOR

< REMOVAL AND INSTALLATION >

[CVT: RE0F10H]

PRIMARY SPEED SENSOR

Exploded View

INFOID:000000011973034

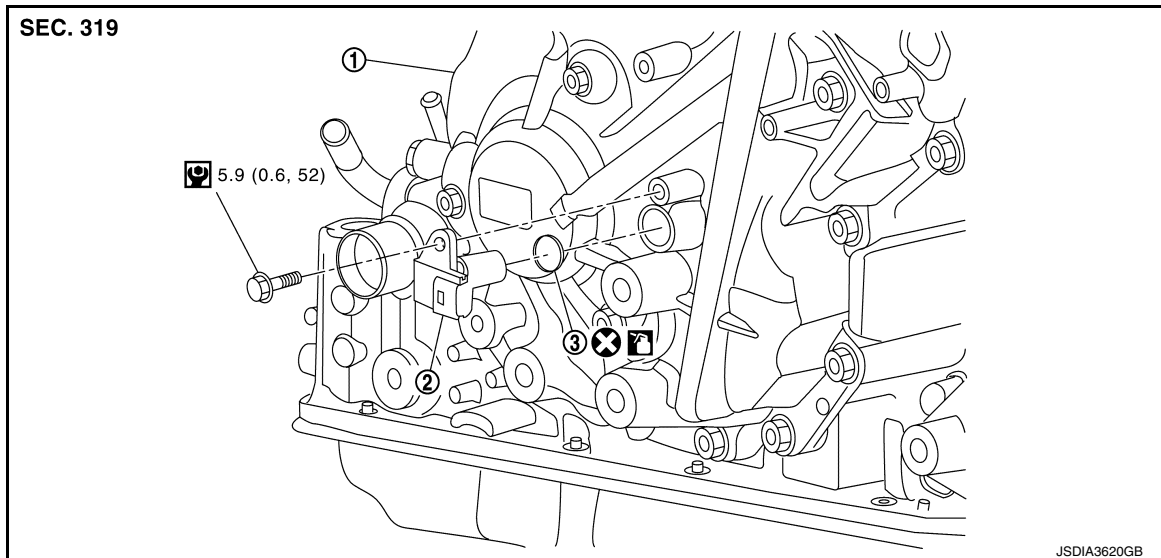

1. Transaxle assembly

2. Primary speed sensor

3. O-ring

Removal and Installation

INFOID:000000011973035

REMOVAL

1. Remove the fender protector side cover (LH). Refer to [EXT-28. "Removal and Installation"](#).
2. Disconnect the harness connector from primary speed sensor (1).
3. Remove the primary speed sensor bolt, then the primary speed sensor (1).
4. Remove the O-ring (2) from the primary speed sensor (1).

CAUTION:

Do not reuse O-ring.

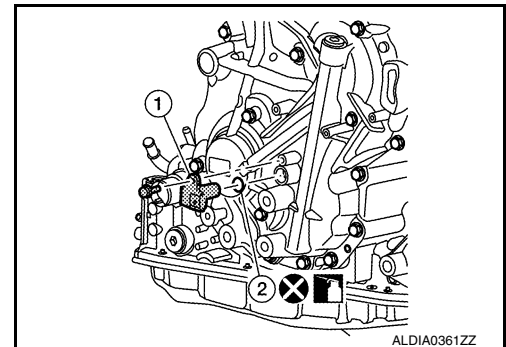

INSTALLATION

Installation is in the reverse order of removal.

CAUTION:

- Do not reuse O-ring.
- Apply Genuine NISSAN CVT Fluid NS-3 to the O-ring.

Inspection and Adjustment

INFOID:000000011973036

INSPECTION AFTER INSTALLATION

Check for CVT fluid leakage. Refer to [TM-184. "Inspection"](#).

ADJUSTMENT AFTER INSTALLATION

Adjust the CVT fluid level. Refer to [TM-82. "Adjustment"](#).

OUTPUT SPEED SENSOR

< REMOVAL AND INSTALLATION >

[CVT: RE0F10H]

OUTPUT SPEED SENSOR

Exploded View

INFOID:000000011973037

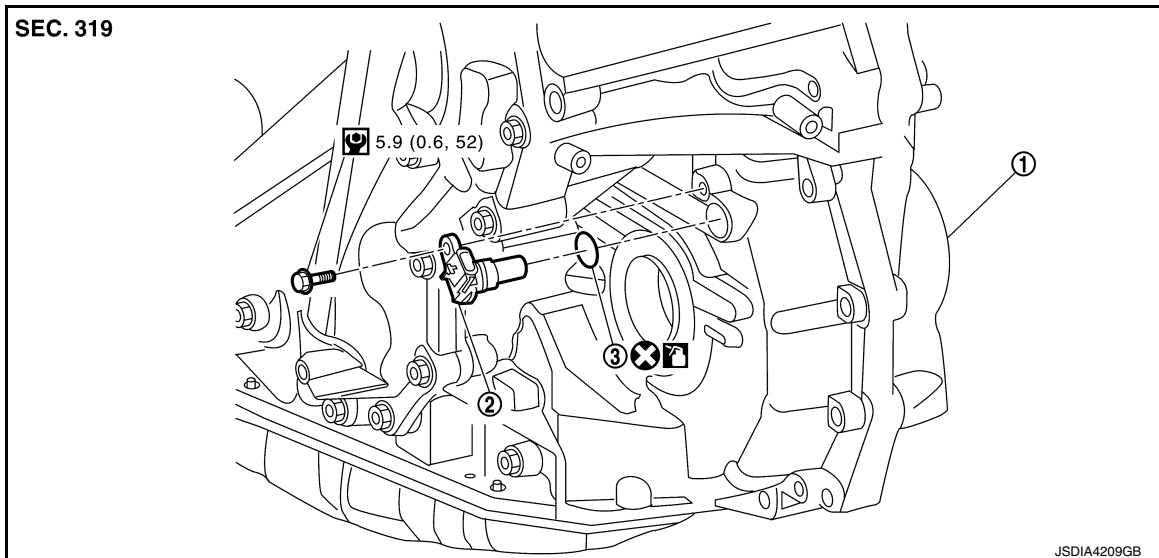

1. Transaxle assembly

2. Output speed sensor

3. O-ring

Removal and Installation

INFOID:000000011973038

REMOVAL

1. Disconnect the harness connector from output speed sensor (1).
2. Remove the output speed sensor bolt, then the output speed sensor (1).
3. Remove the O-ring (2) from the output speed sensor (1).

CAUTION:

Do not reuse O-ring.

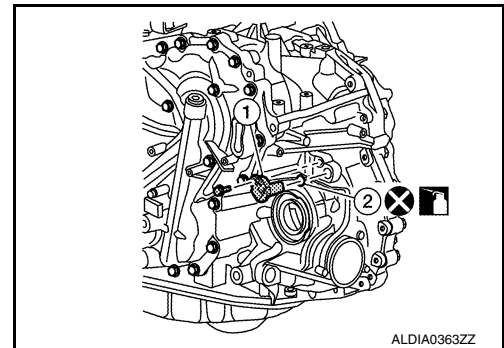

INSTALLATION

Installation is in the reverse order of removal.

CAUTION:

- Do not reuse O-ring.
- Apply Genuine NISSAN CVT Fluid NS-3 to the O-ring.

Inspection and Adjustment

INFOID:000000011973039

INSPECTION AFTER INSTALLATION

Check for CVT fluid leakage. Refer to [TM-184, "Inspection"](#).

ADJUSTMENT AFTER INSTALLATION

Adjust the CVT fluid level. Refer to [TM-82, "Adjustment"](#).

DIFFERENTIAL SIDE OIL SEAL

< REMOVAL AND INSTALLATION >

[CVT: RE0F10H]

DIFFERENTIAL SIDE OIL SEAL

Exploded View

INFOID:000000011973040

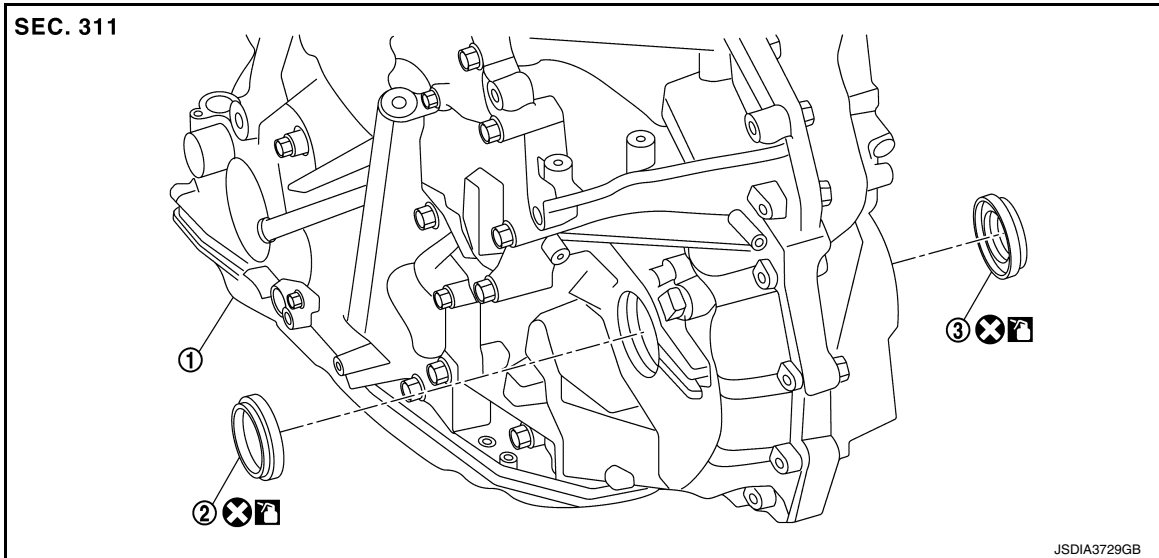

1. Transaxle assembly 2. Differential side oil seal (left side) 3. Differential side oil seal (right side)

Removal and Installation

INFOID:000000011973041

REMOVAL

NOTE:

When removing components such as hoses, tubes/lines, etc., cap or plug openings to prevent fluid from spilling.

1. Remove front drive shaft. Refer to [FAX-18. "Removal and Installation \(LH\)"](#) (LH) or [FAX-20. "Removal and Installation \(RH\)"](#) (RH).
2. Remove differential oil side seal (1) using suitable tool (A).

CAUTION:

Be careful not to scratch transaxle case and converter housing.

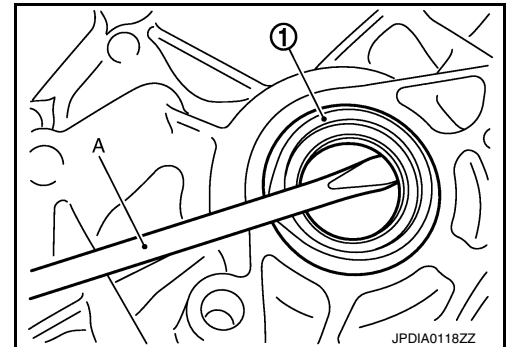

INSTALLATION

Installation is in the reverse order of removal.

1. Measure height (A) of seal lip. Calculate protrusion (C) of oil seal lip according to measured height (A) of seal lip and reference value (B) of side oil insertion.

- (1) : Differential side oil seal
 (2) : Converter housing or transaxle case

Lip protrusion (C) : C=A-B

Differential side oil seal insertion reference value (B) : 0 mm (0 in)

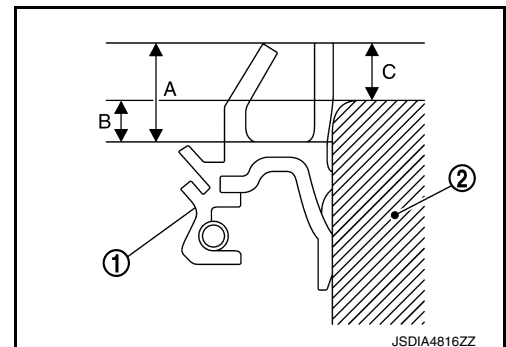

DIFFERENTIAL SIDE OIL SEAL

< REMOVAL AND INSTALLATION >

[CVT: RE0F10H]

CAUTION:

- Do not reuse differential side oil seal.
- Put a mark on the measurement area and measure height of seal lip at four points diagonally using suitable tool.

NOTICE:

Since seal lips have a tolerance of ± 0.3 mm (± 0.012 in) at maximum due to manufacturing tolerances or packing conditions, it is necessary to measure the seal lip height beforehand to clarify the tolerance.

2. As an indicator of the parallelism and insertion depth, cut a masking tape (1) to specified width [add 1 mm (0.04 in) to the value calculated from the tip of differential side oil seal lip] and affix to the differential side oil seal.
3. Install the differential side oil seal using a Tool (transaxle case side), and using suitable tool (converter housing side), according to the guide of the masking tape (1).

Tool number : KV31103700

CAUTION:

- If differential side oil seal is inserted deeper than the reference value, use a new differential side oil seal and perform the steps again.
- Apply CVT fluid to the differential side oil seal lip and around the oil seal.

4. Remove masking tape.
5. Adjust as instructed below to optimize the protrusion size and parallelism.

CAUTION:

If differential side oil seal is inserted deeper than the reference value, use a new differential side oil seal and perform the steps again.

- Protrusion size (A)

CAUTION:

Protrusion must fall within ± 0.5 mm (0.020 in) of calculated size.

- Parallelism at four diagonal points (➡)

CAUTION:

The difference among four diagonal points must be within 0.3 mm (0.012 in).

NOTE:

If differential side oil seal is uneven while installing, tilt suitable tool.

6. Check that the protrusion size and parallelism are adequate.

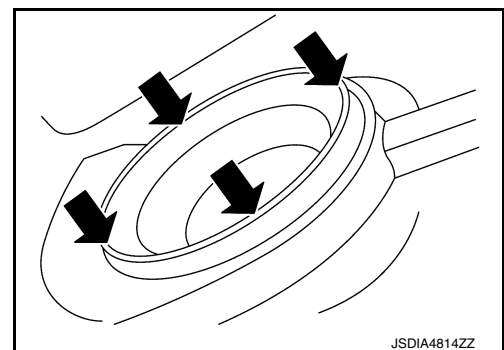
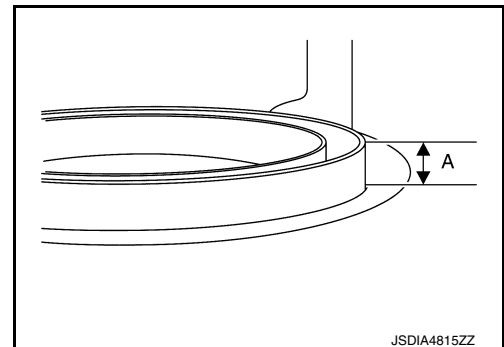
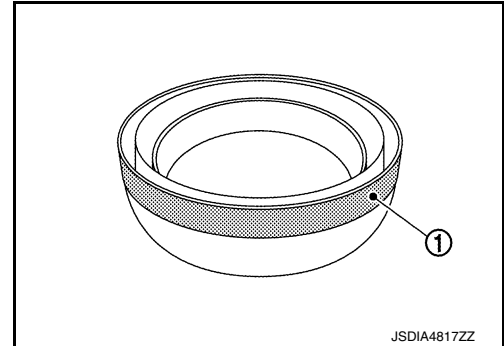

INFOID:000000011973042

Inspection and Adjustment

INSPECTION AFTER INSTALLATION

Check for CVT fluid leakage. Refer to [TM-184, "Inspection"](#).

ADJUSTMENT AFTER INSTALLATION

Adjust the CVT fluid level. Refer to [TM-82, "Adjustment"](#).

CVT OIL WARMER SYSTEM

< REMOVAL AND INSTALLATION >

[CVT: RE0F10H]

CVT OIL WARMER SYSTEM WATER HOSE

WATER HOSE : Exploded View

INFOID:000000011973043

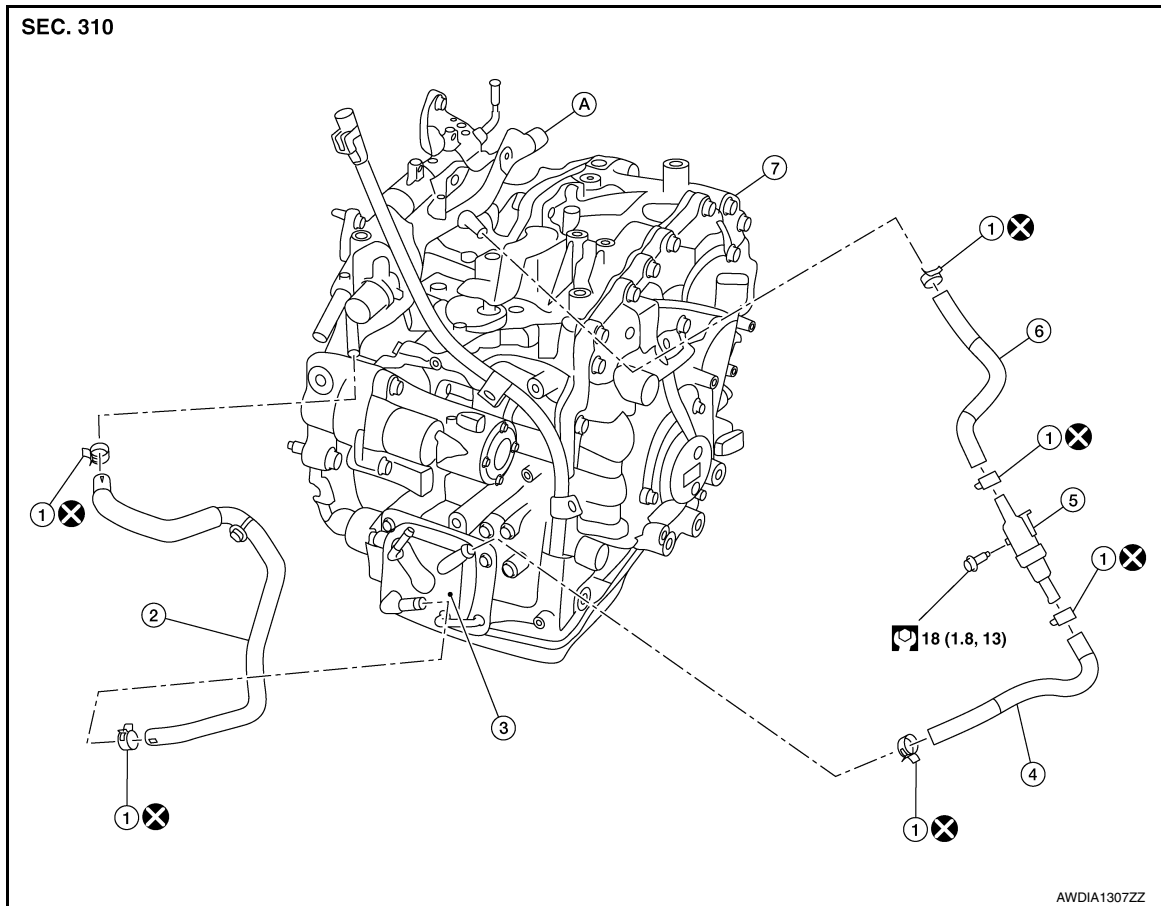

- | | | |
|-----------------------|----------------------|---------------------|
| 1. Hose clamp | 2. CVT water hose A | 3. CVT oil warmer |
| 4. CVT water hose B | 5. Heater thermostat | 6. CVT water hose C |
| 7. Transaxle assembly | | |
| A. Water outlet | | |

WATER HOSE : Removal and Installation

INFOID:000000011973044

REMOVAL

WARNING:

Do not remove the radiator cap when the engine is hot. Serious burns could occur from high pressure coolant escaping from the radiator. Wrap a thick cloth around the cap. Slowly turn it a quarter turn to allow built-up pressure to escape. Carefully remove the cap by turning it all the way.

CAUTION:

Perform when the engine is cold.

NOTE:

When removing components such as hoses, tubes/lines, etc., cap or plug openings to prevent fluid from spilling.

1. Remove front under cover. Refer to [EXT-26. "Removal and Installation"](#).
2. Remove engine room cover. Refer to [EM-25. "Removal and Installation"](#).
3. Remove front air duct and air cleaner case assembly. Refer to [EM-26. "Removal and Installation"](#).

CVT OIL WARMER SYSTEM

[CVT: RE0F10H]

< REMOVAL AND INSTALLATION >

- Release clip (A) and release hose clamps and remove CVT water hose A from water outlet.

CAUTION:

Do not reuse hose clamps.

← : Front

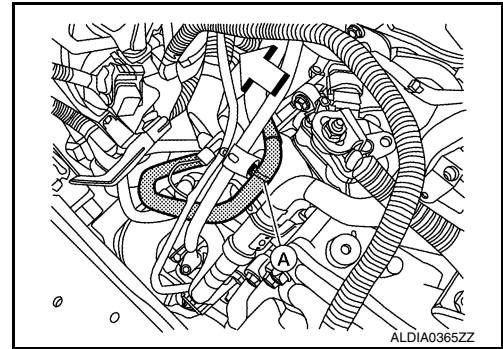

- Remove CVT heater thermostat bolt, release hose clamps then remove CVT heater thermostat and CVT water hose C from water outlet.

CAUTION:

Do not reuse hose clamps.

- Remove CVT water hose inlet and CVT water hose outlet from CVT oil warmer.

INSTALLATION

Note the following, and install in the reverse order of removal.

CAUTION:

Do not reuse hose clamps.

- Insert CVT water hose according to dimension (A) described below.

CVT water hose (1)	Insert side tube (2)	Dimension (A)
CVT water hose A	Water outlet	End reaches the spool portion (B)
	CVT oil warmer	
CVT water hose B	CVT oil warmer	
	Heater thermostat	
CVT water hose C	Heater thermostat	
	Water outlet	

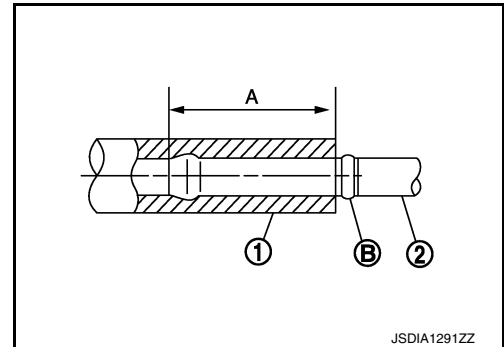

- Install hose clamps (1) at the both ends of CVT water hose (2) with dimension (A) from the hose end.

Dimension (A) : 5 – 7 mm (0.20 – 0.28 in)

- Hose clamp should not interfere with the bulge.

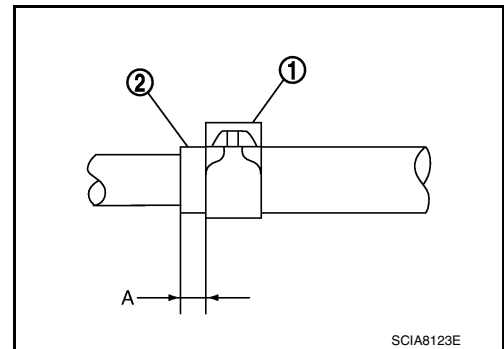

CVT water hose	Hose end	Paint mark	Position of hose clamp
CVT water hose A	Water outlet side	Facing Upward	A
	CVT oil warmer side	Facing to the front of the vehicle	C
CVT water hose B	CVT oil warmer side	Facing to the front of the vehicle	B
	Heater thermostat side	N/A	A
CVT water hose C	Heater thermostat side	N/A	A
	Water outlet side	Facing upward	C

*: Refer to the illustrations for the specific position of each hose clamp tab.

CVT OIL WARMER SYSTEM

[CVT: RE0F10H]

< REMOVAL AND INSTALLATION >

- The illustrations indicate the view from the hose ends.
- When installing hose clamps the center line of each clamp tab should be positioned as shown.

- A. : Marking is on front
- B. : Marking is on front
- C. : Marking is on top

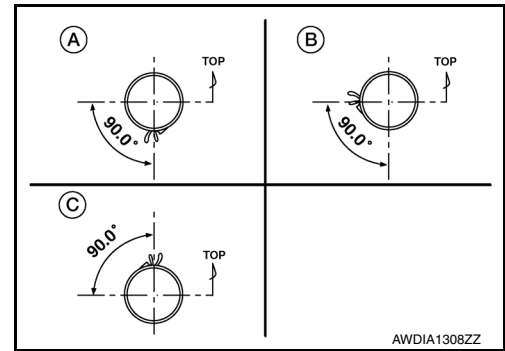

AWDIA1308ZZ

WATER HOSE : Inspection

INFOID:000000011973045

INSPECTION AFTER INSTALLATION

Start and warm up the engine. Visually check that there is no leakage of engine coolant and CVT fluid.

CVT FLUID COOLER HOSE

CVT FLUID COOLER HOSE : Exploded View

INFOID:000000011973046

COMPONENT PARTS LOCATION

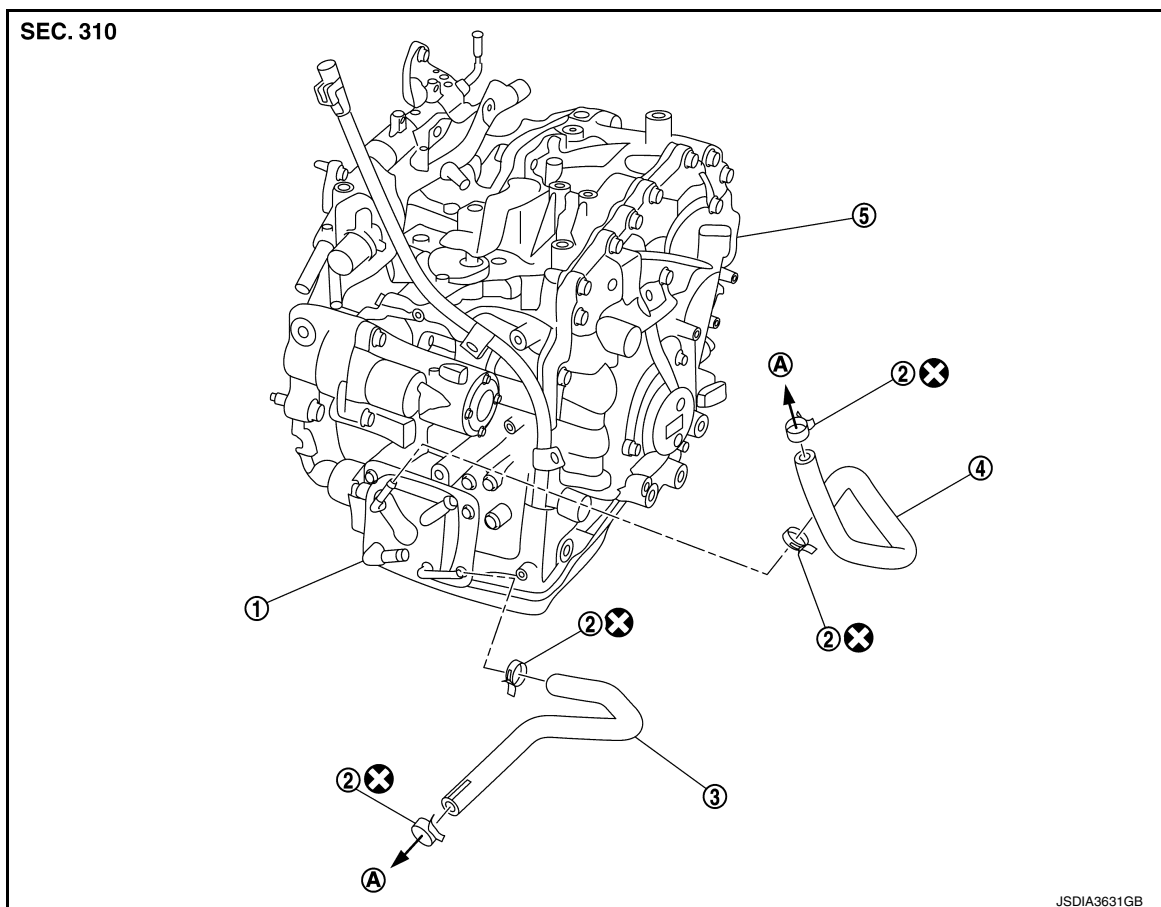

- | | | |
|----------------------------|-----------------------|----------------------------|
| 1. CVT oil warmer | 2. Hose clamp | 3. CVT fluid cooler hose A |
| 4. CVT fluid cooler hose B | 5. Transaxle assembly | |
| A. : To radiator | | |

CVT FLUID COOLER HOSE : Removal and Installation

INFOID:000000011973047

REMOVAL

CVT OIL WARMER SYSTEM

[CVT: RE0F10H]

< REMOVAL AND INSTALLATION >

NOTE:

When removing components such as hoses, tubes/lines, etc., cap or plug openings to prevent fluid from spilling.

1. Remove front under cover. Refer to [EXT-26, "Removal and Installation"](#).
2. Remove engine room cover. Refer to [EM-25, "Removal and Installation"](#).
3. Remove the front air duct and air cleaner case assembly. Refer to [EM-26, "Removal and Installation"](#).
4. Release hose clamp, then remove CVT fluid cooler hose A and B from CVT oil warmer and radiator.

CAUTION:

Do not reuse hose clamps.

INSTALLATION

Installation is in the reverse order of removal.

CAUTION:

Do not reuse hose clamps.

- Insert CVT fluid cooler hoses according to dimension (A).

CVT fluid cooler hose (1)	Insert side tube (2)	Dimension (A)
CVT fluid cooler hose A	Radiator tube	End reaches the 2-stage bulge (B)
	CVT oil warmer	
CVT fluid cooler hose B	CVT oil warmer	
	Radiator tube	

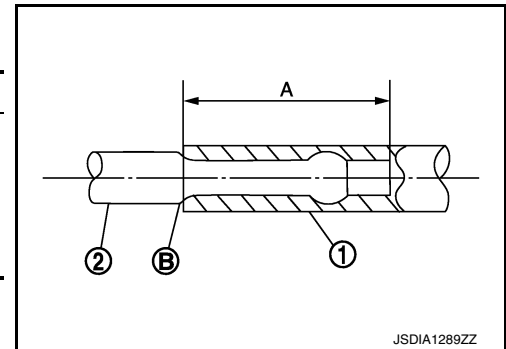

- Install hose clamps (1) at both ends of CVT fluid cooler hoses (2) with dimension (A) from the hose end.

Dimension (A) : 5 – 7 mm (0.20 – 0.28 in)

- Hose clamp should not interfere with the bulge.

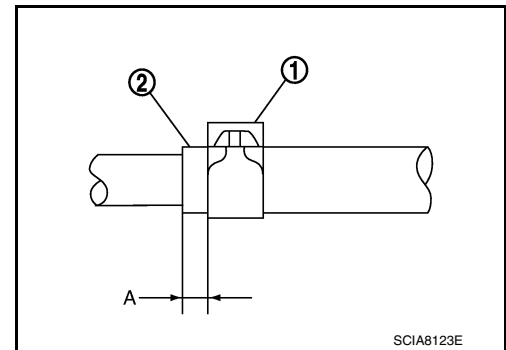

CVT fluid cooler hose	Hose end	Paint mark	Position of hose clamp
CVT fluid cooler hose A	Radiator tube side	Facing upward	B
	CVT oil warmer side	Facing to the right of the vehicle	B
CVT fluid cooler hose B	CVT oil warmer side	Facing downward	A
	Radiator tube side	Facing to the front of the vehicle	B

*: Refer to the illustrations for the specific position of each hose clamp tab.

- The illustrations indicate the view from the hose ends.
- When installing hose clamps the center line of each clamp tab should be positioned as shown.

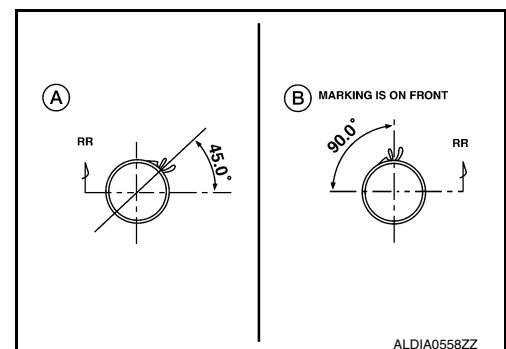

CVT OIL WARMER SYSTEM

< REMOVAL AND INSTALLATION >

[CVT: RE0F10H]

CVT FLUID COOLER HOSE : Inspection

INFOID:000000011973048

INSPECTION AFTER INSTALLATION

Check for CVT fluid leakage and check CVT fluid level. Refer to [TM-184. "Inspection"](#).

CVT OIL WARMER

CVT OIL WARMER : Exploded View

INFOID:000000011973049

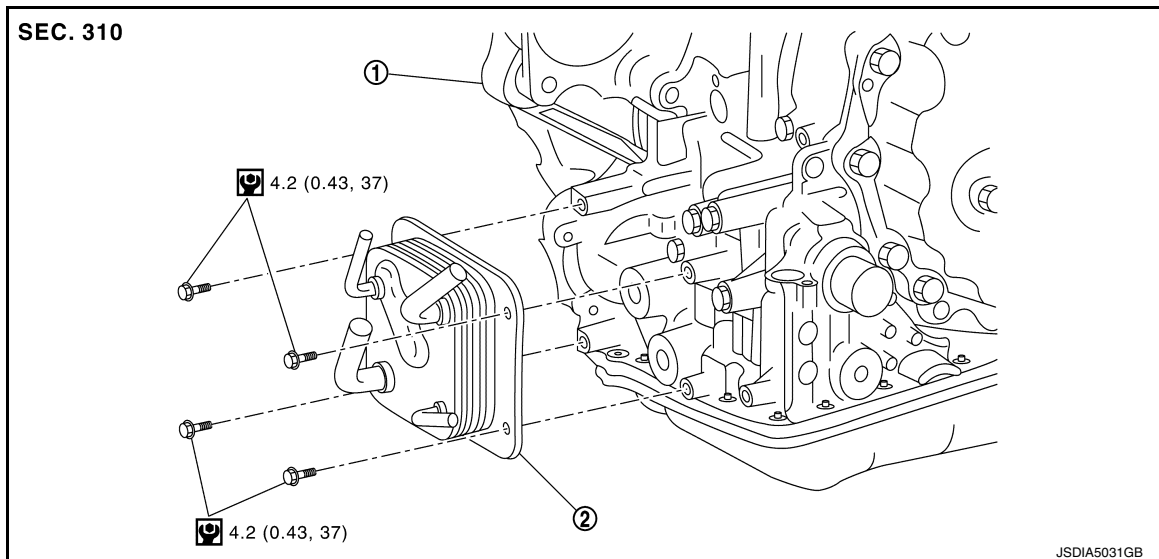

1. Transaxle assembly

2. CVT oil warmer

CVT OIL WARMER : Removal and Installation

INFOID:000000011973050

REMOVAL

WARNING:

Do not remove the radiator cap when the engine is hot. Serious burns could occur from high pressure coolant escaping from the radiator. Wrap a thick cloth around the cap. Slowly turn it a quarter turn to allow built-up pressure to escape. Carefully remove the cap by turning it all the way.

CAUTION:

Perform when the engine is cold.

1. Remove front under cover. Refer to [EXT-26. "Removal and Installation"](#).
2. Remove CVT water hose inlet and CVT water hose outlet from CVT oil warmer. Refer to [TM-206. "WATER HOSE : Exploded View"](#).
3. Remove CVT fluid cooler hose inlet and CVT fluid cooler hose outlet from CVT oil warmer. Refer to [TM-208. "CVT FLUID COOLER HOSE : Exploded View"](#).
4. Remove CVT oil warmer bolts, then remove CVT oil warmer from vehicle.

INSTALLATION

Installation is in the reverse order of removal.

CVT OIL WARMER : Inspection

INFOID:000000011973051

INSPECTION AFTER INSTALLATION

- Check for CVT fluid leakage and check CVT fluid level. Refer to [TM-184. "Inspection"](#).
- Start and warm up the engine. Visually check that there is no leakage of engine coolant and CVT fluid.

PLUG

< REMOVAL AND INSTALLATION >

[CVT: RE0F10H]

PLUG

Description

INFOID:0000000011973052

Replace the O-ring if oil leakage or exudes from the plug.

Exploded View

INFOID:0000000011973053

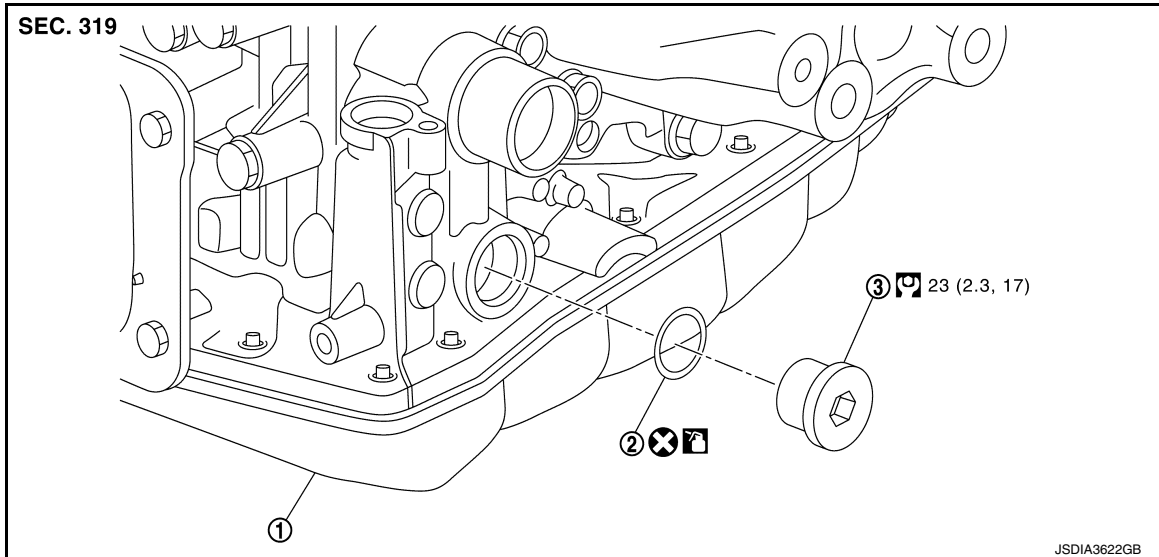

1. Transaxle assembly

2. O-ring

3. Plug

Removal and Installation

INFOID:0000000011973054

REMOVAL

1. Remove fender protector side cover (LH). Refer to [EXT-28, "Removal and Installation"](#).
2. Remove the plug and O-ring.

INSTALLATION

Installation is in the reverse order of removal.

CAUTION:

- Do not reuse O-ring.
- Apply Genuine NISSAN CVT Fluid NS-3 to O-ring.

Inspection and Adjustment

INFOID:0000000011973055

INSPECTION AFTER INSTALLATION

Check for CVT fluid leakage. Refer to [TM-184, "Inspection"](#).

ADJUSTMENT AFTER INSTALLATION

Adjust the CVT fluid level. Refer to [TM-82, "Adjustment"](#).

TRANSAXLE ASSEMBLY

< UNIT REMOVAL AND INSTALLATION >

[CVT: RE0F10H]

UNIT REMOVAL AND INSTALLATION

TRANSAXLE ASSEMBLY

Exploded View

INFOID:0000000011973056

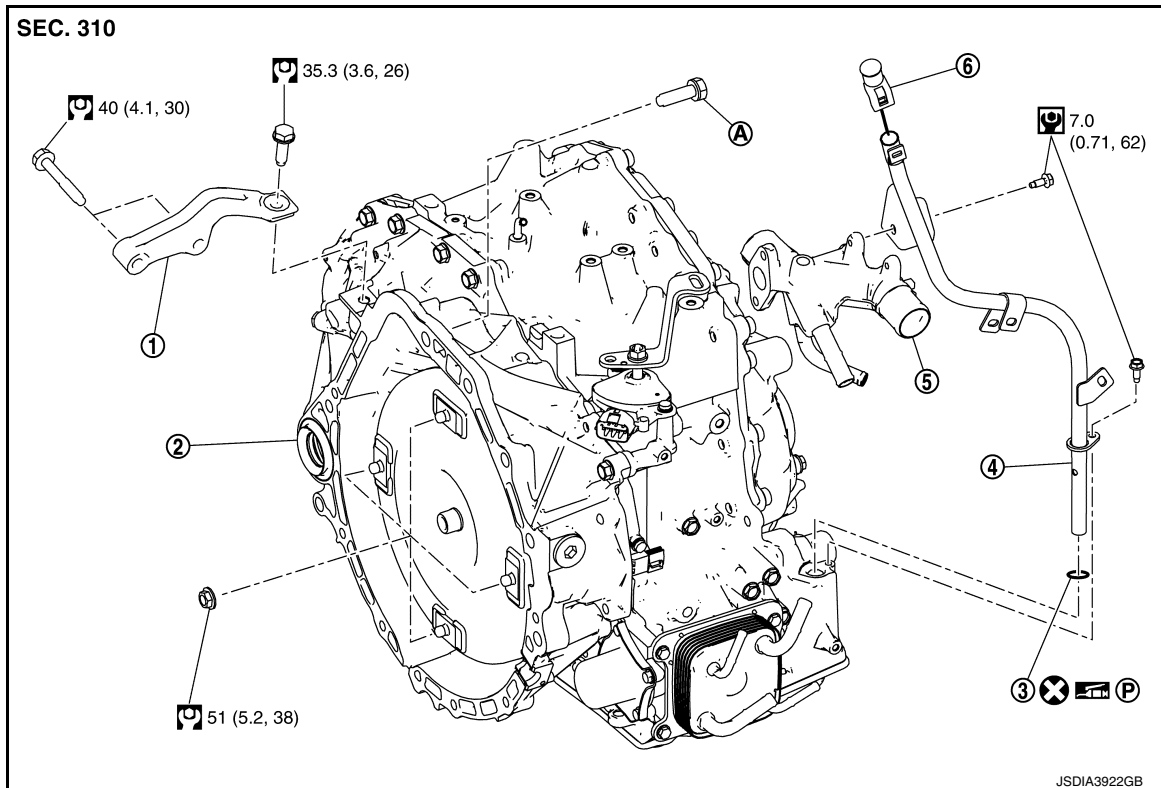

- | | | |
|-----------------------------|-----------------------|--------------------------------|
| 1. Gusset | 2. Transaxle assembly | 3. O-ring |
| 4. CVT fluid charging pipe | 5. Water outlet | 6. CVT fluid charging pipe cap |
| A. : Refer to INSTALLATION. | | |

Removal and Installation

INFOID:0000000011973057

REMOVAL

WARNING:

Do not remove the radiator cap when the engine is hot. Serious burns could occur from high pressure coolant escaping from the radiator. Wrap a thick cloth around the cap. Slowly turn it a quarter turn to allow built-up pressure to escape. Carefully remove the cap by turning it all the way.

CAUTION:

- Perform when the engine is cold.
- When replacing the transaxle, perform "ADDITIONAL SERVICE WHEN REPLACING TRANSAXLE ASSEMBLY". Refer to [TM-77, "Description"](#).
- When replacing TCM and transaxle assembly simultaneously, perform "ADDITIONAL SERVICE WHEN REPLACING TCM AND TRANSAXLE ASSEMBLY". Refer to [TM-79, "Description"](#).

NOTE:

When removing components such as hoses, tubes/lines, etc., cap or plug openings to prevent fluid from spilling.

1. Remove the engine and transaxle with the front suspension member as a unit. Refer to [EM-107, "Removal and Installation"](#).
2. Disconnect the transaxle harness connectors.
3. Disconnect the CVT oil warmer water hoses from engine side. Refer to [TM-206, "WATER HOSE : Removal and Installation"](#).

TRANSAXLE ASSEMBLY

[CVT: RE0F10H]

< UNIT REMOVAL AND INSTALLATION >

4. Remove the CVT fluid charging pipe.
5. Remove the transaxle to engine and engine to transaxle bolts.
6. Separate the engine from the transaxle and remove the engine from the front suspension member. Refer to [EM-107. "Removal and Installation"](#).

NOTE:

Using paint, put matching marks on the drive plate and torque converter when removing the torque converter to drive plate nuts.

7. Remove transmission bracket.
8. Lift the transaxle from the front suspension member.

INSTALLATION

Installation is in the reverse order of removal.

NOTE:

Write down the serial number of the new transaxle assembly.

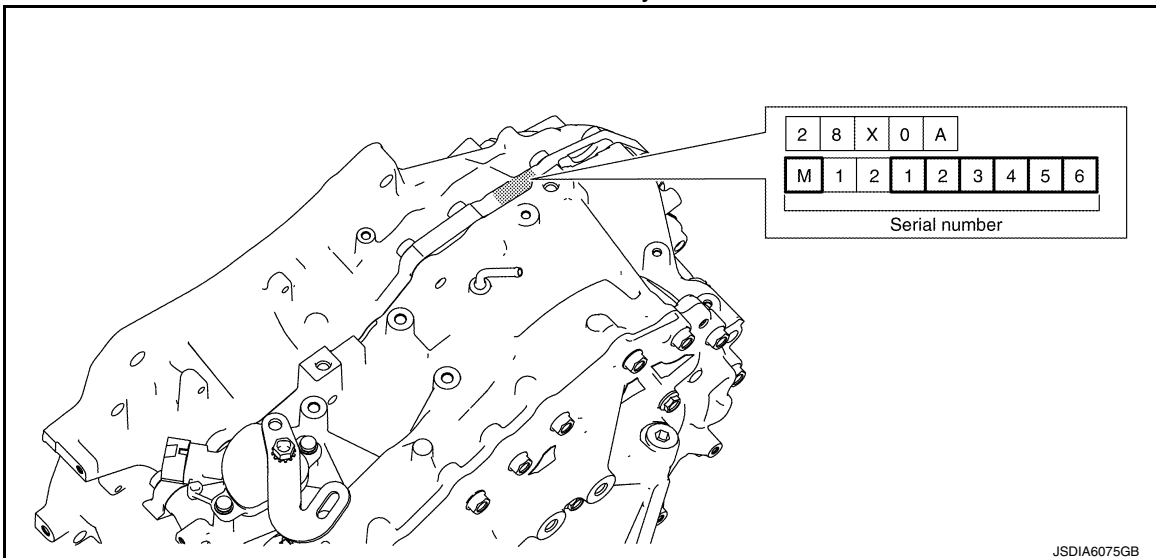

CAUTION:

- When replacing an engine or transaxle you must make sure any dowels are installed correctly during re-assembly
- Improper alignment caused by missing dowels may cause vibration, oil leaks or breakage of drive train components.
- Do not reuse O-rings or copper sealing washers.
- When turning crankshaft, turn it clockwise as viewed from the front of the engine.
- When tightening the nuts for the torque converter while securing the crankshaft pulley bolt, be sure to confirm the tightening torque of the crankshaft pulley bolt. Refer to [EM-58. "Removal and Installation"](#).
- After converter is installed to drive plate, rotate crankshaft several turns to check that CVT rotates freely without binding.
- When installing the CVT to the engine, align the matching mark on the drive plate with the matching mark on the torque converter.
- When installing CVT assembly to the engine assembly, attach the bolts in accordance with the following standard.

Bolt No.	1	2	3	4	5
Number of bolts	1	2	1	1	4
Bolt length "ℓ" mm (in)	55 (2.17)	39 (1.54)	35 (1.38)	50 (1.97)	45 (1.77)
Tightening torque N·m (kg·m, ft·lb)	74.5 (7.6, 55)				50.0 (5.1, 37)

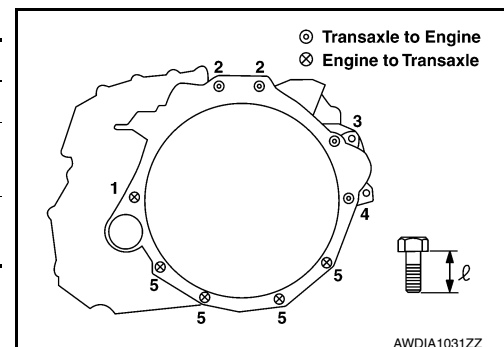

TRANSAXLE ASSEMBLY

< UNIT REMOVAL AND INSTALLATION >

[CVT: RE0F10H]

- When installing the drive plate to torque converter nuts, tighten them temporarily. then tighten the nuts to the specified torque.

Inspection and Adjustment

INFOID:000000011973058

INSPECTION BEFORE INSTALLATION

After inserting a torque converter to the CVT, check dimension (A) with in the reference value limit.

- B : Scale
- C : Straightedge

Dimension (A) : Refer to [TM-218, "Torque Converter"](#).

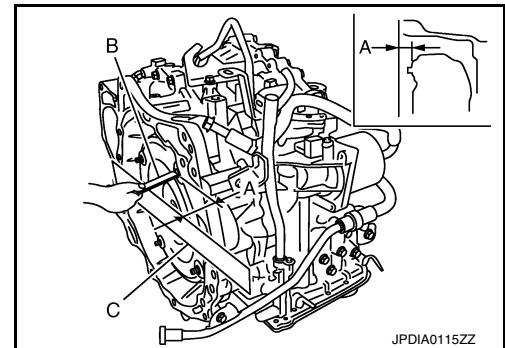

INSPECTION AFTER INSTALLATION

Check the following items:

- CVT fluid leakage, refer to [TM-184, "Inspection"](#).
- For CVT position, refer to [TM-85, "Inspection"](#).
- Start the engine and check for coolant leakage from the parts which are removed and reinstalled.

ADJUSTMENT AFTER INSTALLATION

- Adjust the CVT fluid level. Refer to [TM-82, "Adjustment"](#).
- Perform "ADDITIONAL SERVICE WHEN REPLACE TRANSAXLE ASSEMBLY". Refer to [TM-77, "Description"](#).

TORQUE CONVERTER AND CONVERTER HOUSING OIL SEAL

< UNIT DISASSEMBLY AND ASSEMBLY >

[CVT: RE0F10H]

UNIT DISASSEMBLY AND ASSEMBLY

TORQUE CONVERTER AND CONVERTER HOUSING OIL SEAL

Exploded View

INFOID:0000000011973059

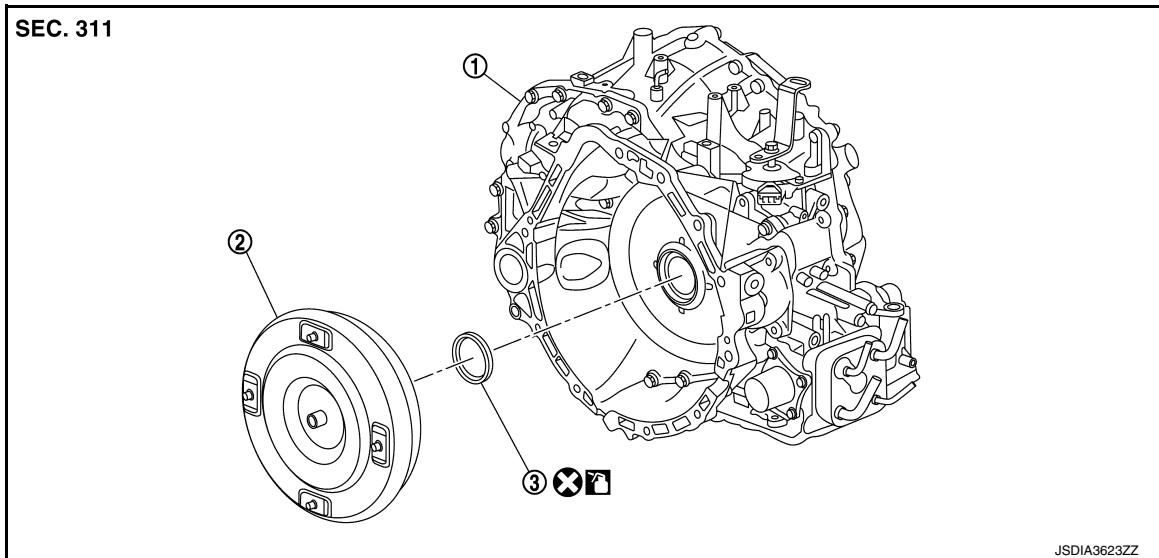

① Transaxle assembly

② Torque converter

③ Converter housing oil seal

⊗ : Always replace after every disassembly.

🖌️ : Apply CVT Fluid

Disassembly

INFOID:0000000011973060

1. Remove transaxle assembly. Refer to [TM-212. "Removal and Installation"](#).
2. Remove torque converter from transaxle assembly.
CAUTION:
Do not damage the bushing on the inside of torque converter sleeve when removing torque converter.
3. Remove converter housing oil seal using suitable tool.
CAUTION:
Be careful not to scratch converter housing.

Assembly

INFOID:0000000011973061

Assembly is in the reverse order of disassembly.

CAUTION:

Do not reuse converter housing oil seal.

NOTE:

Lubricate converter housing oil seal prior to installation.

TORQUE CONVERTER AND CONVERTER HOUSING OIL SEAL

< UNIT DISASSEMBLY AND ASSEMBLY >

[CVT: RE0F10H]

- Drive converter housing oil seal ① evenly using a drift (A) (commercial service tool) so that converter housing oil seal protrudes by the dimension (B) respectively.

Unit: mm (in)

Commercial service tool: (A)	Outer diameter: 65 (2.56)
	Inner diameter: 60 (2.36)

② : Transaxle assembly

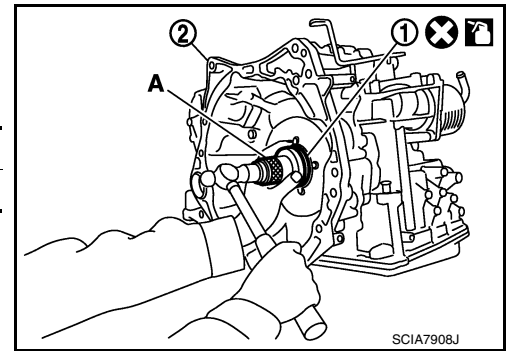

Unit: mm (in)

Dimension (B)	1.0 ± 0.5 (0.039 \pm 0.020)
---------------	-----------------------------------

NOTE:

Converter housing oil seal pulling direction is used as the reference.

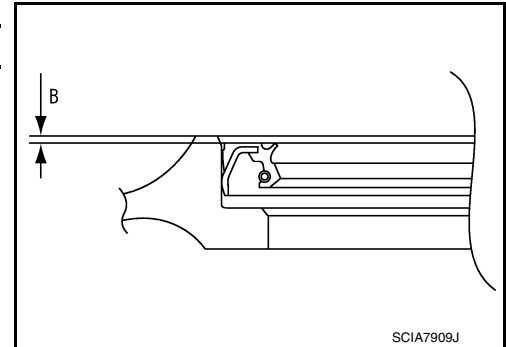

- Attach the pawl (A) of the torque converter to the drive sprocket hole (B) on the transaxle assembly side.

CAUTION:

- Rotate the torque converter for installing torque converter.
- Do not damage the bushing inside the torque converter sleeve when installing the converter housing oil seal.

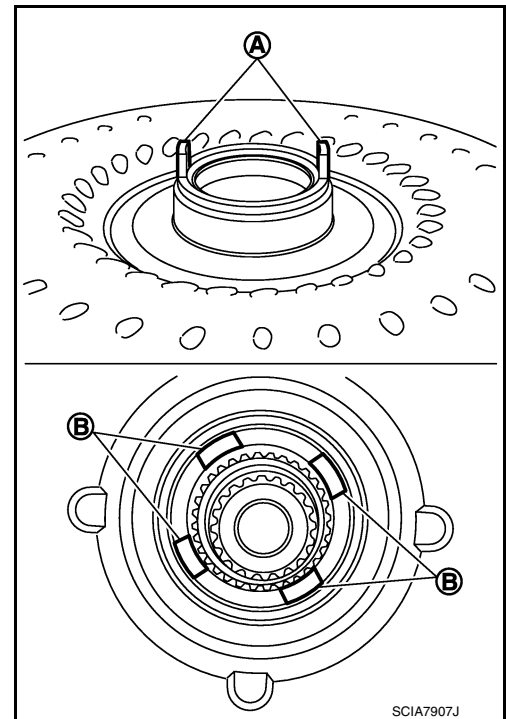

Inspection

INFOID:000000011973062

INSPECTION AFTER INSTALLATION

TORQUE CONVERTER AND CONVERTER HOUSING OIL SEAL

< UNIT DISASSEMBLY AND ASSEMBLY >

[CVT: RE0F10H]

- After inserting a torque converter to the CVT, check dimension (A) with in the reference value limit.

- B : Scale
- C : Straightedge

Dimension (A) : Refer to [TM-218, "Torque Converter"](#).

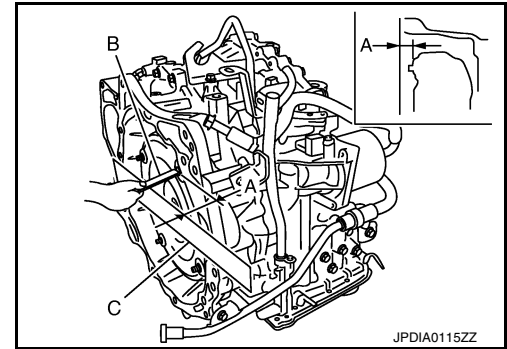

A
B
C

TM

E
F
G
H
I
J
K
L
M
N
O
P

SERVICE DATA AND SPECIFICATIONS (SDS)

< SERVICE DATA AND SPECIFICATIONS (SDS)

[CVT: RE0F10H]

SERVICE DATA AND SPECIFICATIONS (SDS)

SERVICE DATA AND SPECIFICATIONS (SDS)

General Specification

INFOID:0000000011973063

Applied model	Engine	VQ35DE
	Axle	2WD
Transaxle model		RE0F10H
Transaxle gear ratio	D position	2.413 – 0.383
	R position	1.798
	Final drive	5.250
Recommended fluid	Refer to MA-16. "FOR USA AND CANADA : Fluids and Lubricants" (for USA and Canada), MA-17. "FOR MEXICO : Fluids and Lubricants" (for Mexico).	
Fluid capacity liter (US qt, Imp qt)		

Shift Characteristics

INFOID:0000000011973064

Unit: rpm

Throttle position	Shift pattern	CVT input speed	
		At 40 km/h (25 MPH)	At 60 km/h (37 MPH)
2/8	"D" position (Normal mode)	1,300 – 2,200	1,400 – 2,200
	"D" position (SPORT mode)	1,300 – 2,200	1,400 – 2,200
8/8	"D" position (Normal mode)	2,500 – 3,600	3,000 – 4,200
	"D" position (SPORT mode)	2,500 – 3,700	3,000 – 5,100

NOTE:

Lock-up is engaged at the vehicle speed of approximately 18 km/h (12 MPH) to 40 km/h (24 MPH).

Stall Speed

INFOID:0000000011973065

Unit: rpm

Stall speed	2,400 – 2,700
-------------	---------------

Torque Converter

INFOID:0000000011973066

Unit: mm (in)

Distance "A" between the converter housing and torque converter	14.0 (0.55)
---	-------------

Heater Thermostat

INFOID:0000000011973067

Standard

Valve lift	More than 5.0 mm (0.197 in)
------------	-----------------------------

Reference value

Valve opening temperature	71°C (160°F)
Minimum valve lift	5.0 mm/85°C (0.197 in/203°F)